

# Operation and Instructions

FOR THE USE OF YOUR

## SCA WOLFF SYSTEM

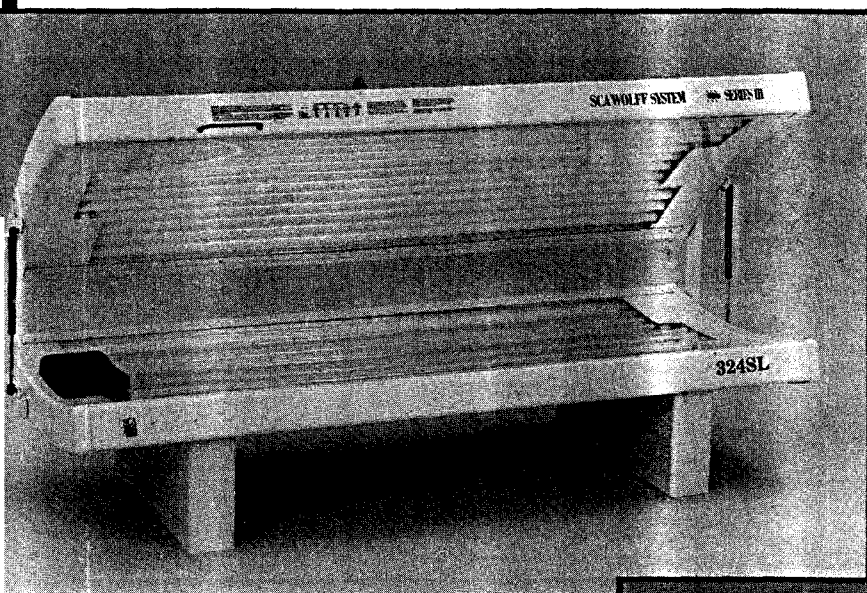

SERIES III  
**324 SL**  
and  
**316 SL**  
INDOOR  
TANNING  
SYSTEMS

SUN INDUSTRIES, INC.  
P.O. Box 2026  
Jonesboro, AR 72402  
1-800-643-0086

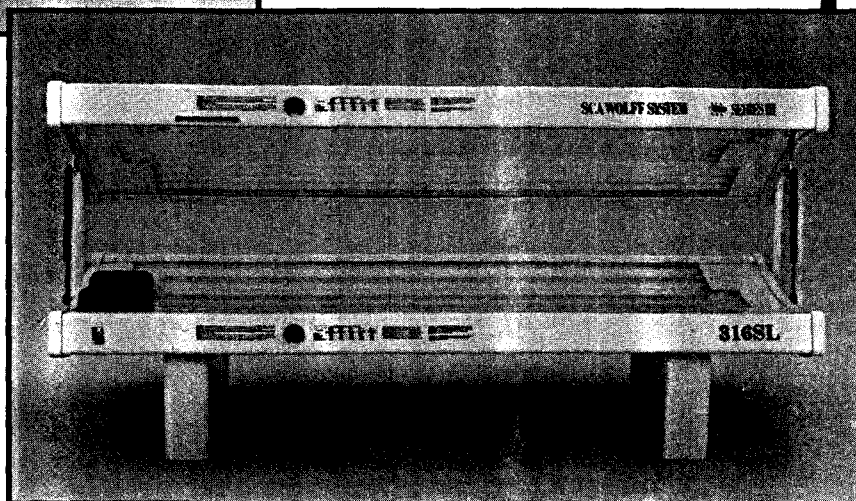

# Mandatory Reading

---

Always read and follow all instructions for proper usage prior to using any tanning system.

## **Remember:**

1. Follow the exposure schedule in accordance with your skin type. Failure to do so may result in overexposure.
2. A tanning system is not a toy. You cannot vary the strength of the lamps in your unit.

Should you have any questions regarding the proper use of your tanning system, contact Sun Industries at:

**1-800-643-0086**  
**8:00 a.m. to 5:00 p.m. (CST)**

Thank you for your cooperation.

# Specifications

## 324 SL

**LENGTH:** 87"  
**SHIPPING WEIGHT:** 500 LBS.  
**WIDTH:** 35"  
**NO. OF LAMPS:** 24  
**HEIGHT:** 29 1/2" - 54"  
**ELECTRICAL:** 120/208 VOLT, 1 $\phi$ , 20 amp  
 120/240 VOLT, 1 $\phi$ , 20 amp  
 120 VOLT, 1 $\phi$ , 30 amp

## 316 SL

**LENGTH:** 87"  
**SHIPPING WEIGHT:** 350 LBS.  
**WIDTH:** 35"  
**NO. OF LAMPS:** 16  
**HEIGHT:** 29 1/2" - 54"  
**ELECTRICAL:** 120 VOLT, 1 $\phi$ , 16 amp

**DANGER — ULTRAVIOLET RADIATION.** FOLLOW INSTRUCTIONS. AVOID OVEREXPOSURE. AS WITH NATURAL SUNLIGHT, OVEREXPOSURE CAN CAUSE EYE AND SKIN INJURY AND ALLERGIC REACTIONS. REPEATED EXPOSURE MAY CAUSE PREMATURE AGING OF THE SKIN AND SKIN CANCER. **WEAR PROTECTIVE EYEWEAR; FAILURE TO MAY RESULT IN SEVERE BURNS OR LONG-TERM INJURY TO THE EYES.**

MEDICATIONS OR COSMETICS MAY INCREASE YOUR SENSITIVITY TO THE ULTRAVIOLET RADIATION. CONSULT PHYSICIAN BEFORE USING SUNLAMP IF YOU ARE USING MEDICATIONS OR HAVE A HISTORY OF SKIN PROBLEMS OR BELIEVE YOURSELF ESPECIALLY SENSITIVE TO SUNLIGHT. IF YOU DO NOT TAN IN THE SUN, YOU ARE UNLIKELY TO TAN FROM THE USE OF THIS PRODUCT.

THIS UNIT UTILIZES UVA LAMPS. REPLACE ONLY WITH **BELLARIUM S SA1-10-100W.**

LIE ON ACRYLIC SURFACE AND LOWER TOP SECTION. TOP SECTION WILL STOP AT 12 INCHES (305 MM) FROM BOTTOM ACRYLIC SURFACE. THE USE OF ANY OTHER POSITION MAY RESULT IN OVEREXPOSURE.

RECOMMENDED EXPOSURE SCHEDULE					
SKIN TYPE	WEEK 1	WEEK 2	WEEK 3	WEEK 4	WEEKLY
	1ST-3RD TREATMENTS	4TH-6TH TREATMENTS	7TH-10TH TREATMENTS	11TH-15TH TREATMENTS	SUBSEQUENT TREATMENTS
II - FAIR	3 MIN.	7 MIN.	15 MIN.	20 MIN.	20 MIN.
III - AVERAGE	3 MIN.	7 MIN.	15 MIN.	20 MIN.	20 MIN.
IV - BROWN	3 MIN.	10 MIN.	15 MIN.	20 MIN.	20 MIN.
V - DARK BROWN	3 MIN.	10 MIN.	15 MIN.	20 MIN.	20 MIN.

**MAXIMUM EXPOSURE TIME IS 20 MINUTES.**

TANNING CAN BEGIN ON A REGULAR BASIS. AN APPEARANCE OF TANNING NORMALLY APPEARS AFTER A FEW EXPOSURES AND MAXIMIZES AFTER FOUR (4) WEEKS OF EXPOSURE FOLLOWING THE RECOMMENDED SCHEDULE FOR YOUR SKIN TYPE.

USE PROTECTIVE EYEWEAR, SUPER SUNNIES, WHENEVER THE EQUIPMENT IS ENERGIZED. READ THE INSTRUCTION BOOKLET BEFORE USING THIS UNIT.

**INSTRUCTIONS ACCOMPANYING THIS PRODUCT SHOULD ALWAYS BE FOLLOWED TO AVOID OR MINIMIZE POTENTIAL INJURY.**

# Warnings and Cautions

---

Certain drugs — particularly those designed to produce photosensitivity — may cause individuals under the influence of this type drug to experience adverse effects and those people should avoid exposure to UV sources of all kinds. Doctors will advise persons taking these drugs of possible adverse effects.

It is recommended that only one person at a time should use the tanning system while in use, and advises using protective eye-wear while taking a tanning session. One pair of goggles is provided with each sunbed sold.

## WARNING

If you have been diagnosed by a physician as being allergic to the sun or are currently taking photosensitive medications,

consult your physician before using the tanning unit.

Occasionally, persons using the tanning system will experience a slight reddening of the skin — usually in small patches — after the second or third session. This redness is often accompanied by an itching sensation. This is nothing more than a heat “rash” caused by heat from the lamps within the system. It is generally very limited and

caused by constant contact of the skin with the acrylic surface. It will go away within approximately 24 hours and should not re-appear. This rashing can be lessened or prevented by turning over occasionally during sessions on tanning unit, and by applying moisturizer lotion to the affected area after the tanning session is completed.

## CAUTION

While there is no immediate clinical evidence regarding UVA exposure and its effects upon **expectant mothers**, it is

strongly advised that expectant mothers be discouraged from using the tanning unit.

# Care and Cleaning of Your Tanning Unit

After each session is completed, spray the acrylic surface with Sundash brand acrylic cleaner, a specially formulated UVT (ultra-violet transmitting) acrylic cleaner. Wipe the surface of the acrylic with a clean cloth. The acrylic should never be wiped with a dry

cloth because this will generate a slight static charge which will attract dust. A mild liquid detergent and water solution can be used temporarily in place of Sundash brand acrylic cleaner.

For maximum efficiency of your tanning unit, periodic cleaning of lamps, reflectors and the inside of the acrylic is required.

**CAUTION:** Do not use excessive amounts of water, any abrasive cleaners, or any spray cleaner that carry label warnings regarding reactions to contact with skin!

**DO NOT USE ALCOHOL.**

## Electrical Safety:

The tanning unit should be disconnected from the power supply before cleaning or disinfecting the inside of the acrylic. Avoid water or solution entering the lamp compartment.

# Relamping Instructions

## MODEL 324 SL AND 316 SL

1. Disconnect unit from power.
2. Remove acrylic from unit by removing screws in front rail and removing acrylic strip. This will expose two slots located toward each end of acrylic rail. Carefully place flat blade screwdriver into slot and gently push down on handle of screwdriver. This will cause acrylic to rise out of channel. Repeat on opposite side.
3. Place left hand in center of acrylic and right hand on front edge of acrylic. Push down with left hand and slide acrylic out with right hand.
4. Push lamp toward foot end of the unit to disengage lamp from stationary lampholder. Remove lamp.
5. Replace by inserting end of lamp into spring loaded lampholder at the foot end of the bed and push until the lamp will insert and properly seat in the stationary lampholder at the head end of the bed.
6. Clean and replace acrylic sheet. (Refer: Care & Cleaning Instructions).
7. Reconnect unit to power.
8. See Care and Cleaning section for information on ordering lamps.

## CAUTION:

Replacement lamps must comply with CFR 21 1040.20.

- A. Replace only with "Bellarium S SA1 10-100W"
- B. When ordering lamps, include model number and serial number.

# Exposure Times and Frequencies

**Melanin** — The brownish pigment produced by special cells in the base layer of your skin determines the individual's tan. As the skin is exposed to the ultraviolet light, the melanin is activated and combines with protein cells that rise to the skin's surface, thus producing a tan.

The amount of melanin in your body determines how quickly and dark you tan. The more melanin produced and exposure time an individual has, the faster and deeper the individual will tan.

## NOTE

The tan produced by the tanning unit is a deep, rich "COSMETIC" tan. However, regardless of how dark an individual may tan on this system, it will not provide adequate protection against overexposure to natural sunlight or UVB tanning systems.

**SKIN TYPE II** - This is the individual that usually burns easily and severely, tans minimally or lightly and peels.

**SKIN TYPE IV** - This individual burns minimally, tans easily and above average with each exposure.

**SKIN TYPE III** - Often referred to as "AVERAGE" complexion, burns moderately and tans about average.

**SKIN TYPE V** - This individual's system rarely burns, tans easily and substantially.

RECOMMENDED EXPOSURE SCHEDULE					
SKIN TYPE	WEEK 1 1ST-3RD TREATMENTS	WEEK 2 4TH-6TH TREATMENTS	WEEK 3 7TH-10TH TREATMENTS	WEEK 4 11TH-15TH TREATMENTS	WEEKLY SUBSEQUENT TREATMENTS
II - FAIR	3 MIN.	7 MIN.	15 MIN.	20 MIN.	20 MIN.
III - AVERAGE	3 MIN.	7 MIN.	15 MIN.	20 MIN.	20 MIN.
IV - BROWN	3 MIN.	10 MIN.	15 MIN.	20 MIN.	20 MIN.
V - DARK BROWN	3 MIN.	10 MIN.	15 MIN.	20 MIN.	20 MIN.

No two individual skin tones are the same. A tan to one person may be different to another and treatment length may vary.

**MAXIMUM EXPOSURE TIME IS 20 MINUTES.**

## NOTE

Since the back and stomach areas of the body will receive the majority of the tanning rays, it is recommended that individuals spend at least five (5) minutes lying on each side of the body during sessions to achieve a full-bodied tan.

Since your tanning unit will cast off some heat, it is recommended that a small fan be used to improve air circulation during sessions. Likewise, adequate **ventilation** of the room or booth housing the tanning units is required for comfortable operation.

It is recommended that you do not use any creams, oils or lotions, (particularly

suntan lotions) that are not recommended by Sun Industries, Inc. Equally important — many facial makeups have oil bases and should be removed prior to a session. It is recommended that, following a tanning session, a skin moisturizer be applied. This promotes a smoother, more even looking tan.

# Assembly Instructions

## Required for proper assembly:

- A. Minimum 2 adults
- B. Philips head screwdriver
- C. 1/2 inch shallow well socket
- D. 9/16 inch shallow well socket
- E. 3/8 inch drive ratchet
- F. Open area, free from obstructions

**NOTE:** Allow a slight degree of flexibility when attaching brackets. Brackets must be slightly movable to perform Step 4.

**NOTE:** Assemble bottom unit first.

## Step 1: Assembly Preparation

Carefully remove bottom unit from carton and place upside down on floor - metal side facing up. Remove legs and parts package from carton.

**NOTE:** On some units legs may already be attached to unit.

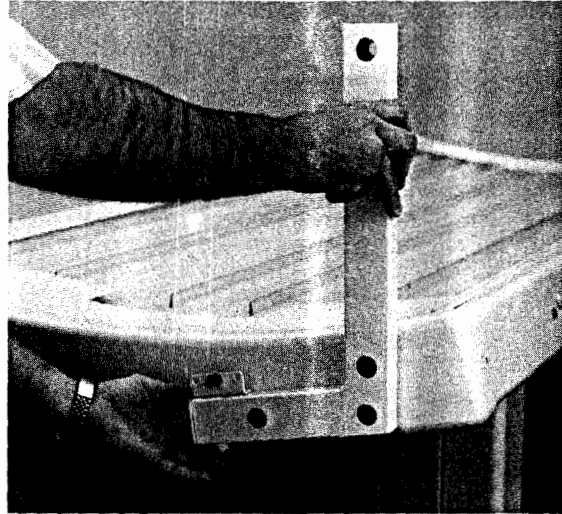

## Step 2: Leg Installation: ( Photograph A)

Place legs into position and align with holes on bottom of unit. Place one, 1/4" 20 x 1" thru head bolt, into each hole and hand tighten. When all 4 bolts are in position, tighten securely with philips head screwdriver.

When legs are securely fastened, return unit to up-right position.

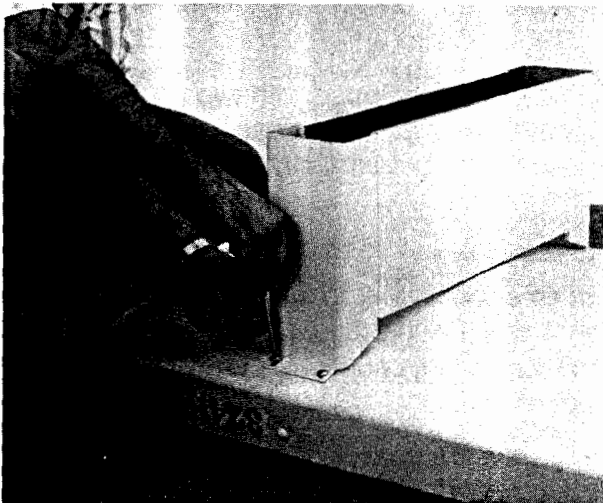

**Photograph A**

## Step 3: Support Bracket Installation: Photographs B and C.

Place support brackets on outside of bottom unit lining holes up over studs. Fasten nuts to studs using 1/2 inch shallow well socket.

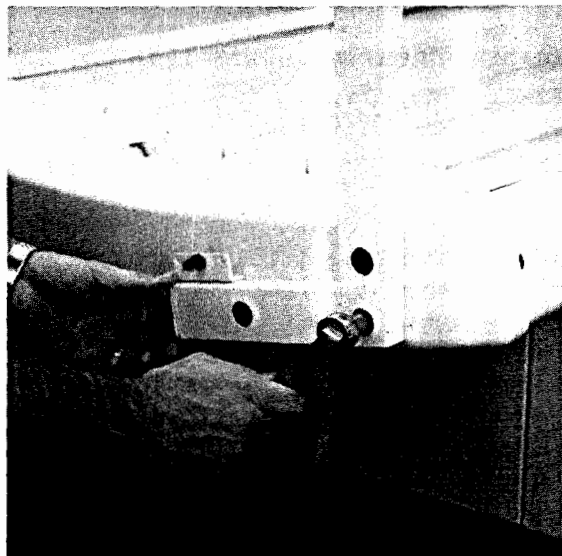

**Photograph C**

## Step 4: Canopy Installation: Photograph D.

**IMPORTANT:** Prior to installing canopy, brass bushings must be in place. Brass bushings slide over studs that protrude from sides of canopy.

Using additional adult assistance to lift canopy, place canopy into position between support brackets and align studs through holes in top part of bracket. Once canopy is aligned secure nuts onto studs using 9/16 inch shallow well socket.

Now fasten bottom 3 nuts firmly to unit.



# Assembly Instructions

**IMPORTANT:** Continue to hold canopy in position during this procedure. Canopy will not be supported until cylinder installation has been completed.



Photograph D

## Step 5: Cylinder Installation: Photographs E and F.

Check safety clips for proper alignment. When properly aligned, cylinder head will snap easily onto ball stud.

**NOTE:** Attach cylinders to ball studs on bottom unit first, then raise canopy to align top. Wide end of cylinder is always up.

After cylinders are attached, raise and lower canopy several times and check connections.

All connections must be firmly secured prior to any usage.

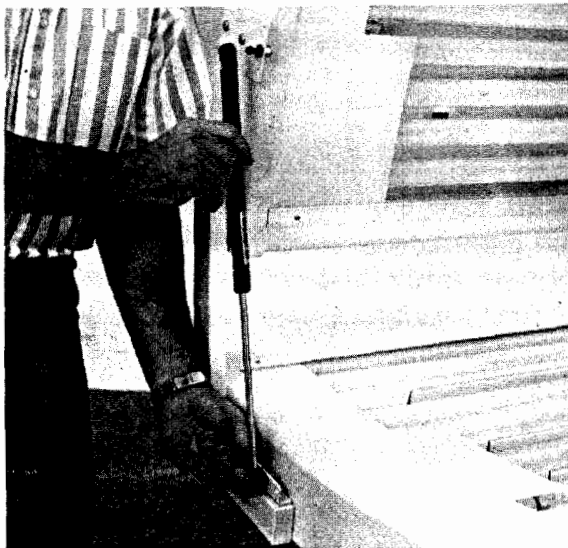

Photograph E

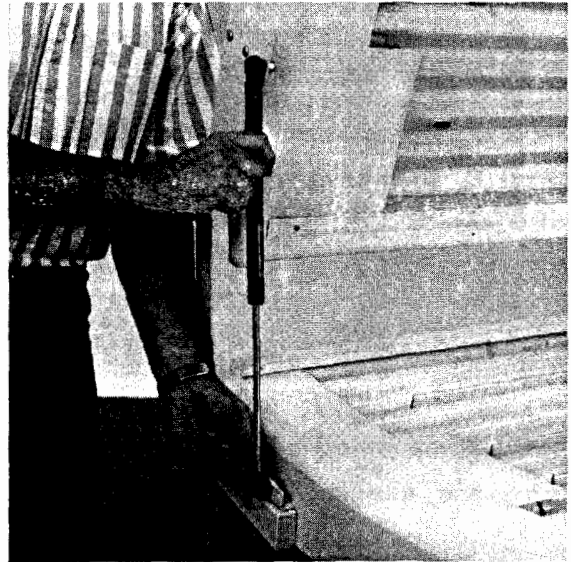

Photograph F

## Step 6: Top unit power connection:

Align three (3) conductor plug from top unit with receptacle in bottom unit that is labeled "top unit". Insert and twist clockwise until locked.

## OPERATING INSTRUCTIONS 316 SL ONLY

The 316 SL is equipped with two (2) 20 minute timers. One located on the top unit and one located on the bottom unit.

### To Set Time

Turn timer clockwise on each timer and set time in accordance with your exposure schedule. Time will automatically count down and shut off unit at sessions end.

### To Stop Unit

Turn timers counter clockwise, back to zero or press emergency on/off switch.

Should you have any questions regarding assembly process please contact our service department at 1-800-445-0624.



# Intellitan Single Station Remote

For **R-32B, R-26B and 324 SL ONLY**

## Operating/Programming Instructions

**NOTE:** UP =   
DOWN = 

The INTELLITAN Single Station Remote Timer is equipped with 20 feet of extension cable. Simply plug timer into the back of the unit, (Timer is powered by tanning unit). Timer will display **00:00**.

### VERY IMPORTANT NOTE

The INTELLITAN REMOTE is designed to operate primarily with the **SUNDASH GOLD** series R-26B, R-32B and the 324 SL.

If you are attempting to use the INTELLITAN REMOTE with a **PLATINUM SERIES** unit, you must follow the programming instructions for the **INTELLITAN CONSOLE!**

**Remember:** INTELLITAN REMOTE has the 20 foot cord and plugs into the back of the bed.

INTELLITAN CONSOLE has the 6 foot cord and plugs into a 110 volt outlet.

### To Set Time

STEP 1: Press **UP** button to reach desired setting, in minutes.

STEP 2: Press **Start/Stop** button to begin operation. Session is counted down in minutes and seconds.

**NOTE:** If **Session Delay** has not been pre-programmed, tanning unit will immediately light. If **Session Delay** has been pre-programmed, unit will light in accordance with delay.

### To Stop Unit

STEP 1: Press **Start/Stop** button at any time during session. Lamps will shut off and countdown will **hold time**.

STEP 2: To **STOP** unit during **Session Delay** countdown, press **Start/Stop** button **TWICE**.

**NOTE:** (Use Emergency "ON/OFF" switch only when necessary)

### To Restart Unit

STEP 1: Press the **Start/Stop** button **ONCE**. Unit will light and countdown will resume.

STEP 2: If **Session Delay** has been pre-programmed, press **Start/Stop** button **TWICE** to restart.

### To Clear Time

STEP 1: Press reset button, timer clears to read **00:00**.

**NOTE:** If unit is counting down, **Start/Stop** button must be pressed prior to resetting.

### To Set Time/Operate Unit Utilizing Session Delay

• SEE "TO PROGRAM FEATURES, GO TO PARAMETER 5, P:05, AND PROGRAM)

1. Press **UP** button to reach desired setting in minutes.
2. Press **Start/Stop** button, display will now **FLASH**, indicating **Session Delay** has begun.
3. Display will continue to **FLASH** as **Session Delay** counts down. Countdown time is not visually displayed.
4. At **one (1) minute** prior to bed lighting, an audible beep will sound. Another will sound at **30 seconds**. At **15 seconds** the beep will sound and continue once **each second** until unit lights.
5. You can override the **Session Delay** at any time during countdown by pressing the **Start/Stop** button **ONCE**.

**NOTE:** You **CANNOT** override the session delay via the emergency on/off switch on the tanning unit.

### To Program Features - Enter Password Clearance:

Press **UP** and **DOWN** button at same time and hold in for one second. Display will read **0000**. Now press **Reset** button. **0000** will now flash. Now press **UP** button, hold in, scrolling up to **0010**. Now press **Reset** button. You have now reached **PROGRAM 1**. Display will read **0001**. You can now display and edit functions.

# Intellitan Single Station Remote

## For R-32B, R-26B and 324 SL ONLY

### Operating/Programming Instructions cont.

#### **IMPORTANT NOTE:**

Proceed slowly through viewing and editing of various parameters.

You **CANNOT** view parameters in reverse order. That is, you **CANNOT** go from **PARAMETER 7** to **PARAMETER 6**.

If you proceed too quickly or inadvertently pass by the parameter you wish to view/edit, you must exit the system, (Press **Start/Stop** button until you reach **00:00**) Then re-enter password clearance to get back into system.

Now press **Start/Stop** button to reach **Parameter 2, (P:02)**, the **Alarm Enable/Disable** function.

This is the chime mechanism that provides an audible "beep" sound to indicate the various operations occurring. You have the option to use the audible beep or silence it.

**NOTE:** The unit comes with the chime mechanism activated to provide an audible beep. To maintain the mechanism, press the **Start/Stop** button now and proceed to **P:03**. If you wish to silence it, do the following:

Press **Reset** button then release it. Display will register **0001** and will flash. Press the **Down** button and hold it in scrolling down to **0000**. Now press **Reset**. Chime is now deactivated.

Now press the **Start/Stop** button to reach **Parameter 3, (P:03)**, the **Station Address** function.

This function allows you to identify the unit for interface with the CCS-1, the 1-10 unit console timer. Press the **Reset** button and release it. Display will flash **0001**, indicating Unit #1. To identify the unit and assign a cod number to it other than "1", press the **UP** button and scroll to a higher number. Once you reach the desired number, release the **UP** button. Now press the **Reset** button and release it. The unit has now been designated accordingly.

Now press the **Start/Stop** button to reach **Parameter 4, (P:04)**, the **Lamp-Hour Accumulation on Current Lamp Bank** function.

Lamp hour accumulation is immediately displayed from **0000** to **1000**. When current lamp hour accumulation reaches **1000**, **3 beeps** will chime each time the unit is turned on, indicating that a lamp change is necessary. Chime will not sound if it has been deactivated through **P:02**.

Upon changing lamps, to clear counter to zero, press **Reset** button and release. Display will flash. Now press and continue to hold the **DOWN** button and scroll display back to **0000**. Press reset button and release. Accumulation is cleared.

• Now press the **Start/Stop** button to reach **Parameter 5, (P:05)**, the **Session Delay, Prep-Time Monitor** function.

To adjust session delay from 0-5 minutes, press **Reset** button then release it. Now press either the **UP** or **DOWN** button to reach desired setting and release buttons. Time is displayed from **0000** to **0050**. Numbers equal tenths of a minute.

For example: **0025** equals 2 minutes, 30 seconds. ( $25 \times 6 \text{ seconds} = 150 \text{ seconds}$ ). Press **Reset** button and release it.

**NOTE:** Session delay cannot be overridden via the Emergency ON/OFF switch.

Now press the **Start/Stop** button and release it to reach **Parameter 6, (P:06)**, **The Session Counter**. Immediate display of total number of times the unit has been turned **ON/OFF** since first day of operation. Counts from **0000** to **9999** then rolls over. This function cannot be reset.

Now press **Start/Stop** button to reach **Parameter 7, (P:07)**, **Remote Enable/Disable** function.

Display should immediately read **0000**, indicating that the system is in the remote mode. **DO NOT ADJUST**.

**NOTE:** This function is only utilized when working in conjunction with the **CCS-1**.

Now press **Start/Stop** button to reach **Parameter 8, (P:08)**, **Total Hour Accumulation**. Immediate display of total hours on unit since first day of operation. Counts from **0000** to **9999**, then rolls over. This function cannot be reset.

Now press **Start/Stop** button to exit program mode.

#### **IMPORTANT NOTE:**

**INTELLITAN SINGLE STATION REMOTE TIMER SHOULD BE MOUNTED IN A LOCATION THAT IS IN ACCORDANCE WITH ALL REGULATIONS GOVERNING REMOTE TIMER ACCESS AND CONTROL.**

# WIRING DIAGRAM

316 SL  
BOTTOM

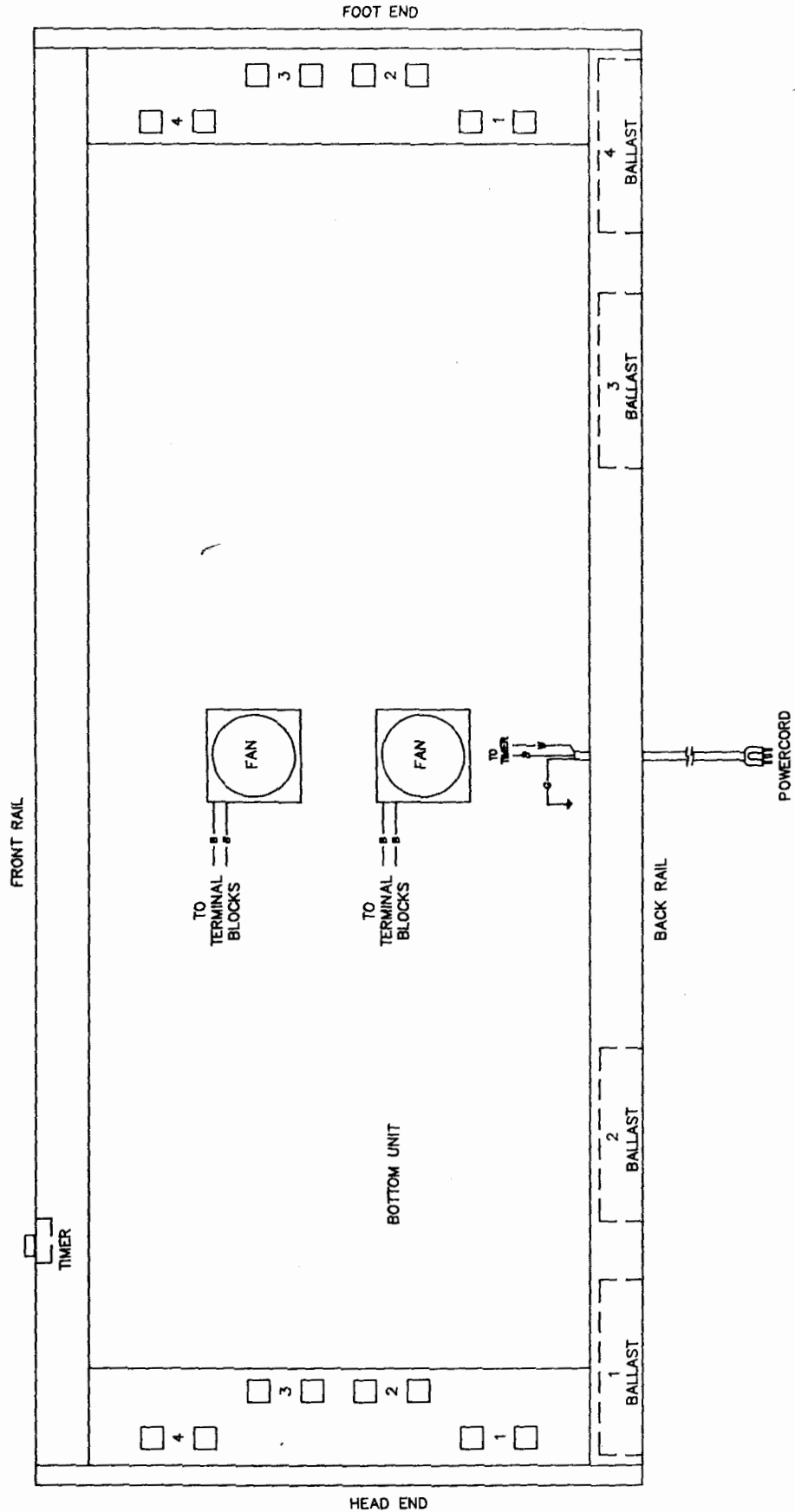

# WIRING DIAGRAM

316 SL  
TOP

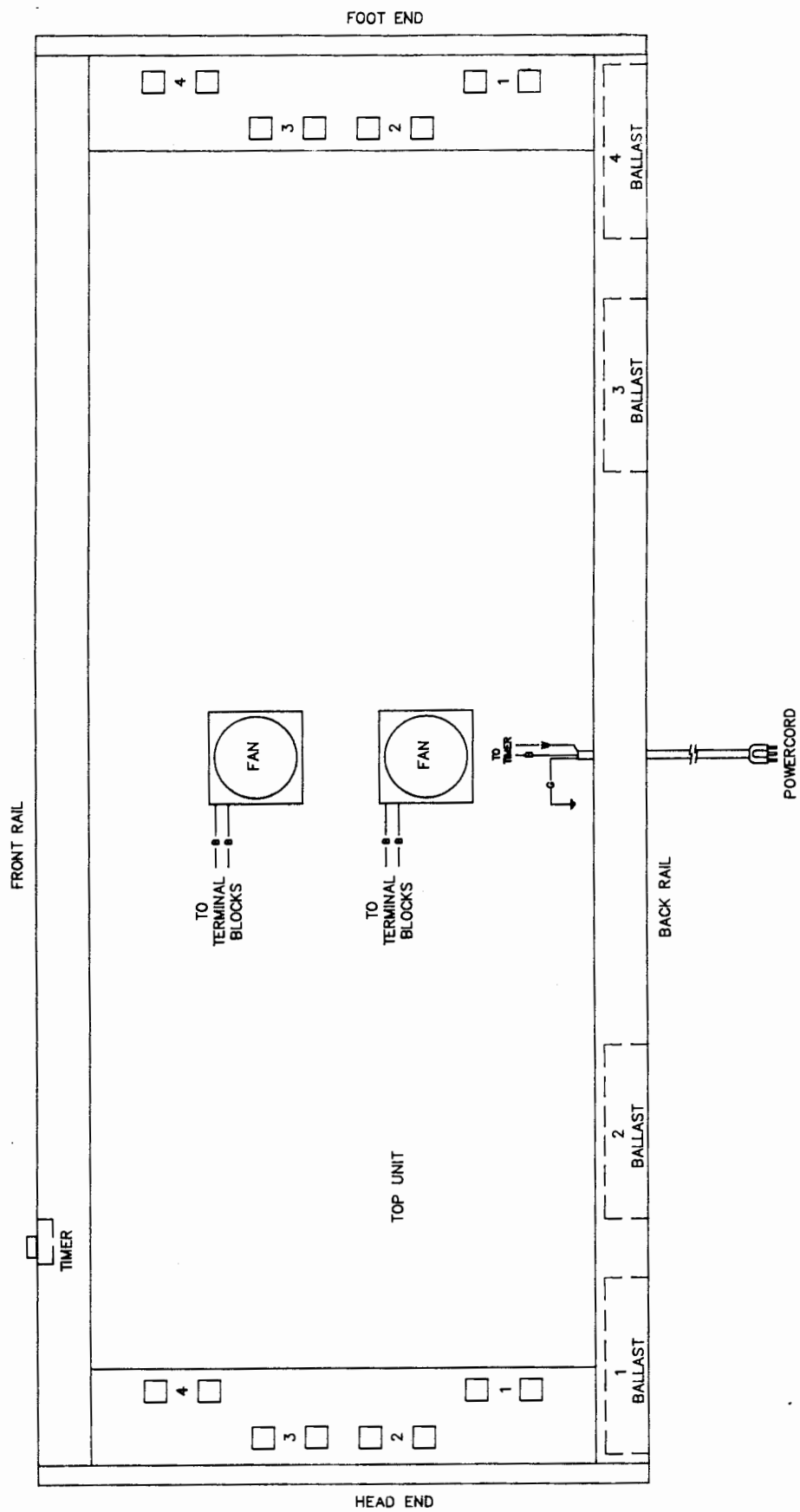

# WIRING DIAGRAM

**324 SL  
BOTTOM**

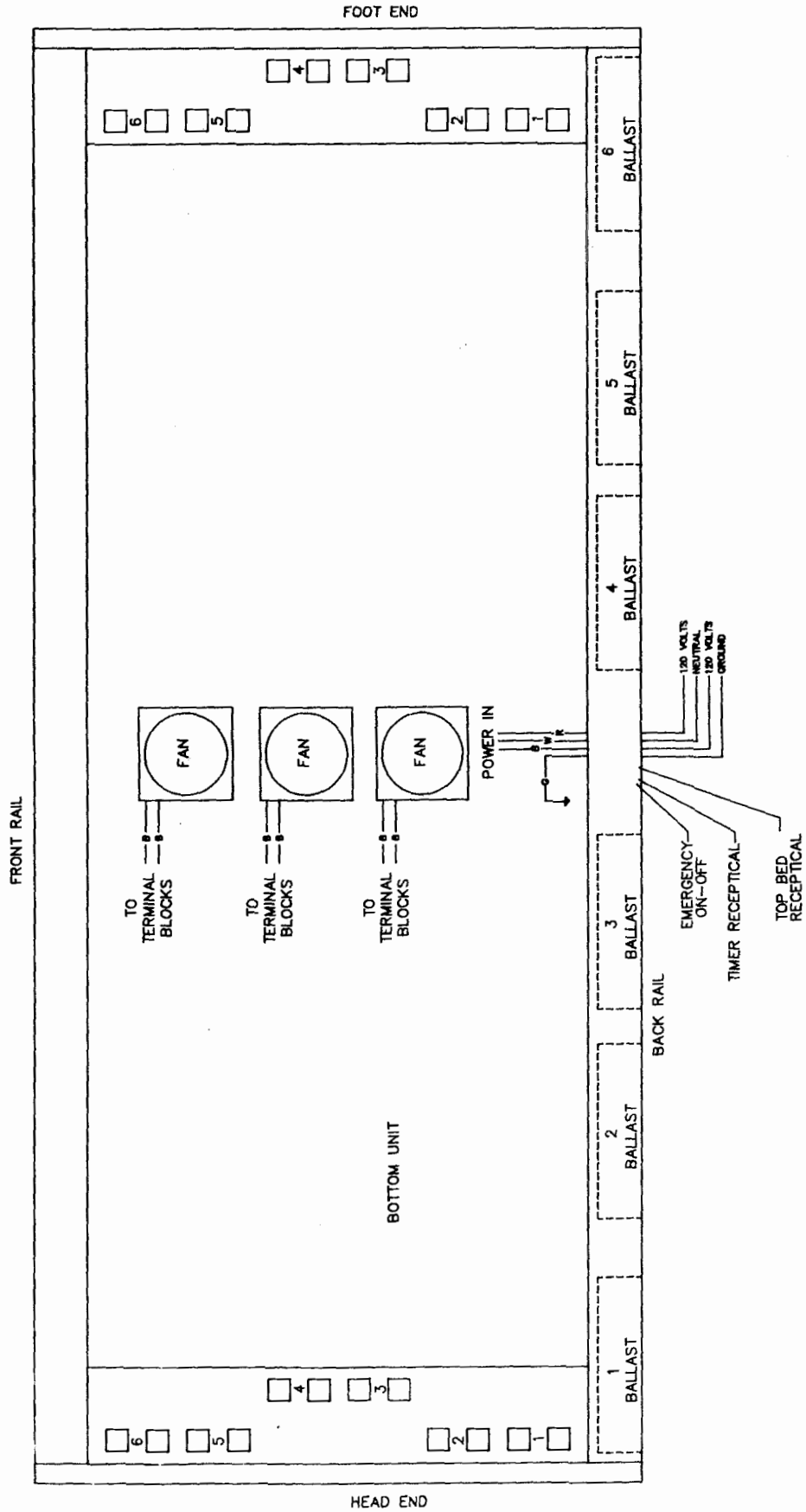

# WIRING DIAGRAM

324 SL  
TOP

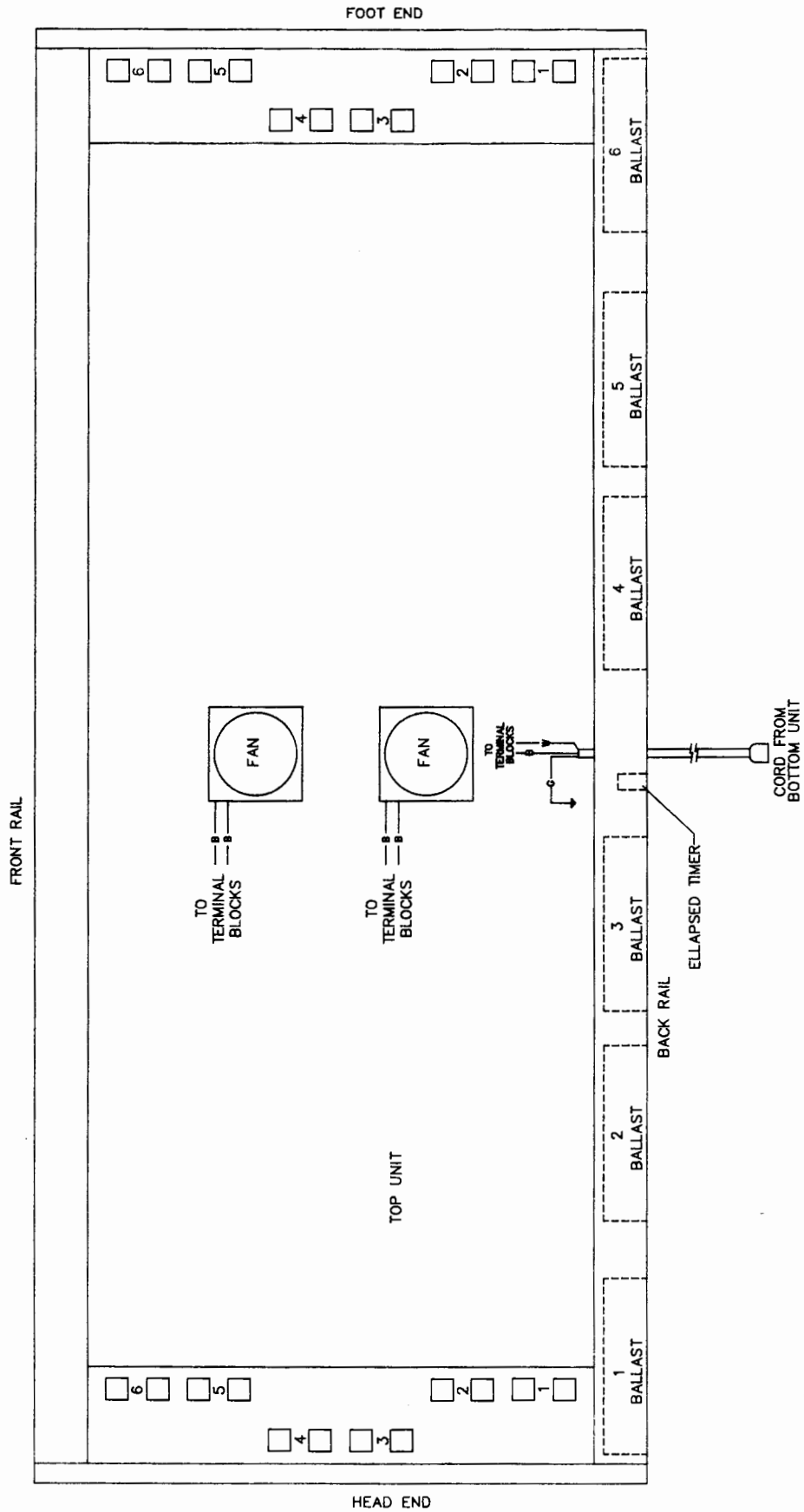

# WIRING DIAGRAM

316 SL & 324 SL

TYPICAL TIMER DIAGRAM

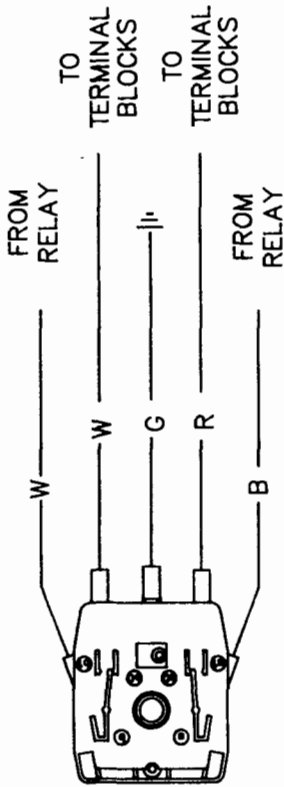

TYPICAL BALLAST DIAGRAM

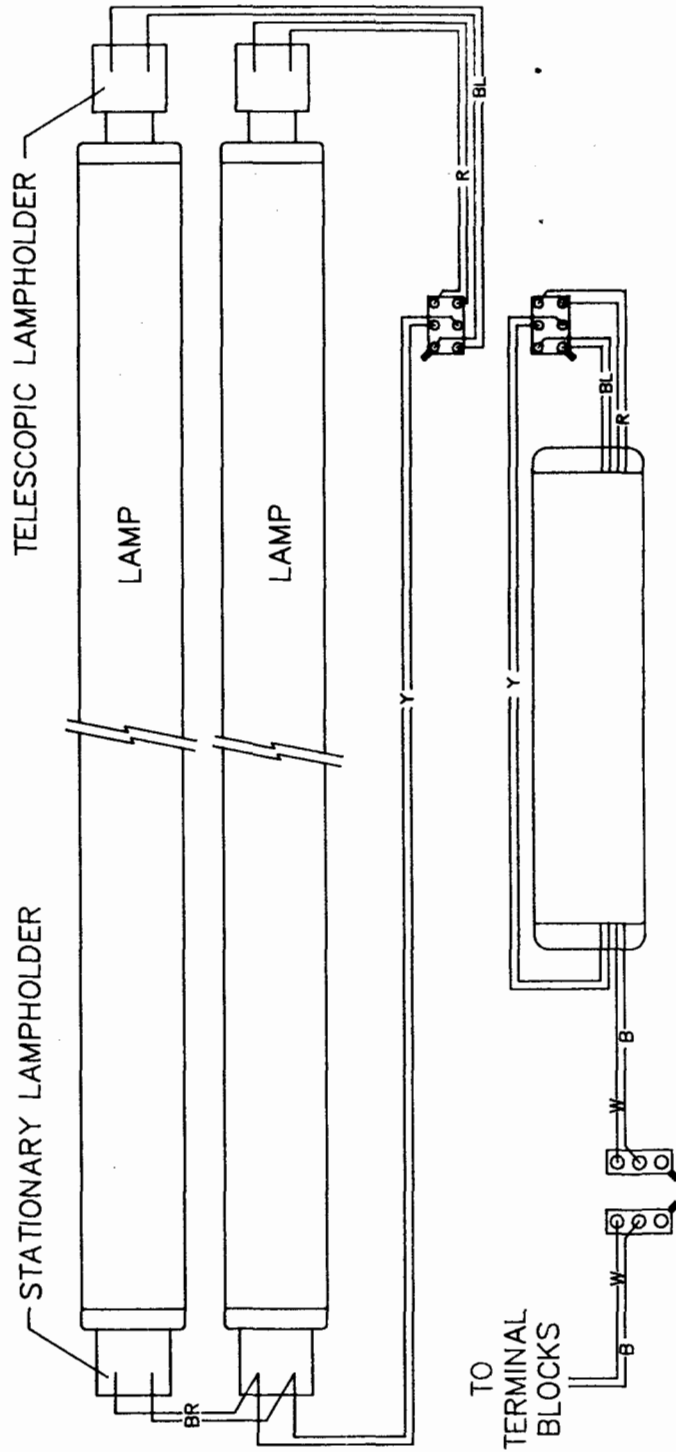



# WIRING DIAGRAM

324 SL

## TOP UNIT DETAIL

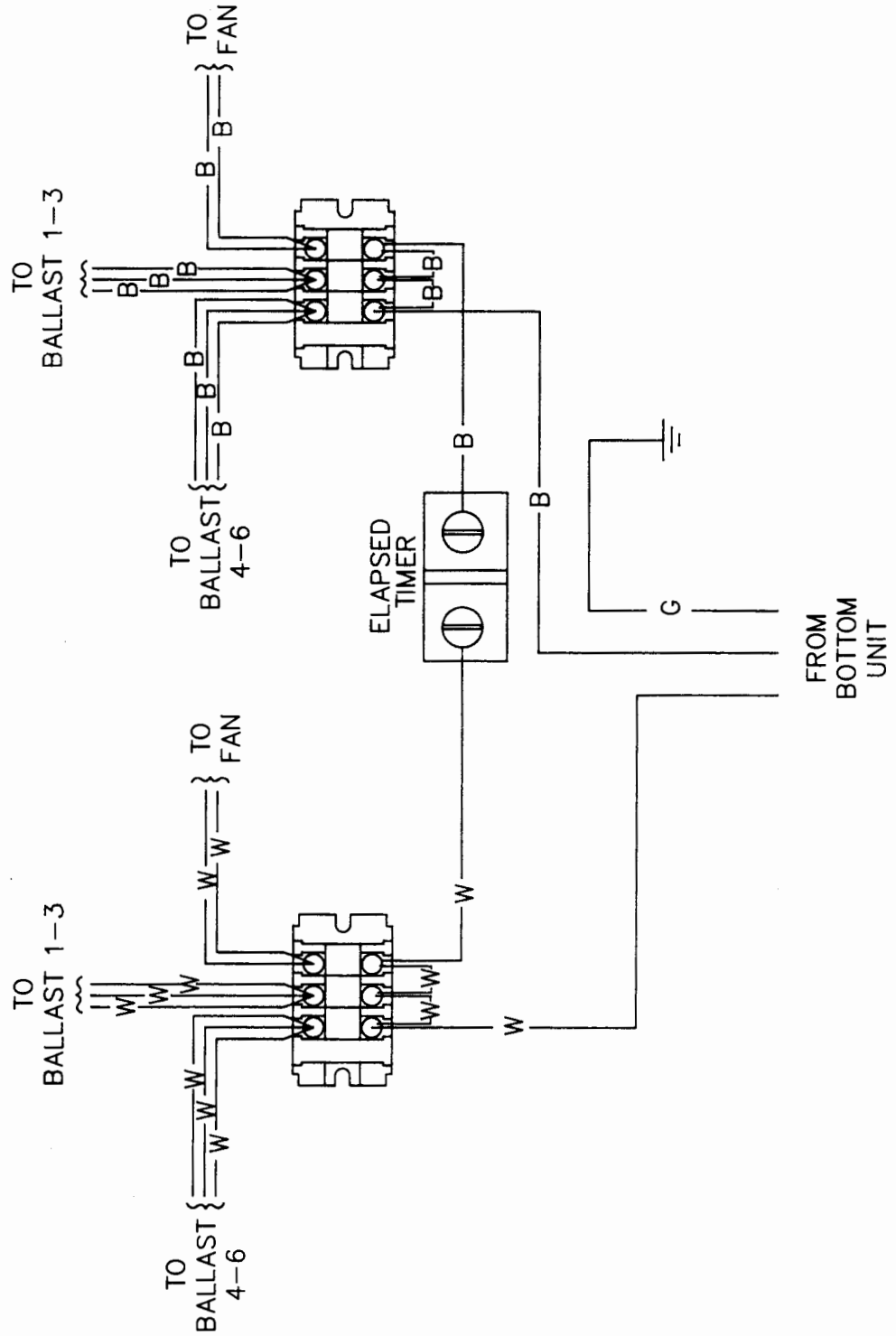

# WIRING DIAGRAM

324 SL

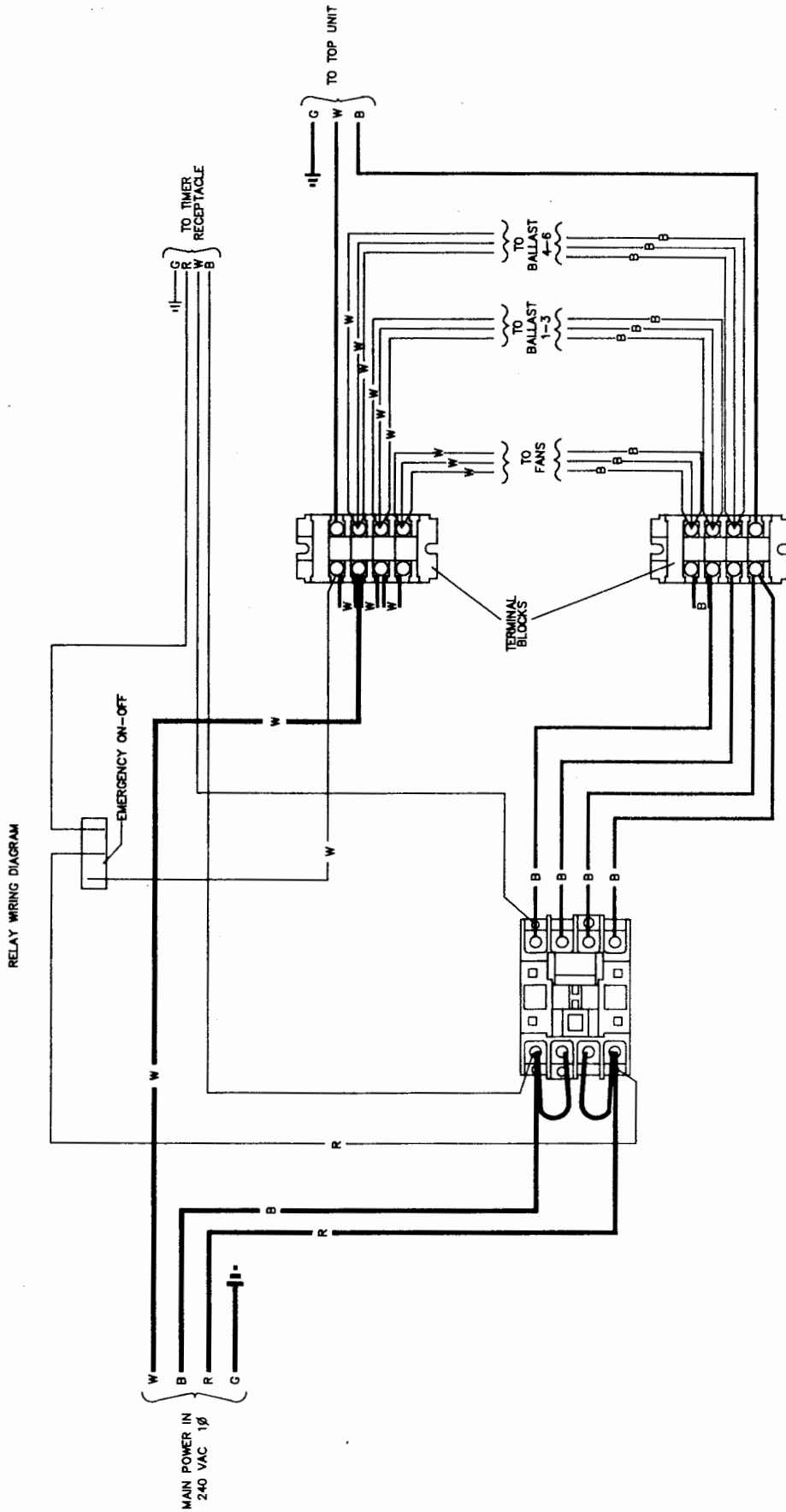

# General Troubleshooting

## 324 SL

## Guide

## 324 SL

The following troubleshooting information is divided into two sections. Section A contains items in which the owner may check without the aid of a service person. Section B contains items which must be performed by **QUALIFIED SERVICE PERSONNEL ONLY**. If you have any questions other than the ones listed in your troubleshooting guide, contact your dealer or distributor.

**(NOTE: All tanning units are not the same, therefore some of the causes may not apply to your unit.)**

### General Troubleshooting (Section A)

#### 1. Tanning unit does not operate.

##### CAUSE

1. No power to unit.
2. Timer is not activated.

##### SOLUTION

1. Check circuit breaker servicing bed.
2. Press up button, then start button.

**(NOTE: If there is power to the unit but the display on the timer is not lighting, you may need to replace the power board and/or the C.P.U. board. Contact Sun Industries or your local representative for information.)**

#### 2. Lamps won't light or lamps flicker.

##### CAUSE

1. Lamp not seated properly in lampholder.
2. Faulty lamp.

##### SOLUTION

1. Remove lamp, inspect contacts on lamp, and reinstall lamp securely into lampholder.
2. Replace lamp. (Refer to Instruction Manual for correct lamp).

#### 3. Top unit does not hold its position.

##### CAUSE

1. Cylinder(s) wearing out.

##### SOLUTION

1. Replace cylinder(s).

## 324 SL General Troubleshooting (Section B) 316 SL

All services in the following section are to be completed by a Qualified Service Technician. This section is to aid in isolating and correcting any problems which may occur and is not intended for use by the owner. Refer to the assembly instructions included with each unit for reference in disassembling and wiring the tanning unit. Disconnect all power to the unit before servicing. Use only factory authorized components for replacement parts.

#### 1. Tanning unit does not operate.

##### CAUSE

1. Incorrect connection of incoming power.
2. Faulty timer.
3. Faulty relay in bed.
4. Poor wiring connections.

##### SOLUTION

1. Check electrical connections on wiring diagram and correct as necessary.
2. Replace.
3. Replace.
4. Check wiring circuit against appropriate wiring diagram and correct as required.

#### 2. Lamps won't light.

##### CAUSE

1. Poor wiring crimp at lampholder.
2. Faulty or damaged lampholder.
3. Incoming power to unit incorrect.
4. Faulty ballasts.
5. Loose power wire to ballasts.

##### SOLUTION

1. Check for loose wire and repair.
2. Replace.
3. Check incoming voltage and correct to requirements.
4. Locate and replace.
5. Locate loose wire and repair.

# IMPORTANT NOTE

---

## **PREVENTIVE MAINTENANCE SCHEDULE**

Your SUNDASH Tanning System consists of many movable parts that may require periodic adjustments and/or replacement.

It is imperative that you, the owner and/or operator, check all components for any signs of wear which may occur through normal use.

The frequency of your preventive maintenance schedule should be determined according to equipment usage. The minimum of a monthly inspection of all components is a good guideline, however, actual frequency and thoroughness of inspections is your responsibility.

Should you require any assistance or need additional information, please call our Service Department at **1-800-445-0624**, Monday through Friday 8:00 a.m.-5:00 p.m. CST.

## **REPAIRS — SERVICE — REPLACEMENT PARTS AND LAMPS — EYE PROTECTION**

If you are in need of any of the above mentioned products or services, you should contact the dealer/distributor through whom you purchased your unit. In the event that you are unable to do so, please call our Service Department for assistance at: **1-800-445-0624**.

**NOTE:** All repairs and replacement components including, but not limited to, protective eyewear, lamps, timers, acrylic and reflectors must be in compliance with CFR 21 1040.20 of the laws regulated by the FDA.

## **ACCESSORY ITEMS**

Contact our Merchandising Department to order all your tanning supplies including SUNDASH lotions, moisturizers, accelerators, shower gels, massage oil, acrylic cleaner and a complete selection of both home and commercial tanning accessories. Call **1-800-235-8555**.

# SUN INDUSTRIES, INC.

## LIMITED WARRANTY

---

Sun Industries, Inc. warrants its products to be free from defects in materials and workmanship under intended normal use as described in the unit's Operation and Instruction Manual, for a period of one (1) year from date of sale.

This Limited Warranty applies only to the original purchaser of the equipment through Sun Industries, Inc. or its authorized dealer or distributor, and is not transferable.

Sun Industries, Inc.'s obligations under this warranty are limited to repair or replacement of any defective part without charge for that part to the original purchaser, with the following exceptions:

- A. Fluorescent lamps are warranted against defects for a period of thirty (30) days from date of sale.
- B. Only parts obtained through Sun Industries, its authorized dealers or distributors may be used. Transportation costs for parts shipped to the consumer and the return of defective parts to Sun Industries are not included.
- C. Labor will be furnished without charge for ninety (90) days from date of purchase only. All labor and related charges must be authorized by Sun Industries prior to start of repairs, and must coincide with Sun Industries, Inc.'s established rates and time allotment policy.
- D. Acrylic: Refer to Manufacturer's Acrylic Warranty Policy.

It is imperative that the original customer completes and returns the enclosed warranty card within 10 days after purchase to insure valid registration and coverage for potential claims.

If the warranty card is not registered, proof of purchase from Sun Industries, Inc. or its authorized dealer or distributor will be required prior to any consideration on warranty claims. This could result in service delays.

This warranty is extended to the individual or legal entity, whose name appears on the warranty registration card filed with Sun Industries, Inc., or whose name appears on the original sale document and may not be transferred to any other individual or legal entity.

This warranty does not apply to any failure of the product, or any parts of the product due to alterations, modifications, misuse, abuse, accident, improper maintenance, improper installation or if the serial number on the product has been removed, altered, or defaced. Adequate packaging must be used for returned goods to prevent freight damage.

**THIS WARRANTY IS EXPRESSLY IN LIEU OF ALL OTHER WARRANTIES, EXPRESSED OR IMPLIED, INCLUDING THE WARRANTIES OF MERCHANTABILITY AND FITNESS. NO PERSON, FIRM OR CORPORATION IS AUTHORIZED TO OBLIGATE SUN INDUSTRIES, INC. FOR ANY LIABILITY IN CONNECTION WITH THE SALE OR USE OF THESE GOODS.**

This warranty gives you specific legal rights, and you may also have other rights which vary from state to state.

# LIMITED ACRYLIC WARRANTY

---

Sun Industries, Inc. warrants its acrylic sheets to be free from defects in material and workmanship, under intended normal use, for a period of one (1) year from date of sale of the tanning bed. Due to the tanning lotions, cosmetics, disinfectants and improper cleaners used on tanning surfaces that cannot be controlled by Sun Industries, Inc., after the first thirty (30) days of warranty period, acrylic will be subject to a prorated cost to the consumer on breakage and crazing.

Sun Industries, Inc.'s obligations do not include transportation charges on replacement acrylic.

Sun Industries, Inc. assumes no liability for the cost of removing defective sheets or installing replacement sheets, nor for damage to persons or property, or indirect, incidental or consequential damages.

To make a claim, contact an authorized dealer or distributor of Sun Industries, Inc. or Sun Industries, Inc. Service Department with the model number, the serial number, and the date of purchase of the bed in which the acrylic will be used.

**THIS WARRANTY IS EXPRESSLY IN LIEU OF ALL OTHER WARRANTIES, EXPRESSED OR IMPLIED, INCLUDING THE WARRANTIES OF MERCHANTABILITY AND FITNESS. NO PERSON, FIRM OR CORPORATION IS AUTHORIZED TO OBLIGATE SUN INDUSTRIES, INC. FOR ANY LIABILITY IN CONNECTION WITH THE SALE OR USE OF THESE GOODS.**

Some states do not allow excluding or limiting incidental or consequential damages, so the above exclusion may not apply to you. This warranty gives you specific legal rights, and you may also have other rights which may vary from state to state.

**Sun Industries, Inc.**  
P.O. Box 2026  
Jonesboro, Arkansas 72402  
**1-800-445-0624**  
**501-935-1130** (in Arkansas)

# WARRANTY CLAIMS POLICIES AND PROCEDURES

## SUN INDUSTRIES, INC. FACTORY DIRECT ACCOUNTS

---

This section on Warranty Claims applies only to units obtained directly through Sun Industries, Inc. or where Warranty Claims must be handled directly through the manufacturer due to mitigating circumstances or where required by law.

### **PLEASE READ CAREFULLY PRIOR TO CALLING!**

To file a Warranty Claim directly through Sun Industries, Inc., the following procedures must be observed.

1. Locate serial number and model number of unit under warranty. This information can be found on the back panel and/or on the leg assembly of the unit.
2. If you have not registered a completed Warranty Card with Sun Industries, Inc., proof of purchase in the form of a paid receipt/invoice, copy of canceled check or credit card statement must be provided before any claim will be considered.
3. Identify and prepare to explain to the best of your ability the problem you are experiencing with the unit.

**NOTE:** Consult the trouble shooting guide located in this manual prior to calling. The majority of problems customers experience are actually just basic misinterpretations of operating instructions.

4. If, after observing points 1 through 3, you still require assistance please call our Service Department at **1-800-445-0624** and notify them of your specific concern.
5. Upon identifying the problem, our Service Department will then institute a course of action designed to return unit to working order.

### **PARTS WARRANTY CLAIMS/CREDIT PROCEDURES**

If it is determined that a defective part needs to be replaced, Sun Industries, Inc. will ship the replacement part to the customer freight collect. The customer will be billed on a net 30 basis for the part only.

At this time, the customer will be issued a return authorization (RAN) number. This number will appear on the invoice that will accompany the replacement part.

The customer will, within 15 days of receipt of new part, then be required to return the defective part to Sun Industries, Inc. The return authorization invoice (R.A.I.) must accompany the defective part in order to receive credit. A credit invoice offsetting the original bill will be issued upon Sun Industries, Inc.'s receipt of defective part and R.A.I.

**NOTE:** Sun Industries, Inc.'s obligations are limited to the replacement part only. Freight must be paid by the customer.



# WARRANTY CLAIMS POLICY & PROCEDURES

---

## 1. When to file a Warranty Claim:

In the event that your tanning system is not functioning properly under intended normal use as described in the unit's Operation and Instruction Manual, you may then have established cause to file a Warranty Claim.

**NOTE:** Both the tanning system and legal registered owner must meet the criteria established under Sun Industries, Inc.'s Limited Warranty as described in this manual before any Warranty Claim will be considered.

## 2. Where to call to place a Warranty Claim:

Sun Industries, Inc. is supported nationwide by an extensive dealer/distributor network through whom the majority of our units are sold. These dealers/distributors are required by contract to stock sufficient parts to meet the various warranty and non-warranty needs of their customers.

Therefore, in order for you to properly file a Warranty Claim, you must locate the name and phone number of the dealer/distributor through whom you purchased your unit. Normally this information can be easily located either on your paid invoice or other proof of purchase documentation that you received when taking delivery of the unit.

Next, notify the dealer/distributor of the serial number, model number and date unit was purchased. This will initiate the Warranty Claim process.

Upon determination of the problem, your dealer/distributor can then supply you with the part(s) and proper instructions to return your unit to working order.

Each dealer/distributor has their own internal procedure for handling Warranty Claims and credits.

**NOTE:** Sun Industries, Inc., the manufacturer, does not involve itself in the direct handling of a Warranty Claim except where mitigating circumstances apply and where required by law.

# PARTS WARRANTY CLAIM/ CREDIT REVIEW

---

1. Customer calls Sun Industries, Inc. and notifies the Service Department of problem.
2. Sun Industries, Inc.'s Service Department determines course of action.
3. Sun Industries, Inc. ships part and R.A.I. to customer freight collect and bills customer on net 30 basis for part only.
4. Customer, within 15 days of receiving new part, returns defective part to Sun Industries, Inc. along with R.A.I.
5. Upon receipt of defective part and R.A.I., Sun Industries, Inc. issues customer a credit invoice which offsets original bill. Customer's account is returned to zero balance concerning this claim.

**NOTE:** If part returned to Sun Industries, Inc. proves to be operational and not defective, or if product code numbers on part do not correspond with individual unit data on file with Sun Industries, Inc., then a 30% restocking fee will be charged in addition to the retail purchase price of part.

Acknowledgement of this Agreement is not required for acceptance of the foregoing stipulations.

## **LABOR WARRANTY CLAIM/CREDITS PROCEDURES**

Sun Industries, Inc. furnishes labor without charge for a period of 90 days from date of purchase. All labor and related charges must be authorized by Sun Industries, Inc. **prior** to start of repairs, and must coincide with Sun Industries, Inc.'s established rates and time allotment policy.

Please contact our Service Department for authorization and billing procedures.

# Limited 5 Year Warranty

---

Sun Industries, Inc. warrants specific individual components of the R-26B, R-32B, 316SL and 324SL tanning systems against defects in materials and workmanship for a period of 5 years from date of purchase. Coverage is limited to units purchased after January 1, 1992.

This warranty is restricted to the following components only:

R-26B, R-32B

Back Panels  
End Caps  
Leg Assembly  
Reflectors  
Lamp Chassis  
Structural Steel Backbone  
Aluminum Rails, Front & Back

316SL, 324SL

Back Panels  
End Caps  
Leg Assembly  
Reflectors  
Lamp Chassis  
Structural Steel Backbone  
Aluminum Rails, Front & Back

**NOTE:** Components are warranted on an individual basis and not as they may effect the complete product.

Warranty coverage does not include cosmetic abnormalities such as scratches, nicks, dents, oxidation of paint, or other cosmetic changes that do not interfere with the designed function of the unit.

This warranty does not include failure of the product due to alteration, modifications, misuse, abuse, improper maintenance, improper installation or repair.

This warranty is not transferable and is only applicable to the original purchaser named on a completed and registered warranty record at Sun Industries, Inc.'s headquarters.

Sun Industries, Inc. obligations do *not* include transportation charges on the shipping of new components to the customer or on the return of defective components to the manufacturer. All freight charges must be paid by the customer.

**THIS WARRANTY IS EXPRESSLY IN LIEU OF ALL OTHER WARRANTIES, EXPRESSED OR IMPLIED, INCLUDING THE WARRANTIES OF MERCHANTABILITY AND FITNESS. NO PERSON, FIRM OR CORPORATION IS AUTHORIZED TO OBLIGATE SUN INDUSTRIES, INC. FOR ANY LIABILITY IN CONNECTION WITH THE SALE OR USE OF THESE GOODS.**

This warranty gives you specific legal rights, and you may also have other rights which vary from state to state.

