

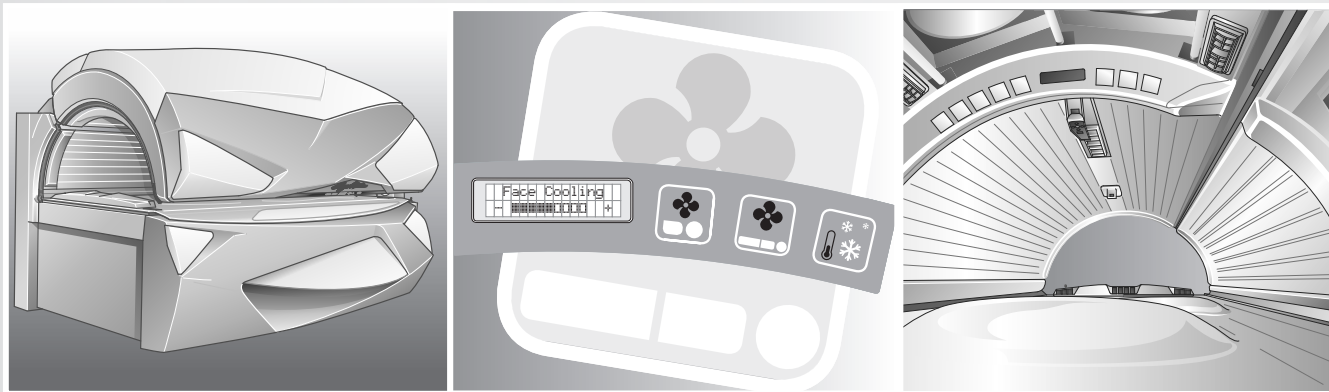

OPERATING INSTRUCTIONS



Ergoline

PRESTIGE 1000

**INTELLIGENT
PERFORMANCE**

USA

CDN

EXPOSURE
10 min
TIME

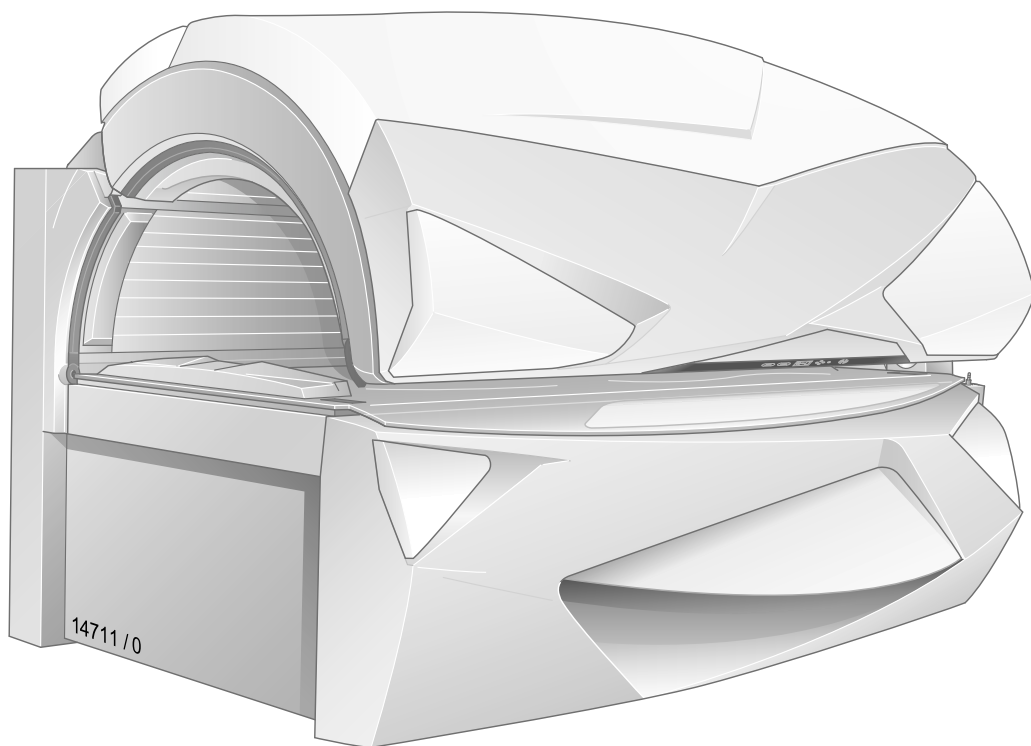

Operating instructions

Ergoline PRESTIGE 1000

INTELLIGENT PERFORMANCE

1013658-00 / us / 08.2013

Contact information

Technical Service JK Products & Services, Inc.

#1 Walter Kratz Drive
Jonesboro, AR 72401
Phone: 800-445-0624 (toll-free)
Fax: 870-935-9046
e-mail: support@jkamerica.com
<http://support.jkamerica.com>

WARNING!



WARNING!

Read these operating instructions.

Failure to observe these instructions:

- may result in serious injury and death,
- can result in damage to the device and the environment.
- For the safety of yourself and others, read and observe all instructions contained herein before operating the tanning system.
- Please make the instructions and additional information available to anyone who operates or services the tanning system.

Copyright

The copyright remains with JK-Holding GmbH.

The contents may not be duplicated (in whole or part), distributed or utilized for competition purposes without authorization or disclosed to other parties.

The right to make technical changes in regard to the figures and information contained in this instruction manual is reserved!

Table of contents

1	Important information on tanning.....	6
1.1	Skin types	6
1.2	Tanning times.....	6
2	General.....	7
2.1	Definitions	7
2.2	Identify your tanning device	7
3	Safety notes.....	8
3.1	Description of warning signs	8
3.2	Instructions pertaining to a risk of fire, electric shock, or injury	9
3.3	Instructions pertaining to a risk of damage to the machine	11
4	Information for the studio operator	12
4.1	Intended use	12
4.2	Foreseeable misuse.....	12
4.3	Obligations of the studio operator	12
4.4	Staff training	13
4.5	Guidelines	13
4.6	Installation location.....	13
4.6.1	Ventilation	13
4.7	Export.....	13
4.8	MP3 music	14
4.9	Disposal	14
4.9.1	Environmental regulations – disposal of lamps	14
4.10	Instruction signs on the device.....	14
4.11	Technical modifications.....	14
5	Description	15
5.1	Scope of delivery.....	15
5.1.1	Optional.....	15
5.2	Equipment.....	15
5.3	Device description	16
5.4	Accessories (optional).....	17
5.5	Function description	17
6	Operation	18
6.1	Mandatory reading	18
6.2	Use the tanning device – but use it properly!	19
6.3	Operation overview	20
6.3.1	Operating panel and operating handle	20
6.3.2	Multifunction panel	21
6.3.3	Navigation	21
6.4	Operating structure	22

6.5	Functions.....	22
6.5.1	Operating panel.....	22
6.5.2	Multifunction panel overview	24
6.6	Start.....	26
6.6.1	Preparation time.....	26
6.6.2	Interrupt or end tanning session	26
6.7	Connect MP3 player.....	27
7	Cleaning and maintenance	28
7.1	Safety instructions for cleaning and maintenance	28
7.2	Faults.....	29
7.3	Cleaning	30
7.3.1	Disinfection.....	30
7.3.2	Cleaning of surfaces.....	30
7.3.3	Filter panels and lamps	31
7.4	Cleaning plan	31
7.5	Maintenance.....	32
7.5.1	Acrylic panel.....	33
7.6	Maintenance plan.....	33
7.7	Cleaning and maintenance work preparation	36
7.7.1	Service kit.....	36
7.7.2	Lift up the acrylic panel and remove the partition	37
7.7.3	Remove the canopy panel.....	38
7.7.4	Remove the side section panel	39
7.7.5	Open the bed base.....	40
7.8	Instructions for replacing the lamps.....	41
7.8.1	Changing the chip card	41
7.8.2	Low pressure lamps	42
7.8.3	Starter.....	43
7.8.4	High pressure lamps and filter panels	43
7.9	Cleaning or replacing UV lamps in the base	45
7.10	Cleaning or replacing the UV lamps in the side section	45
7.11	Cleaning or replacing UV lamps and filter panels in the canopy.....	46
7.12	Cleaning or replacing the UV lamps and filter panels in the shoulder tanner.....	47
7.13	Cleaning the filters in the base	49
7.14	Cleaning the canopy filter mats	50
7.15	Air conditioning: Empty the condensation tank and clean the filter	51
7.16	AQUA / AROMA SYSTEM maintenance.....	54
7.16.1	Changing the AROMA canister	54
7.16.2	Replacing the AQUA SYSTEM canister	55

8	Technical data	57
8.1	Power rating, electrical specifications and noise level	57
8.2	Dimensions	58
8.3	Lamp configuration.....	59
8.3.1	Prestige 1000 Intelligent Performance	59
8.4	Spare parts and accessories.....	60
9	JK-Products, Inc. – Limited Warranty	61
9.1	Limited Acrylic Warranty	62
9.2	Warranty Claims.....	62
9.2.1	Policy & Procedures.....	62
9.2.2	Labor Warranty Claim/Credit Procedures	63
9.3	Limited Lifetime Warranty	64
10	Appendix.....	67
10.1	Signs and stickers on the device.....	67
11	Index.....	71

1 Important information on tanning

1.1 Skin types

Skin type I (Sensitive):

Invariably gets sunburn, accepts little natural sunlight and does not tan.



Skin type II (Fair):

Gets sunburn easily and severely, tans minimally or lightly and peels.



Skin type III (Average):

Often referred to as 'Average' complexion, gets moderate sunburns and tans about average.



Skin type IV (Brown):

Seldom gets sunburns, tans easily and above average with each exposure.

Skin type V (Dark Brown):

This individual's system rarely gets sunburns, tans easily and substantially.

1.2 Tanning times

This product is in conformity with performance standards for sunlamp products under 21 CFR 1040.

DANGER ULTRAVIOLET RADIATION		Recommended Exposure Schedule					
Follow instructions. Avoid over-exposure as with natural sunlight. Over-exposure can cause eye and skin injury and allergic reactions. Repeated exposure may cause premature aging of the skin and skin cancer.		Skin Type	Week 1 1st - 3rd Treatments	Week 2 4th - 6th Treatments	Week 3 7th - 10th Treatments	Week 4 11th - 15th Treatments	Weekly Subsequent Treatments
MAXIMUM TANNING TIME: 10 MINUTES		I - Sensitive	Not Advised	Not Advised	Not Advised	Not Advised	Not Advised
		II - Fair	2 Min.	4 Min.	6 Min.	8 Min.	10 Min.
		III - Average	2 Min.	4 Min.	6 Min.	8 Min.	10 Min.
		IV - Brown	2 Min.	6 Min.	8 Min.	10 Min.	10 Min.
		V - Dark Brown	2 Min.	6 Min.	8 Min.	10 Min.	10 Min.

WEAR PROTECTIVE EYEWEAR! Failure to do so may result in severe burns or long term injury to the eyes.	This unit utilizes UV lamps. Replace only with Ergoline INTELLIGENT PERFORMANCE 200 W VHP 10, Ergoline VHP B-POWER (low pressure/facial-tanner), Ergoline ULTRA 520 W C12645 (high pressure/ facial-tanner) and Ergoline ULTRA 250 W S1500384 (high pressure/ shoulder tanner) or recognized equivalents. To obtain recommended exposure at a minimum distance of 1/2" (13 mm) measured with a standard ruler, lie on acrylic surface of lounge and lower canopy. Canopy will stop at the correct distance from lounge acrylic surface.
Certain medications or cosmetics may increase your sensitivity to the ultraviolet radiation. Consult a physician before using sunlamps if you are using medication, have a history of skin problems or believe yourself to be especially sensitive to sunlight. If you do not tan in the sun, you are unlikely to tan from the use of this product.	
Warning: The use of any other position may result in overexposure!	

Tanning can begin on a regular basis. An appearance of tanning normally appears after a few exposures and maximizes after four (4) weeks of exposure following the recommended exposure schedule for skin type. In order to provide for maintenance of a tan a maximum of two (2) weekly 10 minute sessions is recommended from the fifth week onward. Do not tan more than once in a 24 hour period.	Use protective eyewear, super sunnies, when ever unit is energized. Read and follow instruction booklet before using this product. To avoid electrical shock during maintenance disconnect power from unit. This product is in conformity with performance standards for sunlamp products under 21CFR 1040, FDA. <small>Part No: 1014403-00</small>
---	--

2 General

2.1 Definitions

Operator

People who provide tanning devices to users on a commercial basis. The operator is responsible for the orderly operation of the device as well as compliance with the maintenance intervals.

User

A person who uses the tanning device at a commercial location.

Staff

People who are responsible for the operation, cleaning as well as general maintenance work and who instruct the users in the operation of the devices.

Electrician

A person with suitable professional training, knowledge and experience which enables them to identify and avoid the dangers which can arise from working with electricity.

Authorized, trained and qualified staff

Qualified staff from an external company who have been trained and authorized by the manufacturer for assembly and maintenance work with specific tanning devices.

2.2 Identify your tanning device

For contact with Customer Services, please write down the device number of your tanning device, see page 67.

3 Safety notes

3.1 Description of warning signs

Danger notices, damage to persons:

DANGER!

 **DANGER!** Type and source of danger, e.g. 'DANGER – High voltage!'
Description of the consequences, e.g. 'You can be killed or injured by an electric shock!'
Countermeasures:

- Disconnect device from power supply before opening.
- Do not reach into the inside with the device switched on.

Warning notices, damage to persons:

WARNING!

 **WARNING!** Type and source of danger, e.g. 'WARNING – hot surface!'
Description of the consequences, e.g. 'You can burn your hand (skin, face)!'
Countermeasures:

- Do not touch hot parts and nearby surfaces.
- Wait until hot parts and surfaces have cooled down.

Caution notices, damage to property:

CAUTION!

 The word 'Caution' with this label points out that danger for devices, materials and the environment can be expected here.

Important information:



NOTE:

This symbol does not identify safety notices, but states information for a better understanding of the processes.

3.2 Instructions pertaining to a risk of fire, electric shock, or injury

DANGER – HIGH VOLTAGE!



DANGER!

You can be killed or injured by an electric shock!

Assembly and electrical connection must comply with national and local regulations.

- The device may only be assembled, installed, upgraded or repaired by specially trained and instructed personnel.

WARNING!



WARNING!

Unprotected tanning may result in eye injury and eye diseases!

The unprotected eye can become inflamed on the surface, and in certain cases the retina can be damaged by excessive radiation. Cataracts can form after repeated exposure to radiation.

- **Inform users to use the included protective goggles that block UV.**

WARNING!



WARNING!

Follow instructions!

Failure to use protective eyewear may result in severe burns or other eye injury. If discomfort develops, discontinue use and consult a physician.

- A person who does not tan in the sun most likely will not tan from the use of this device. Persons with very sensitive skins (skin type I) must not use the unit as their skin may be too sensitive for the lowest dosage. Damage to the skin (e.g. sunburn) may occur.
- Individuals with acute sunburn, individuals who have had or have skin cancer, or individuals who are at increased risk of skin cancer, must not use the system.
- Seek medical advice if you experience any unexpected effects, including itching, from using this UV device.
- The tanning device must never be used if a filter panel is missing or damaged, or the timer is defective!
- UV light from the sun or UV systems can cause injuries to the skin or eyes. This effect is dependent on the sensitivity of the individual's skin and on the type and amount of UV light.
- As with natural sunlight, overexposure can cause eye and skin injury, sunburn, and allergic reactions.
- Repeated exposure may cause premature aging of the skin and skin cancer.

- Medications (taken internally or otherwise) or cosmetics applied to the skin, may increase sensitivity to ultraviolet light.
 - A person having a history of skin problems should consult a physician before use.
-

WARNING!



WARNING!

Danger of long-term consequences!

- Overexposure should be avoided.
 - Children may not use this device.
 - The following applies to minors under the age of 18 years: Only use tanning devices in agreement with a parent or guardian, or after consulting a physician. Check with your state regarding tanning laws for minors!
 - While there is no immediate clinical evidence of UV exposure and its effects upon expectant mothers, it is strongly advised that expectant mothers be discouraged from using the tanning unit.
-

WARNING!



WARNING!

Infections can be transferred through skin contact.

All items/equipment components, with which the user can come into contact during tanning, must be disinfected after every tanning session:

- Protective goggles
 - Acrylic panel
 - Handles and control panel
 - MP3 cable
 - Adjustable air nozzles
 - Use only approved cleaners to disinfect the tanning system and its components.
-

**NOTE:**

Occasionally, persons using the tanning device will experience a slight reddening of the skin – usually in small patches – after the second or third session. This redness is often accompanied by an itching sensation. This may be nothing more than a very limited heat 'rash' caused by heat from the lamps within the device and it should go away within approximately 24 hours and not reappear. This rash can be lessened or prevented by applying moisturizing lotion to the affected area after the tanning session is completed.

- Follow instructions.
- The time between the first two tanning sessions must be at least 24 hours.
- Increasing tanning also requires an extension of the exposure time (= radiation time). After a certain degree of tanning has been achieved a further intensification is not possible. The session time may not be extended to exceed the scope of the permissible radiation doses! Only a certain degree of tanning, dependent on the skin type, can be achieved without endangering your health.
- Inform users about proper tanning.

3.3 Instructions pertaining to a risk of damage to the machine

CAUTION!**Danger of overheating by obstruction of the air routing!**

- Do not change, obstruct or block the air inflow and outflow area to the device or make any unauthorized changes to the device. The manufacturer shall bear no liability for damage or injuries resulting from such actions.
- Before putting a tanning device into operation, the transport pallet must be removed from under the device. Danger of overheating by obstruction of the air routing.

4 Information for the studio operator

4.1 Intended use

The tanning device is intended exclusively for cosmetic tanning of the human skin.

- This device is used for tanning one adult person at a time.
- The user must wear suitable eye protection to block UV radiation during tanning.

Any other use shall be considered improper. The manufacturer cannot be held liable for damage or injuries resulting from misuse. The operator bears the sole risk for this.

The proper use also includes compliance with the manufacturer's instructions, operating and maintenance conditions. This device may only be operated, maintained and repaired by persons familiar with these tasks and who are aware of the dangers involved.

4.2 Foreseeable misuse

The following uses of the device are explicitly prohibited:

- Multiple people may not use the device at the same time.
- People with body weight of more than 300 lb (135 kg) may not use the device.
- Exceeding the specified tanning times may result in burns and long-term skin damage.
- When the device is in use no other people may remain in the room. This includes both children and adults.

4.3 Obligations of the studio operator

- As the operator you are responsible for informing users on possible risks of tanning.
- All danger and safety labels attached to the device must be observed! Do not remove them!
- No safety equipment (e.g. panel switch) may be removed, deactivated, or otherwise bypassed as it can impair the safe operation of the device!
- The device may only be used when in completely operational condition!
- It is the operator's responsibility to ensure the tanning system is handled properly.

4.4 Staff training

As the operator you are obligated to train your personnel and instruct them in the established legal and accident prevention regulations. Ensure that your staff have understood and observe these instructions. This includes:

- information regarding intended use and foreseeable misuse
- safety instructions
- operating instructions
- cleaning and maintenance instructions
- Please make the instructions and additional information from the manufacturer available to the staff at their workplace.
- Regularly check your staff's safety consciousness of the risks, taking into account your operating instructions.
- Please ensure that the cleaning intervals are complied with, in particular cleaning after every use.
- Please ensure that your staff provide your customers with appropriate advice, in particular regarding tanning times, possible risks and the operation of the device.

4.5 Guidelines

This product is in conformity with the performance standards for sunlamp products under 21 CFR 1040.20-M 89, FDA and listed with ETL and CAN/CSA 22.2 No. 224 R 2004.

4.6 Installation location

4.6.1 Ventilation

CAUTION!



Danger of failure!

Danger of overheating by obstruction of the air routing.

- Observe the ventilation information to avoid serious system malfunctions.

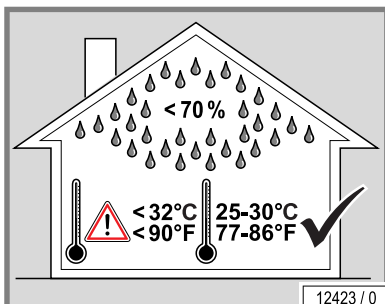

You can obtain data regarding the air supply and ventilation from the customer service department (see page 2).

4.7 Export

This device is exclusively intended for use in the USA and Canada and may not be exported to other countries and operated there! The manufacturer assumes no liability whatsoever in the event of non-compliance. High liability risks may occur for the exporter and/or the operator in the event of non-compliance.

4.8 MP3 music

The personal use of an MP3 player or a smartphone during tanning is not a public broadcast in copyright terms, so that there is no obligation for registration or payment by the studio owner to the corresponding copyright owning company. Copyright laws apply to the owner of the MP3 player or smartphone.

The same regulations apply for the official use of MP3 music files as for other music sources: As studio owner you are only allowed to use original audio obtained from legal sources. Proof of the legitimacy of any MP3 audio used should be available for viewing upon demand of any regulatory body. Please refer to <http://www.riaa.com> for more information.



NOTE:

Pre-recorded SD cards which are delivered as accessories for a JK audio system are also subject to payment obligation for commercial usage.

4.9 Disposal

4.9.1 Environmental regulations – disposal of lamps

UV low pressure lamps and UV high pressure lamps contain fluorescent materials and other waste containing mercury.

According to the national waste disposal laws and in accordance with the municipal waste regulations, proof must be provided of the proper disposal of UV lamps.

Contact your local environmental agency for assistance with the disposal of UV lamps.

4.10 Instruction signs on the device

See Appendix page 67.

4.11 Technical modifications

The device has been constructed in accordance with current safety regulations. The illustrations and specifications on these instructions are subject to technical modifications which are required in order to improve the device.

Unauthorized modifications and changes to the device and its control unit are prohibited.

Use only OEM spare parts.

5 Description

5.1 Scope of delivery

- Tanning device
- Lamps
- Shoulder tanner with audio system (with Voice Guide)
- Air conditioning system
- Connecting lead
- Protective goggles
- Suction cup for filter panels
- Allen-key
- Technical documentation (folder with instructions, brochures for error codes and default settings and additional documentation)

5.1.1 Optional

- Central exhaust air socket

5.2 Equipment

Device equipment varies depending on the model.

In this description, all standard and optional components/functions are taken into account which must be observed during operation and/or when performing maintenance.

The control panel also differs according to the varying equipment: Only those buttons that are visible can be operated, i.e. the corresponding function must be included in the device's equipment.

5.3 Device description

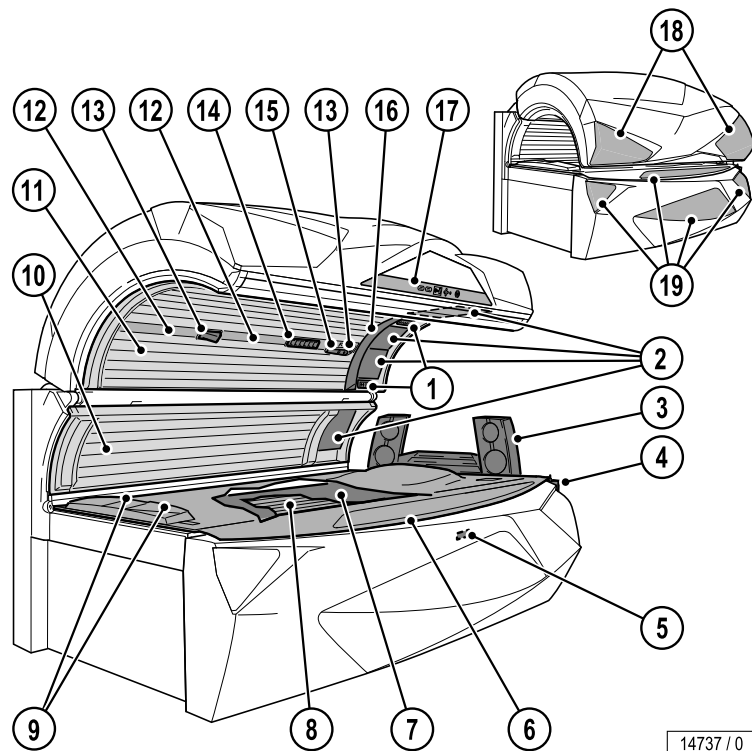

1. Adjustable air nozzles – Facial cooling
2. Facial tanner (UV high pressure lamps + UV low pressure lamps)
3. Shoulder tanner with audio system (with Voice Guide)
4. Headphones and MP3 connection
5. Infrared interface
6. Acrylic panel base
7. Partition
8. UV low pressure lamps, base
9. Body cooling air nozzles, foot end
10. UV low pressure lamps, side section
11. UV low pressure lamps, canopy
12. Interior lighting (LED)
13. Nozzles AQUA / AROMA SYSTEM
14. Body cooling air nozzles
15. Operating handle
16. Display unit
17. Multifunction panel
18. Accent lighting, canopy (LED)
19. Accent lighting, front panel (LED)

5.4 Accessories (optional)

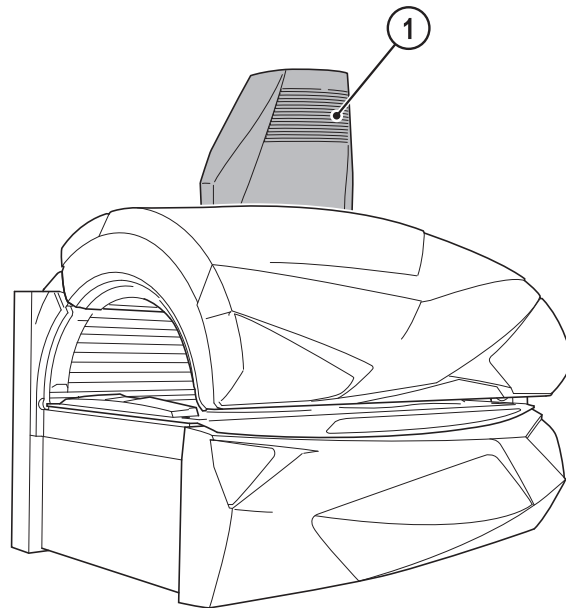

14732 / 0

1. Central exhaust air socket

5.5 Function description

Tanning

The primary technical components of a tanning device are an artificial source of UV radiation, a variety of filters and reflectors as well as a mechanical structure with a defined active surface.

Different tanning results can be achieved in varying strength tanning devices. This is due to the different strength UV lamps and the different UV-A and UV-B proportions of the UV radiation. The UV-A proportion primarily generates a superficial tan, which appears rapidly and is intensive but also fades more rapidly, the UV-B radiation is primarily responsible for more long-term tanning results. The disadvantage of the UV-B radiation is that the tan does not become visible until one or two days after visiting the tanning salon. Therefore, the appropriate tanning device is to be selected depending on the desired tanning goal.

NFC point

Near field communication (NFC) is a communication standard between smartphones and similar devices that allows contactless data exchange. Communication is also possible between an NFC device and an unpowered NFC chip.

The NFC point of this tanning device for example may be used to store basic settings on a chipcard. These settings can be read for the next session and may be changed if necessary.

6 Operation

6.1 Mandatory reading

Always read and follow all instructions for proper usage prior to allowing anyone to use the tanning device. The operating instructions included with this device must always be followed to prevent possible injuries.

Inform users

- to use provided UV-blocking protective eyewear whenever the equipment is energized.
- to follow the exposure schedule in accordance with their skin type. Failure to do so may result in overexposure.

A tanning system is not a toy. You cannot vary the strength of the lamps in your unit.

Should you have any questions regarding the proper use of your tanning system, contact Global Service USA at:

Phone: 800-445-0624 (toll-free)

Mon - Fri. 8:00 a.m. to 7:00 p.m. (CT)

Sat. 8:00 a.m. to 3:00 p.m. (CT)

WARNING!



WARNING!

Danger of skin injuries and skin diseases.

- The tanning device must never be used when a filter panel is missing or damaged, or the timer is defective!



NOTE:

When describing the operation, the tanning device is often shown with the canopy open. During tanning the canopy must always be closed.

Proper operation is not possible with the canopy open.

6.2 Use the tanning device – but use it properly!

A few things need to be noted to in order to obtain maximum enjoyment from a tanning device. Here are some answers to frequently asked questions.

Make-up in the tanning device?

Please do not wear make-up. Clean skin absorbs UV light better.

A wide variety of materials is found in cosmetics. Whether these are emulsifiers, greases, or fragrances - in conjunction with UV radiation, these can cause skin allergy reactions.

Remove all make-up. This is essential. Make-up clogs the pores in the face. The UV light from a tanning device re-opens these clogged pores so that not only does the light penetrate the skin, but also the allergenic components of the make-up.

A further negative consequence of make-up is that the appearance of the skin deteriorates irreversibly over a period of time. However good make-up looks - in conjunction with UV light, it causes more harm than good. Therefore remove all make-up before a session in your tanning device - it will be much better applied afterwards.

Showering after leaving the tanning device?

The browning is in the skin, not on it. Therefore you cannot wash it off. Treat your skin to a moisturizing cream after showering.

Are medications and the tanning device compatible?

It is known that some medications increase the skin's sensitivity to UV light. This probability is particularly high with antibiotics, sulphonamides, psychiatric drugs, tranquillizers, anti-diabetes treatments and diuretics. Sun creams which contain psorale or kumarin also increase skin sensitivity. If you are in any doubt, first ask your doctor - then you can enjoy the sun at no risk.

Contact lenses in the tanning device?

The answer is: Yes! Like any other tanning device user, contact lens wearers should also wear special protective goggles which protect the eyes against UV radiation. To guarantee better protection, wearers of glasses and contact lenses can ask their optician for exchange contact lenses with UV protection. The UV-A and UV-B filters built into exchange contact lenses will protect the cornea and the internal parts of the eye against almost 100 % of the energy in UV radiation.

This will benefit tanning device users not only in the open air, but on the tanning device itself. You can wear these contact lenses on the tanning device without any restrictions. For more information, ask your optician or optometrist.

6.3 Operation overview

6.3.1 Operating panel and operating handle

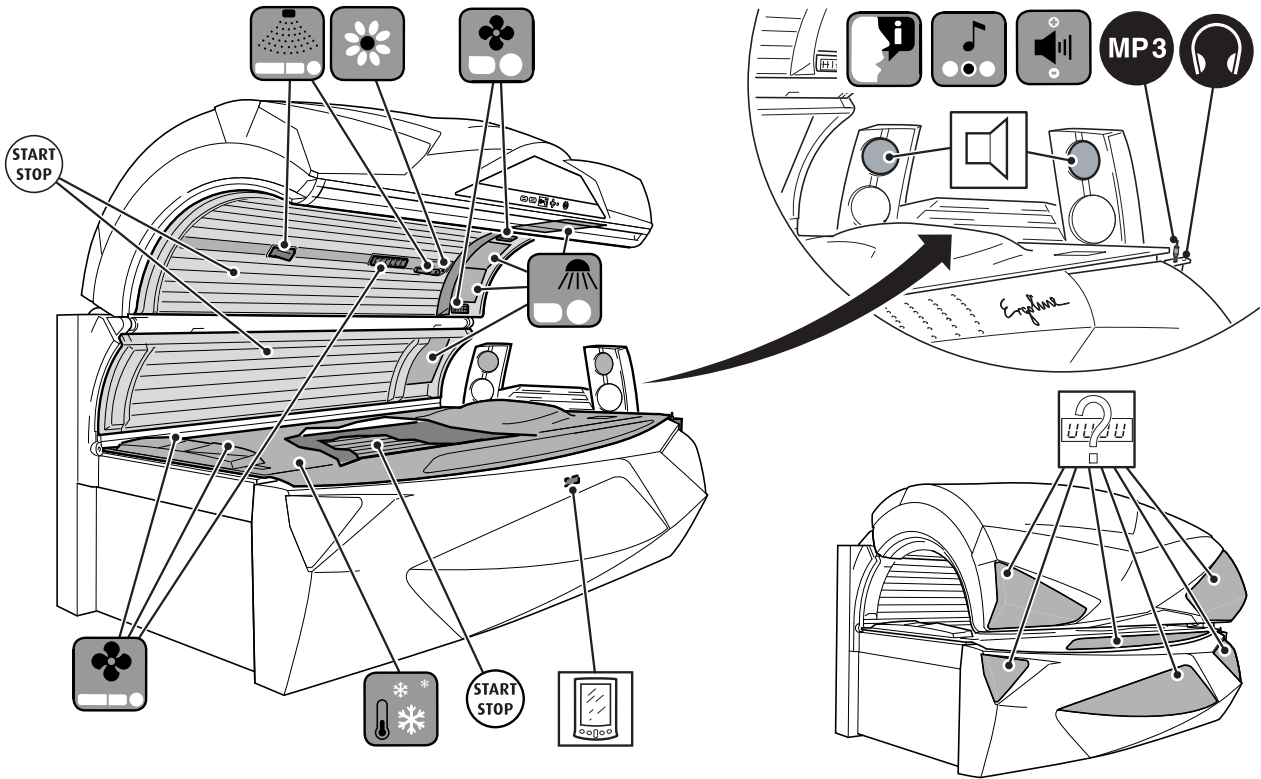

14774 / 0

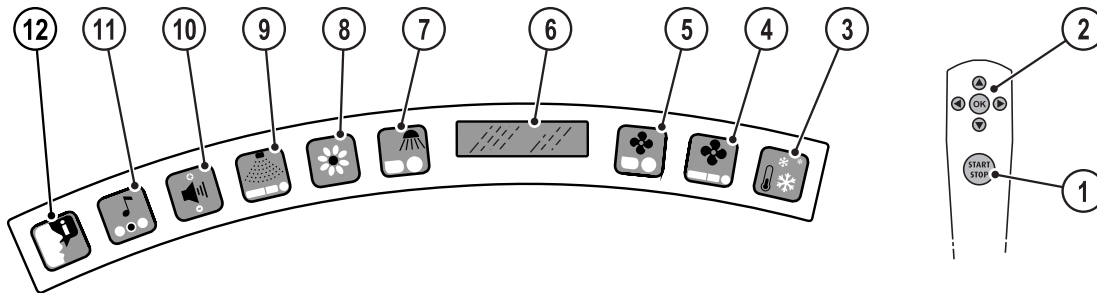

14775 / 0

2. START/STOP button
3. Navigation unit
4. Temptronic indicator
5. Body fan indicator
6. Facial fan indicator
7. Display – Functions ...
8. Facial tanner indicator
9. AROMA indicator
10. AQUA SYSTEM indicator
11. Volume indicator
12. Audio system/channel indicator
13. Voice Guide indicator



Infrared interface

6.3.2 Multifunction panel

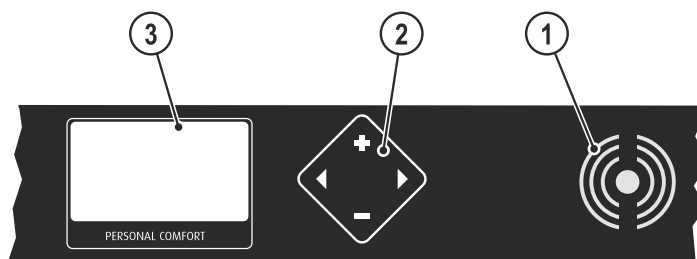

14876 / 0

1. NFC point
2. Navigation unit
3. Display

6.3.3 Navigation

Navigation unit – multifunction panel

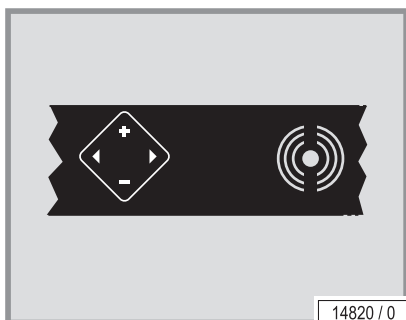

14820 / 0



Select device function or setting.



Enable, disable or change selected function or setting.



NFC point

Data transfer via near field communication – individual settings may be stored on a chipcard and be reloaded for the next session.

Navigation unit – operating handle

The tanning device is operated using the buttons mounted in the operating handle in the canopy.

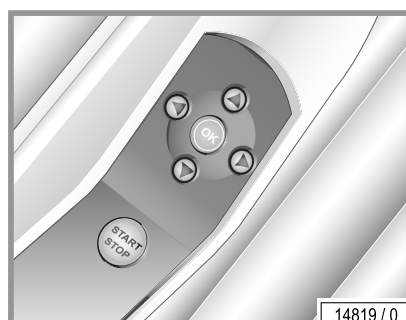

14819 / 0



Switch tanning on and off, pause.



Confirm function.
This button's availability is displayed on the screen, depending on the function that has been selected.



Select device function
(go to indicator).



Select the sub-function (if available).
Alter the setting (for progress bar display), e.g. regulating the temperature.
Change music title or studio channel (from default mode).
The availability of these buttons is displayed on the screen, depending on the function that was selected.

All of the indicators displayed on the screen are illuminated in default mode after the tanning device starts up.

The relevant indicator will start to flash after a device function has been selected. The settings or selection options available for the selected function will be displayed on the screen, see 'Operating structure' on page 21.



NOTE:

If a button is not pressed within 8 seconds, the settings return to default mode.



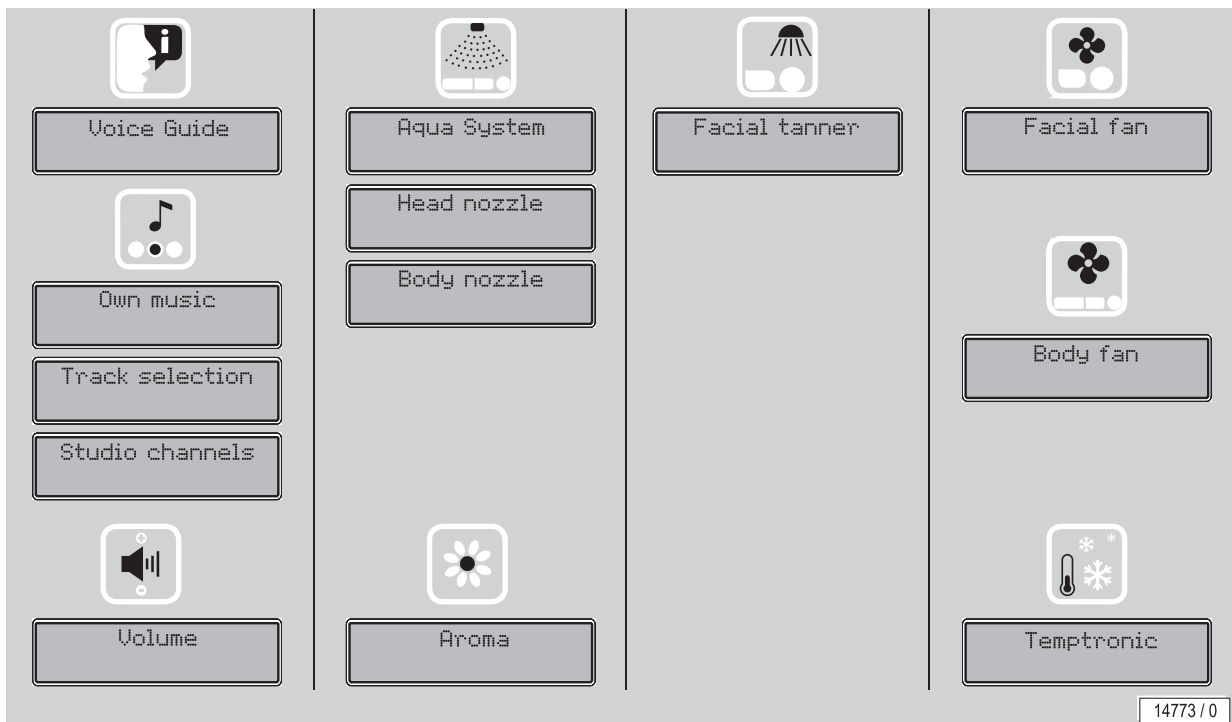























6.4 Operating structure











6.5 Functions

6.5.1 Operating panel

Function	Indicator selection / key sequence	Description / Display	Information
1. UV lamps		START/STOP Switches the UV lamps on / off during the tanning session	The tanning time continues to run if the UV lamps are switched off during tanning session.
3. Temptronic		Regulate the temperature, levels 1 - 9	The acrylic panel will be cooled without adjustment control if the automatic air conditioning (Temptronic) fails. The user can only switch the cooling system on or off in this case.

Function	Indicator selection / key sequence	Description / Display	Information
3. Air conditioning (Temptronic) failure	 1.  2. 	Switch the air conditioning off: hold button down	
	 	Switch the air conditioning on	
4. Body fan	 	Regulate the body fan, levels 1 - 9	
5. Facial fan	 	Regulate the facial fan, levels 1 - 9	 The face cooling air nozzles can be adjusted manually.
7. Facial tanner	 	Regulate the facial tanner, levels 1 - 4	
	 1.  2. 	Switch the facial tanner off, hold button down: 'Facial tanner off? OK'	
	 	Switch the facial tanner on	1 minute until up to maximum power, then return to the previous setting before switching off.
8. AROMA	 1.   2. 	Switch the AROMA on: 'Aroma on? OK'	
		Switch the AROMA off: 'Aroma off? OK'	
9. AQUA SYSTEM	 1.   2. 	Activate the AQUA SYSTEM pulse: 'AQUA SYSTEM pulse on? OK'	
		Switch the AQUA SYSTEM comfort program on: 'Comfort program on? OK'	
		Switch the AQUA SYSTEM comfort program off: 'Comfort program off? OK'	
		Switch the AQUA SYSTEM head nozzle on: 'Head nozzle on? OK'	
		Switch the AQUA SYSTEM head nozzle off: 'Head nozzle off? OK'	
		Switch the AQUA SYSTEM body nozzle on: 'Body nozzle on? OK'	
		Switch the AQUA SYSTEM body nozzle off: 'Body nozzle off? OK'	
10. Volume	 	Volume control	

Function	Indicator selection / key sequence	Description / Display	Information
11. Audio system	 1.  /  2. 	Select audio system: A: Own music, MP3 player B: Track selection, 'Music' SD-card C: Studio channels, externally connected system (e.g. CD/DVD player) Example: Select the studio channel as the audio system 'Studio channel on? OK' Changing the music track or studio music channel	Selecting a specific audio system automatically deactivates the others.
12. Voice Guide	 1.  /  2. 	Switch the Voice Guide off: 'Voice Guide off? OK' Switch the Voice Guide on: 'Voice Guide on? OK'	The Voice Guide provides acoustic device operating help and is only available if an audio system is fitted. Voice Guide is switched on as a standard item during stand-by and tanning.

6.5.2 Multifunction panel overview

The multifunction panel allows comfortable access to special functions. Individual settings may be stored on a chipcard and read back as needed. Navigation see Navigation unit – multifunction panel on page 21.

Select a program

If multifunction is not used, the tanning device starts with standard settings.

Adjust basic settings

- Select Comfort settings on the display of the multifunction panel.
- To adjust the cooling temperature of the air condition or Temptronic, select the air condition symbol.

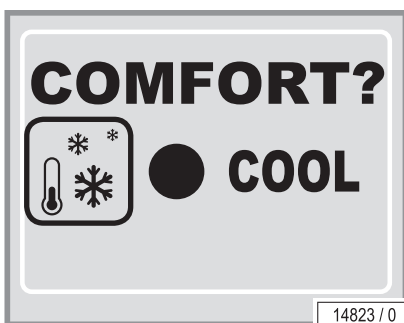

- With  or  select the temperature setting, e.g. cool or warm.

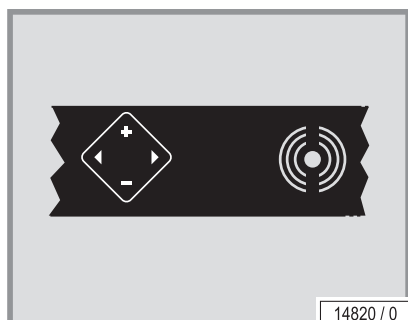

Using the NFC point to store settings

- Adjust all basic functions.
- Get a new chipcard.
- Hold the chip close to the NFC point.
Maximum distance is about 1 ½ in/3 cm.

The settings are stored on the chipcard.



Restore settings from a chipcard

- Hold the chip close to the NFC point.
Maximum distance is about 1 ½ in/3 cm.

The settings are restored.

NFC status signal

Data transfer is signalled by color:



NFC point whole-colored pink/magenta:
Ready/standby



Green center of NFC point:
Data are successfully transferred from tanning device to chipcard



Blue center of NFC point:
Data are successfully transferred from chipcard to tanning device



White center of NFC point:
Data transfer failed

6.6 Start

The device is started automatically with an internal or external timer.



NOTE:

Timer instructions see separate manual (order no. 1008370-..).

6.6.1 Preparation time

Before the UV lamps turn on, you have a few minutes to prepare yourself. During the preparation time you can switch on the UV lamps at any time by pressing the START/STOP button.

- Remove your clothes and all jewelry.
- Remove make-up and other cosmetics.
- Remove glasses. Contact lenses can be worn under the protective goggles.
- Put on the protective goggles.
- Lie down on the bed surface.
- Close the canopy.
- Press the START/STOP button.

Settings on start-up:

- UV lamps
- Facial tanner
- Shoulder tanner
- Body cooling
- Facial cooling
- Audio system
- Voice Guide

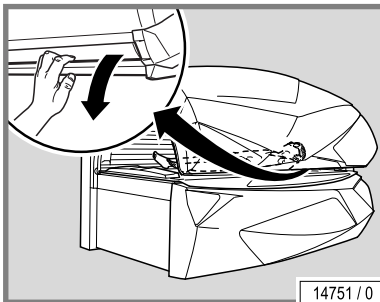

6.6.2 Interrupt or end tanning session

The tanning session ends automatically after the preset time has run down. The internal body cooling fan continues to run for approx. three (3) minutes to sufficiently cool the device.

- To interrupt a tanning session, press and hold button START/STOP any-time during a session.
- Press START/STOP again to restart the lamps.

6.7 Connect MP3 player

DANGER!



DANGER!

Danger of hearing damage!

Using earphones or headphones at high volume can result in permanent hearing damage.

- Do not set the volume too high.

The user can connect their own private MP3 player or smartphone to the device.

1. Jack plug (JK Part # 4630911001-..) provided for use by the studio operator (2 x 3.5 mm stereo jack plug).
2. MP3 player or smartphone connection: see the documentation from the manufacturer of the MP3 player or smartphone.

Connecting:

- Insert the MP3 cable (stereo jack plug) in the audio system.
- Plug the MP3 cable into the MP3 player or smartphone.
- Select the music title and then start.
- Where necessary, set the volume level on the MP3 player or smartphone so that the sound signal from the MP3 player or smartphone is recognized by the audio system.

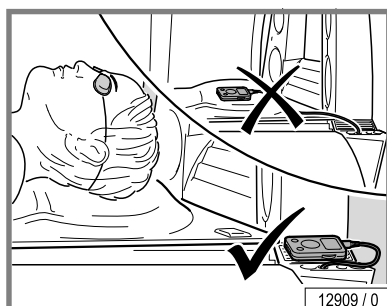
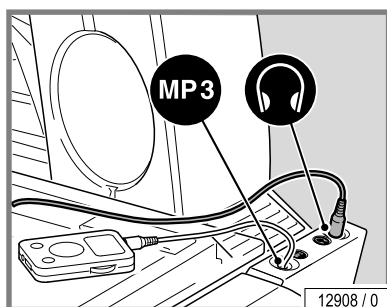
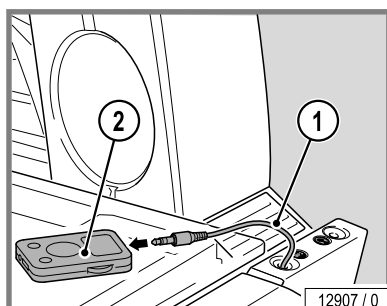

CAUTION!



The heat might damage your MP3 player or smartphone!

- Do not position the unit so that it receives direct tanning radiation.

CAUTION!



Cable may be torn off, connectors may be damaged!

- Do not pull on cable when unplugging MP3 player or smartphone.

7 Cleaning and maintenance

7.1 Safety instructions for cleaning and maintenance

DANGER – HIGH VOLTAGE!



DANGER!

You can be killed or injured by an electric shock!

During maintenance work there is a risk of touching live parts and receiving a fatal electric shock.

- Disconnect device from power supply before opening.
- Do not reach behind covers and do not open the device with the device switched on.
- Refit any safety devices (e.g. switches) after the work has been completed.

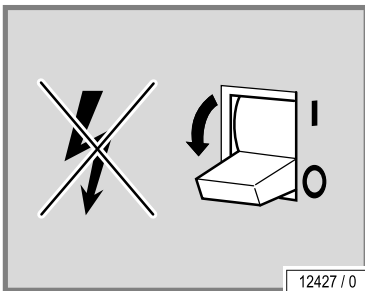

12427 / 0

If work is to be performed on the devices, they must be deenergized. That means that all live cables must be switched off.

Switching off the device alone is insufficient, as certain points may remain energized. Therefore, switch off fuses before performing any work and – if possible – remove them.

Accidental reactivation can result in serious accidents. Immediately after deenergizing, secure all switches or fuses used for deenergizing against being switched on again.

- Lock the fuse box with a padlock.

In case of circuit breakers which cannot be unscrewed, a strip of adhesive tape may be applied over the actuation lever with the wording 'Do not switch, danger!'.

A prohibition sign with the text:

'Work in progress!'

'Place:

'Sign may only be removed by:

must always be securely mounted immediately.

It is imperative that you, the owner and/or operator, check all components for any signs of wear which may occur through normal use.

- Observe the cleaning and maintenance schedule specified in the tables in Chapter 7.4 and 7.6.
- Only replace UV low-pressure lamps with the original type or compatible lamps.

Should you require any assistance or need additional information, please call Global Service USA at 800-445-0624 (toll-free), Monday through Friday 8:00 a.m. - 7:00 p.m. CT, Saturday 8:00 a.m. to 3:00 p.m.

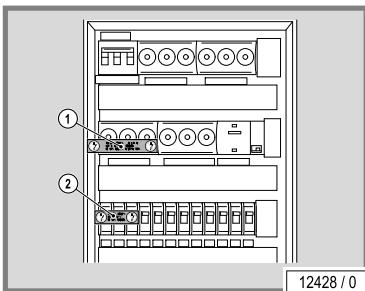

12428 / 0

WARNING!**WARNING!****Injuries and damage due to improper maintenance!**

If the maintenance intervals for the UV lamps are exceeded or incompatible UV lamps are installed, the share of UVB radiation may increase. Sunburn and other skin damage may result.

Improper maintenance can cause the device to be damaged or to become unusable.

- Always comply with the specified maintenance intervals.
- Follow the cleaning instructions.

WARNING!**WARNING!****Danger of burns from hot lamps and device parts!**

If the tanning device was operated before being switched off and opened, lamps and housing parts may be hot.

- Before replacing lamps or other spare parts, wait until lamps and metal parts of the device have cooled down sufficiently.

WARNING!**WARNING!****Danger of pinching!**

When opening and closing the panels and covers, you can pinch your fingers.

7.2 Faults

Error codes are output to the display to simplify troubleshooting:

- If a fault occurs, the error code flashes on the display.
- If several errors occur, the error messages are displayed alternately.
- Error elimination is acknowledged by pressing the **START/STOP** button.
- If the error cannot be cleared, contact Customer Service (see page 2) or your local service provider.

More detailed information regarding the error description and solutions is available in 'Error Codes' (order no. 1011831-..).

7.3 Cleaning

WARNING!



WARNING!

Infections can be transferred through skin contact.

All items/equipment components, with which the user can come into contact during tanning, must be disinfected after every tanning session:

- Protective goggles
 - Acrylic panel
 - Handles and control panel
 - MP3 cable
 - Adjustable air nozzles
 - Use only approved cleaners to disinfect the tanning system and its components.
-

7.3.1 Disinfection

For hygienic proper disinfection, use a specially developed disinfectant cleaner (such as Lucasol).



NOTE:

For thorough disinfection, the product must be allowed to remain in contact with the surface being disinfected for a specified amount of time. Follow the manufacturer's instructions for use.

7.3.2 Cleaning of surfaces

Acrylic panel

CAUTION!



Do not rub with a dry cloth – danger of scratching!

- For hygienic proper cleaning of acrylic surfaces, use a specially developed disinfectant cleaner. Other cleaning agents, especially concentrated disinfectants or solvents (e.g. Lysoform, ethyl alcohol or other liquids containing alcohol) must never be used for cleaning.

Failure to observe this voids all warranty claims.

CAUTION!



Acrylic panels unusable due to soiling!

Soiling on the panels is burned in by the hot lamps and results in the long term in unserviceable panels.

- Remove fingerprints and other soiling carefully.
-

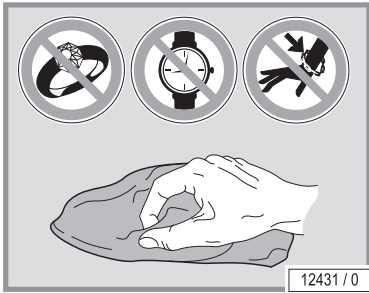

Plastic surfaces

For cleaning the remaining painted and unpainted plastic surfaces, it is best to use warm water and a cloth. Never use aggressive cleaning agents containing alcohol or essential oils. These may lead to damages not covered by the warranty.

During cleaning a slight discoloration of the cloth by the rubber seals should be expected for production-related reasons.

Prevent damage to the acrylic and plastic surfaces.

- Remove rings, watches, bracelets etc. before starting cleaning work.

7.3.3 Filter panels and lamps

- UV low pressure lamps and filter panels can be cleaned with a damp cloth (without additional cleaning agents) where necessary.
- UV high pressure lamps can be cleaned with ethyl alcohol where necessary.

7.4 Cleaning plan

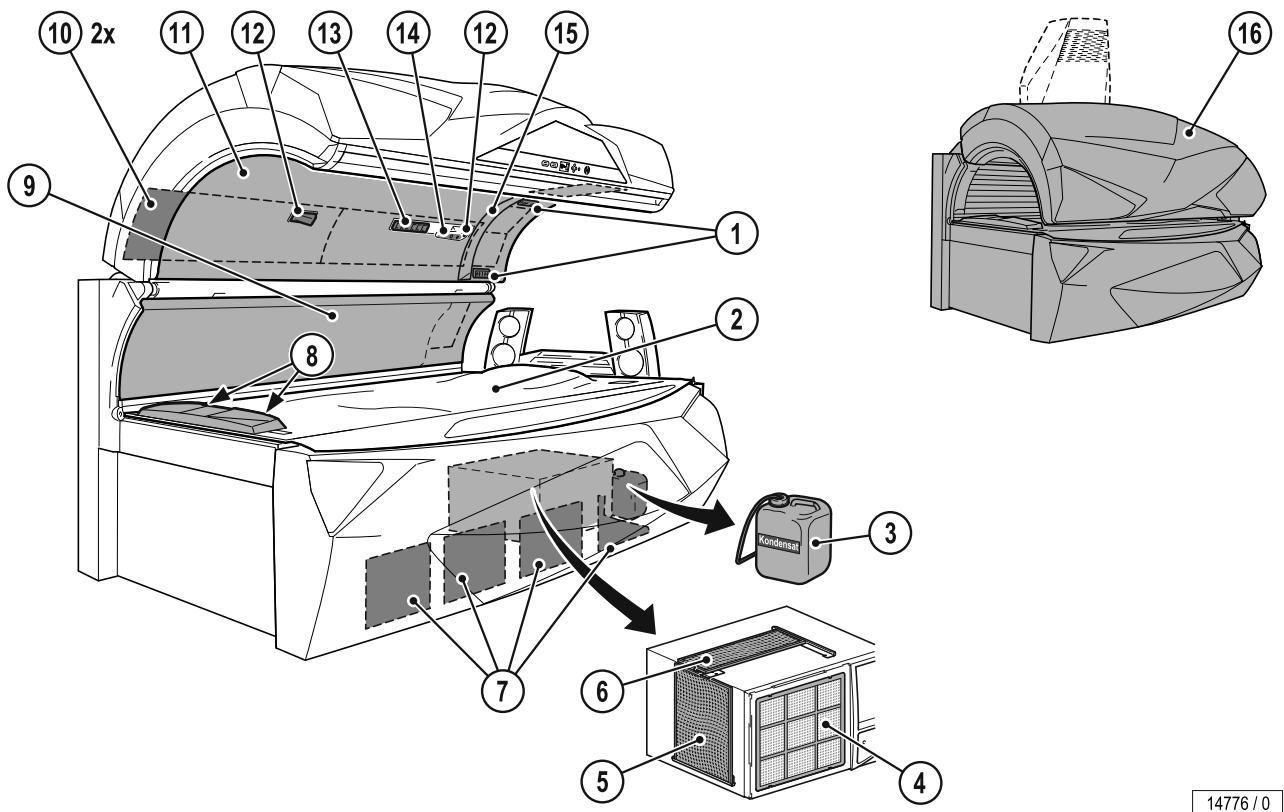

Component		Interval		Activity	See page
		After each tanning session	When necessary		
				50 h	
1	Adjustable air nozzles	X		Cleaning and disinfection	30
2	Acrylic panel	X		Cleaning and disinfection	30
14	Operating handle	X		Cleaning and disinfection	30
15	Display unit	X		Cleaning and disinfection	30
	Multifunction control panel	X		Cleaning and disinfection	30
	Handle	X		Cleaning and disinfection	30
	Protective goggles	X		Cleaning and disinfection	30
	MP3 cable	X		Cleaning and disinfection	30
3	Condensation tank		X	Empty	51
8	Body cooling air nozzles, foot end		X	Clean	30
9, 11, 16	Surfaces		X	Cleaning and disinfection	30
12	Nozzles AQUA / AROMA SYSTEM		X	Clean	30
13	Body cooling air nozzles		X	Clean	30
4-6	Filter			X Remove and clean filter	51
7	Filter			X Remove and clean filter	49
10	Filter			X Remove and clean filter	50



NOTE:

If desired, you may set the unit to require that cleaning be confirmed after each tanning session by pressing the START/STOP button (when the cool-down time for the main fan has finished).

7.5 Maintenance

Maintenance and care play a major role in deciding the devices performance and appearance over its useful life. Diligent compliance at the specified intervals is absolutely necessary to ensure the proper operation of your tanning system.

The current operating hours of the parts requiring maintenance can be displayed in the Presetting mode – see separate instructions 'Presettings' (order no. 1011803-..).

Please note that the device must be inspected regularly by a JK authorized representative every 12 months (from date of installation) to maintain its proper condition!

7.5.1 Acrylic panel

CAUTION!**Cosmetics may cause cracks to form on the surface!**

Over the long-term cosmetics or sunscreens cause damage (e.g. crack formation on the surface).

- Ensure that cosmetics and sunscreens are removed before tanning.

The acrylic panels for the tanning devices are produced of acrylic glass developed especially for this application. The acrylics used feature a particularly high UV permeability and resistance, as well as an easy-care, hygienic surface that is gentle on the skin.

The acrylic panels are formed to device-specific shapes in a technically complex production process. Despite state-of-the-art production know-how, the presence of minor spots, air bubbles or streaks in the acrylic panels is unavoidable. In addition, hairline cracks can occur on the acrylic panel during operation.

These occurrences are material-related and are unavoidable in processing. However, they have no significant effect on use and are therefore not accepted as defects.

Over the course of time the acrylic panel will become discolored as a result of usage and must be replaced by customer-service personnel on a regular basis.

The optional partition (only for devices with an air conditioning unit) works as a UV filter and must be replaced by customer-service personnel on a regular basis.

7.6 Maintenance plan

CAUTION!

Only use OEM spare parts of the same type! The use of other parts will void the manufacturer's warranty!

Any liability is excluded in case of damage or injury proven to be the result of the use of non-genuine spare parts.

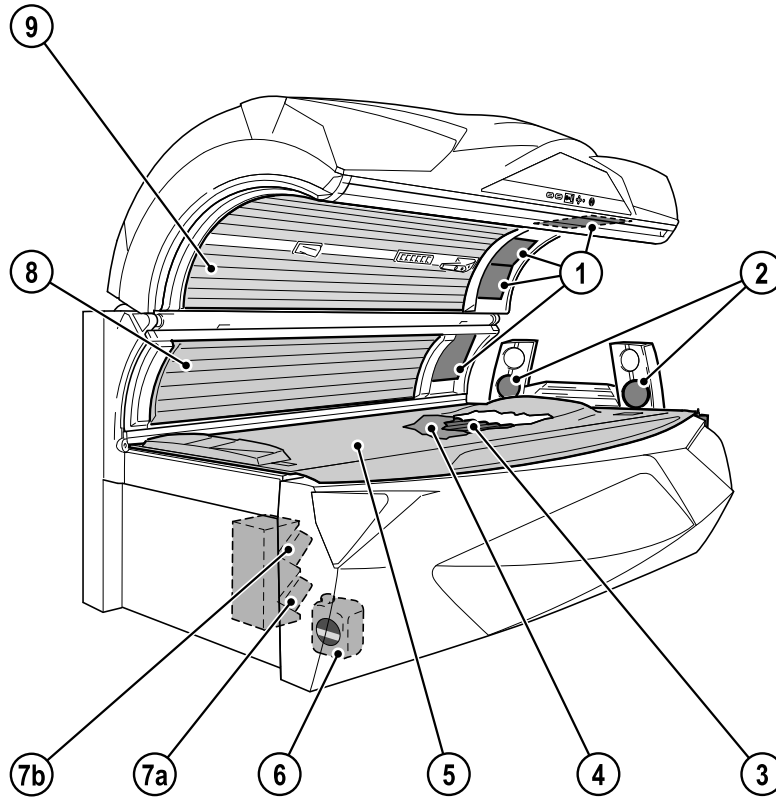

14777 / 0

Component	Interval						Activity	See page
	When necessary	300 h	500 h	1000 h	1500 h	3000 h		
6 AQUA SYSTEM	X						Replace	54, 55
7a-7b AROMA canister		X					Replace	54
1 Facial tanner UV high pressure lamps			X				Replace	45, 46
Facial tanner UV-B low pressure lamps (TYPE B)				X			Replace	45, 46
2 Shoulder tanner UV high pressure lamps			X				Replace	47
4 UV low pressure lamps, base				X			Replace	45
8 UV low pressure lamps, side section				X			Replace	45
9 UV low pressure lamps, canopy				X			Replace	46
1 Starter, canopy				X			Replace	
3 Acrylic panel					X		Replace	33
5 Partition						X	Replace	33

In addition to the maintenance plan on page 34, the following items should be checked to ensure safe operation and use of your tanning system.

	Component	Interval					Activity
		250 h / 3 months	500 h / 6 months	2500 h / 1 year	5000 h / 5 years	10000 h / 10 years	
1	Springs		X				Inspect and replace as necessary
	Springs				X		Replace
2	Bolts and fasteners of the canopy hinge mechanism	X					Inspect and replace as necessary
	Bolts and fasteners of the canopy lift mechanism	X					Inspect and replace as necessary
	Bolts and fasteners of the canopy hinge/lift mechanism					X	Replace
3	Bolts and fasteners of the base/tank hinge/lift mechanism	X					Inspect and replace as necessary
	Bolts and fasteners of the base/tank hinge/lift mechanism					X	Replace
4	Cylinders		X				Inspect and replace as necessary
	Cylinders				X		Replace
5	Chassis and associated fasteners	X					Inspect and replace as necessary
	Chassis and associated fasteners					X	Replace
6	Wiring and associated plugs / terminal connections	X					Inspect and replace as necessary
7	Acrylic panels		X				Inspect and replace as necessary
	Acrylic panels			X			Replace
8	Acrylic support(s)			X			Inspect and replace as necessary
	Acrylic support(s)				X		Replace
9	High pressure filter glass		X				Inspect and replace as necessary
	High pressure filter glass			X			Replace

7.7 Cleaning and maintenance work preparation

7.7.1 Service kit

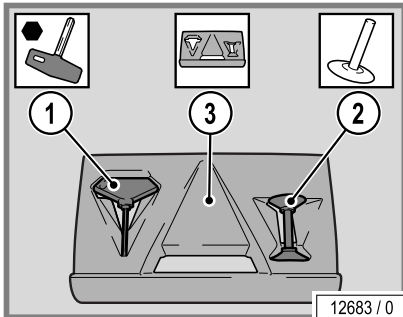

1. Allen-key
2. Suction cup for filter panels and partition
3. Scratch prevention for the entry area (canopy panel support cushion)

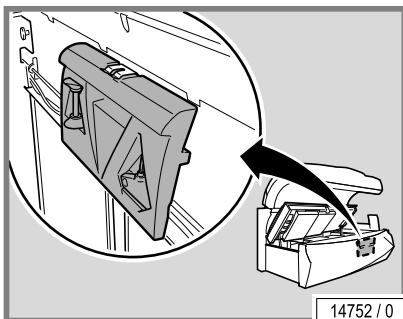

The service kit is fitted on the inside of the front panel.

- Opening the bed base: see page 40.

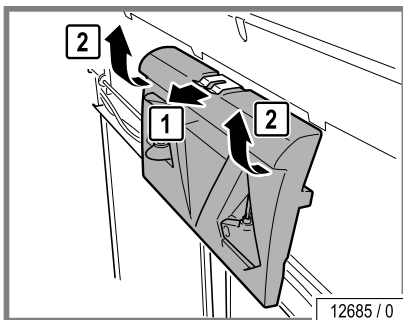

- Remove service kit from holder.

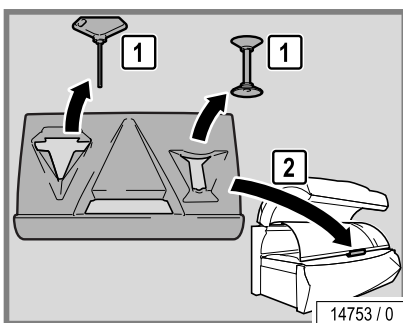

- Remove the Allen-key and suction cup.

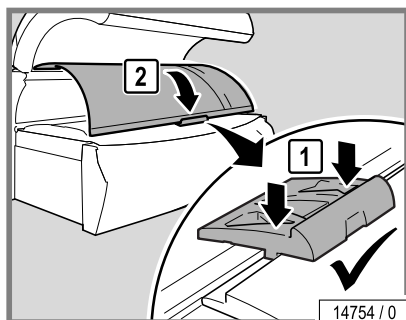

- Use the cushion to prevent scratches when opening the canopy panel.

7.7.2 Lift up the acrylic panel and remove the partition

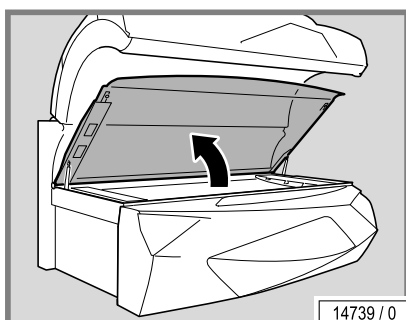

- Lift up the acrylic panel.
The acrylic panel will be held in place automatically by the acrylic supports.

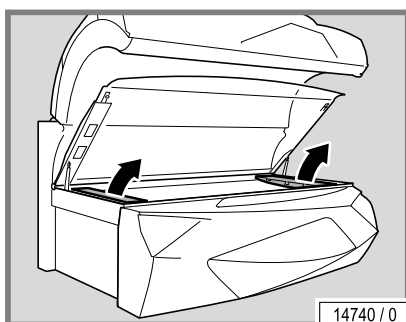

- Remove the lamp covers at the head and foot ends.

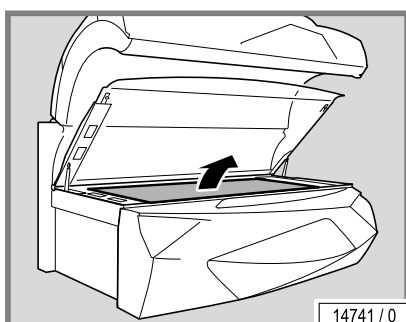

- Remove the partition.

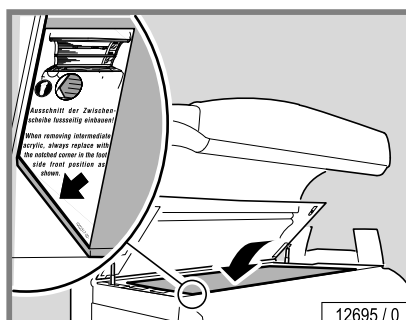

The assembly is the same process in reverse order.

When assembling the device please note:

- You must ensure that the recesses are at the foot end when you fit the partition.
- Remove fingerprints and other soiling carefully.

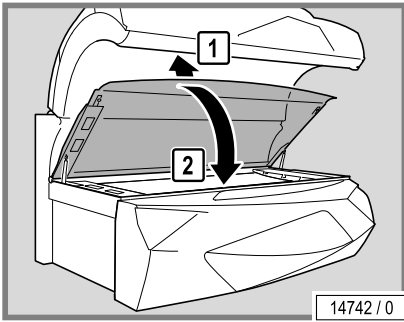

- Lift the acrylic up slightly and then close it.

7.7.3 Remove the canopy panel

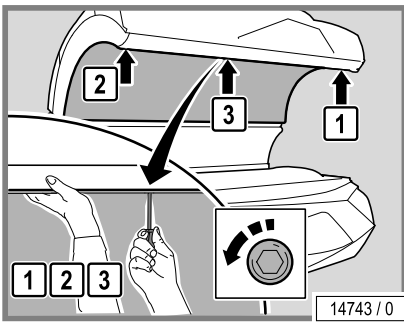

- Loosen the screws. Remove the outside screws first and then remove the screw in the middle.
- Support the canopy panel with one hand so that it does not fall down.

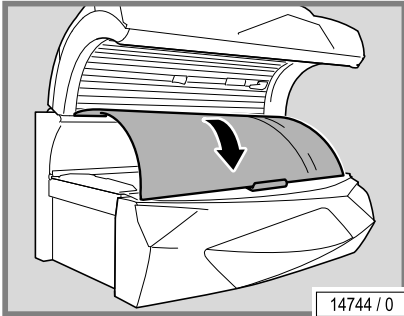

- Carefully lower the canopy panel. Use foam or something similar to protect the base acrylic, see (1).

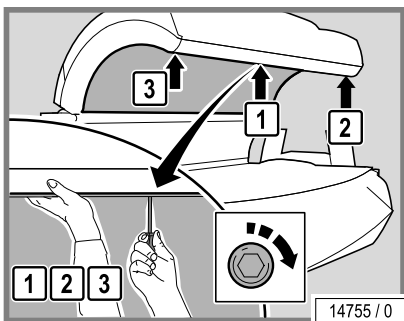

The assembly is the same process in reverse order.

When assembling the device please note:

- Support the canopy panel with one hand so that it does not fall down.
- Replace and retighten the screws. Replace the middle screw first and then the outer screws.
- Remove fingerprints and other soiling carefully.

7.7.4 Remove the side section panel

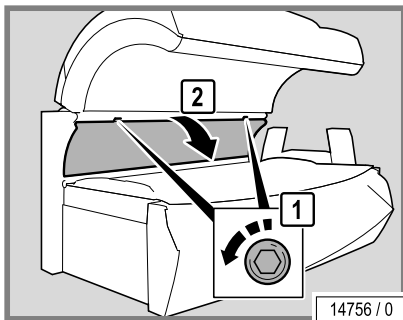

- Remove the screws.

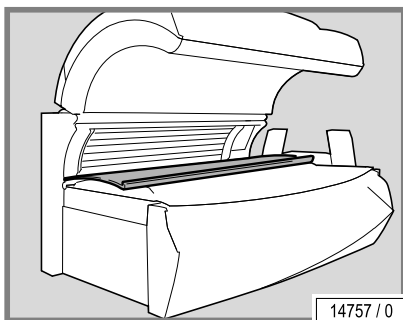

- Open the panel and lay it down carefully.

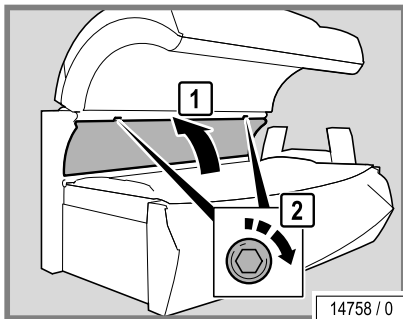

When assembling the device please note:

- Replace and retighten the screws.
- Remove fingerprints and other soiling carefully.

7.7.5 Open the bed base

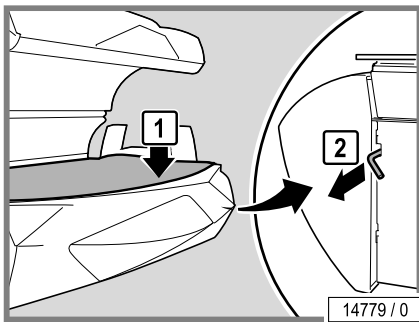

- Press the bed base gently downwards.
- Release the lock at the head end.

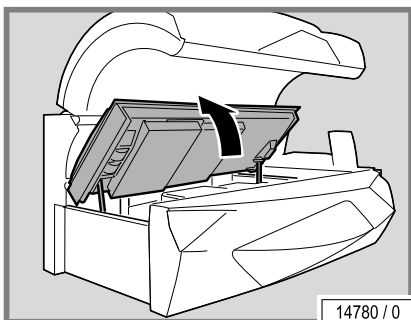

- Lift up the bed base.

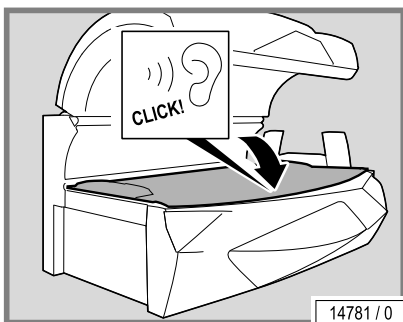

- Close the bed base. You should hear the bed base click into place.

7.8 Instructions for replacing the lamps

WARNING!



WARNING!

Danger of being burned by an over-powered lamp!

If the old chip card is left in the device, the new lamp set will be run at too high power and the user may suffer heavy burns!

- The enclosed chip card must always be used when changing the UV low pressure lamps!

The lamp's UV effect and therefore the tanning effect decrease over time. In electronically controlled low pressure lamps, this loss of effect can be compensated. The chip card is used to control the changing periods. You must adhere to the replacement intervals specified in the maintenance plan.

UV filters are used in order to control the UV radiation, e.g. the filter panels in the facial tanner. However, the filter effect decreases over the course of time. You must adhere to the replacement intervals specified in the maintenance plan.

7.8.1 Changing the chip card

The chip card belongs to the long UV low pressure lamps fitted in the canopy, the side panels and the device's base.

The chip card is located in the 'Part support control'.

- Opening the bed base: see page 40.

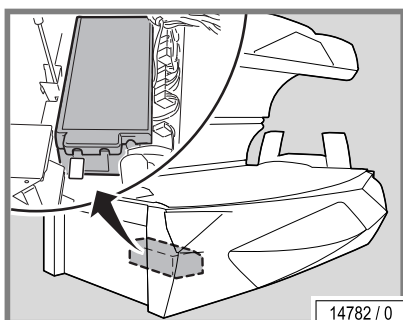

14782 / 0

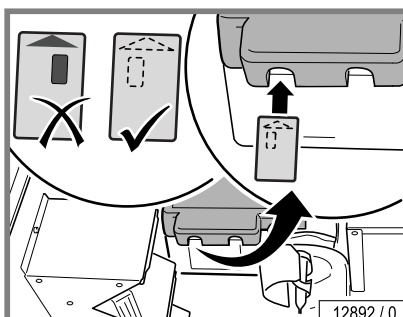

12892 / 0

- Remove the chip card belonging to the old lamp set.
- Insert the new chip card with the text facing downwards and the arrow pointing forwards.
- Close the bed base. You should hear the bed base click into place.

7.8.2 Low pressure lamps

- Replace faulty UV low pressure lamps immediately. Install replacement lamps to the outer edges of the tanning area.
- Always replace the entire set of lamps after the specified operating time.
- Turn 90° and carefully remove from the socket.

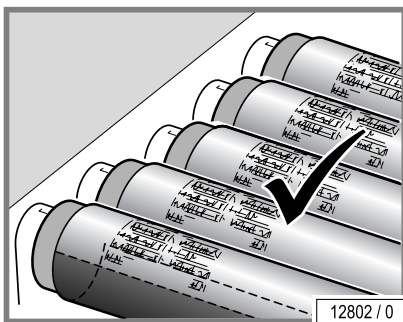
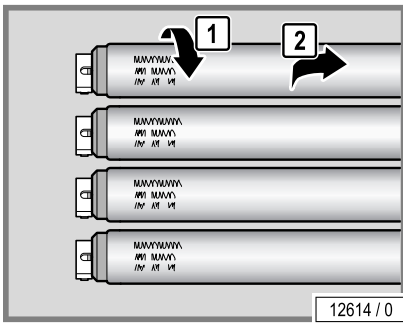

- UV low pressure lamps possess a reflector which directs the light outwards. The lamps must be mounted in such a way that the rear side of the reflector is located on the device side.

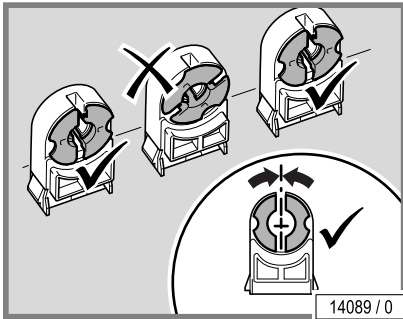

- Push the pins vertically into the socket from above.

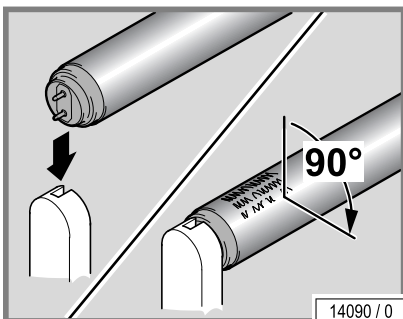

- Turn the lamp 90°. The lettering must be oriented towards the outside (i.e. towards the tanning room or towards the user).

7.8.3 Starter

- Replace faulty starters immediately.

You can recognize a faulty starter by the blackened ends of the lamps or when the lamps can no longer be started.

Operating a lamp with a faulty starter significantly shortens its service life. The lamp loses power and may begin to flicker under certain circumstances.

The starters are located in either one of the two lamp sockets or are visible when the lamps are removed.

- Turn 90° and carefully remove from the socket.

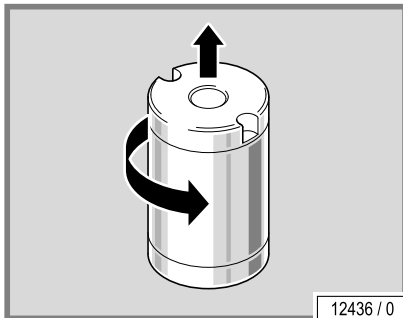

12436 / 0

7.8.4 High pressure lamps and filter panels

UV high pressure lamps are used in the facial tanner and the shoulder tanner.

CAUTION!



Danger of overheating will exist if the wrong UV high pressure lamps are used!

The danger of overheating will exist if the wrong UV high pressure lamps are fitted in the shoulder tanner. The device might be damaged.

- Never interchange the UV high pressure lamps used in the facial tanner with those used in the shoulder tanner!

WARNING!



WARNING!

Fire hazard due to overheated lamps!

Non-approved high pressure lamps can explode. Hot lamp components can set other parts on fire. People can be killed or severely injured due to smoke inhalation and fire.

- Only fit the high pressure lamps specified by the manufacturer.
- Clean the inside of the device regularly. Dust particles are flammable!

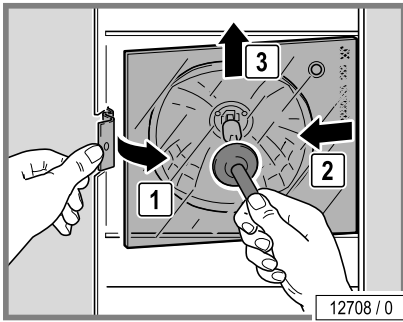

- Release the clamping holder.
- Lift the filter panel, pull it out of the guide and remove it.

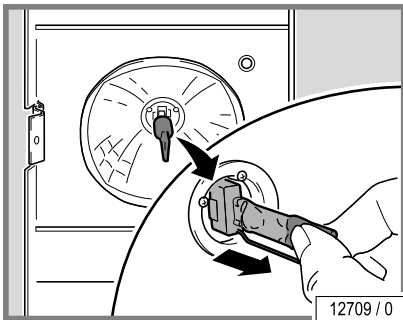

- Unplug the UV lamps.
- Clean the reflector.

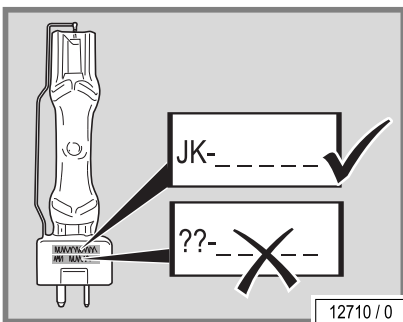

- Only utilize original UV lamps.

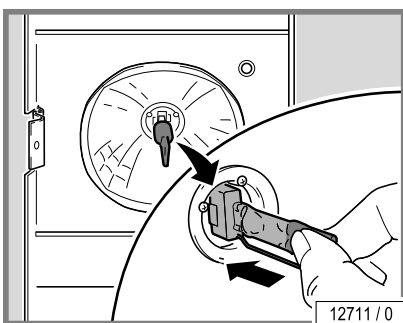

- Only touch new lamps in the handling zone.

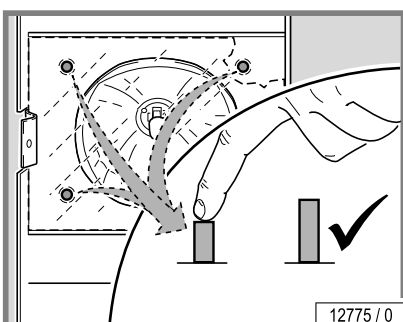

- Test the safety switch to ensure that it works.
The safety switch ensures that the device switches off in the event of a faulty filter panel or when a filter panel is missing.
- Press the button.
If the button springs back automatically then it is functional.
- Replace the filter panel.

7.9 Cleaning or replacing UV lamps in the base

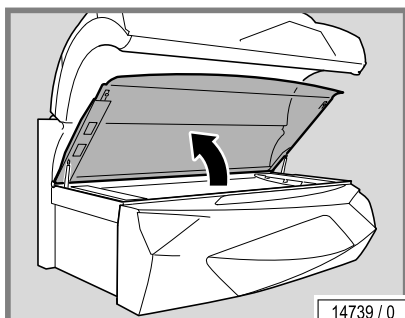

- Lift up the acrylic panel and then remove the lamp covers and the partition: see page 36.

Replacing lamps: see page 42.

Changing the chip card: see page 41.

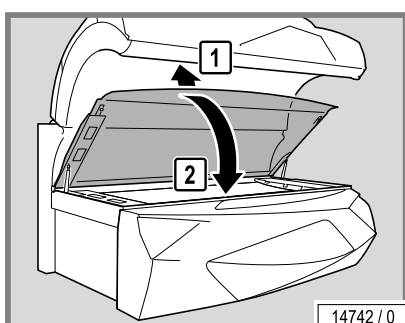

The assembly is the same process in reverse order.

When assembling the device please note:

- You must ensure that the recesses are at the foot end when you fit the partition.
- Lift the acrylic up slightly and then close it.

7.10 Cleaning or replacing the UV lamps in the side section

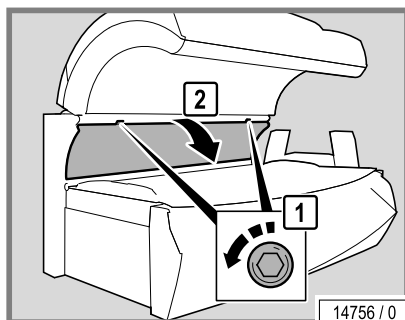

- Removing the side section panel: see page 39.

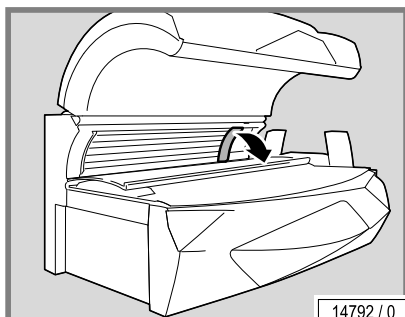

- Remove the lamp cover.

Replacing lamps:

UV low pressure lamps: see page 42.

UV high pressure lamps and filter panels: see page 43.

Changing the chip card: see page 41.

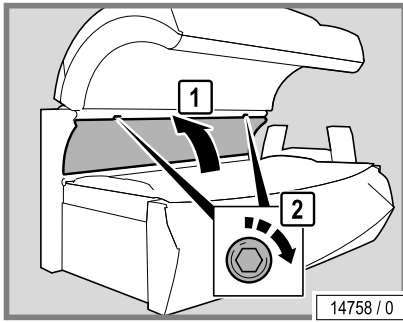

When assembling the device please note:

- Refit and retighten the screws.

7.11 Cleaning or replacing UV lamps and filter panels in the canopy

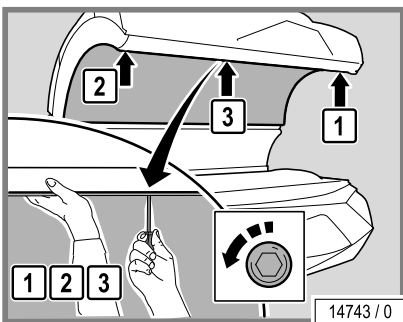

- Removing the canopy panel: see page 38.

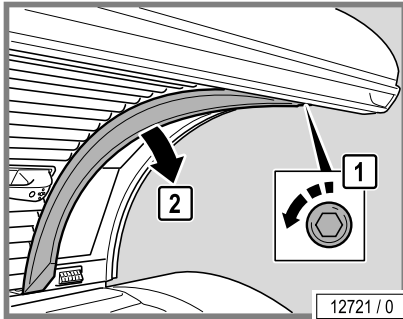

- Remove the screws and then remove the lamp cover.

The following components listed in the maintenance plan are fitted in the canopy:

- UV low pressure lamps: see page 42.
- Facial tanner UV high pressure lamps and filter panels: see page 43.
- Facial tanner filter panels
- Facial tanner UV low pressure lamps and the associated starters

Changing the chip card: see page 41.

The facial tanner's UV low pressure lamps must be removed first so that the UV high pressure lamps and the filter panels can be changed.

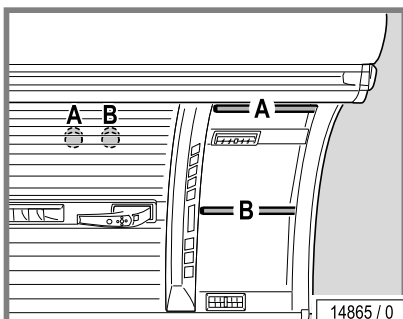

- Remove the lamps.

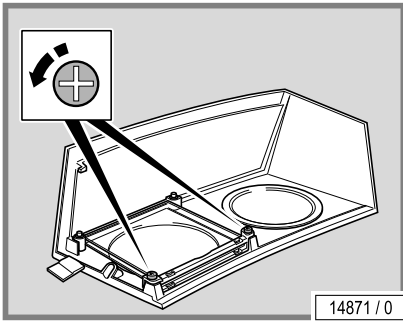

Each of the high pressure lamps in the shoulder tanner is fitted with 2 different filter panels. The two filter panels are secured in place inside the housing.

- Remove the screws.

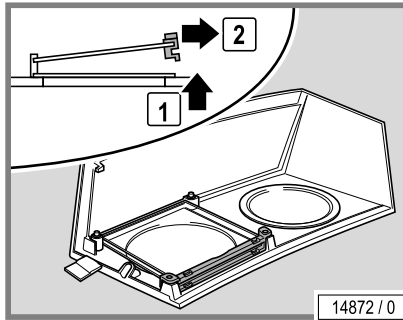

- Use the suction cup to lift the upper filter panel.
- Pull out the holder.

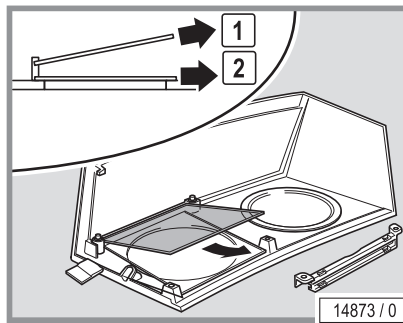

- Use the suction cup to remove the two filter panels.

CAUTION!



Do not interchange filter panels!

The shoulder tanner is fitted with different filter panels.
a) Ultra Performance 912 (blue), order no. 1500635-..
b) Non-coated, order no. 1500160-..

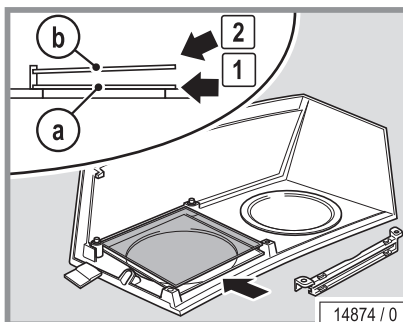

- Fit the new filter panels in the correct sequence.

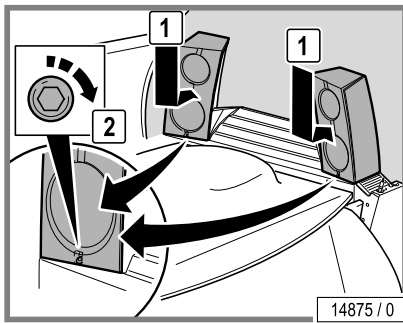

The assembly is the same process in reverse order.

7.13 Cleaning the filters in the base

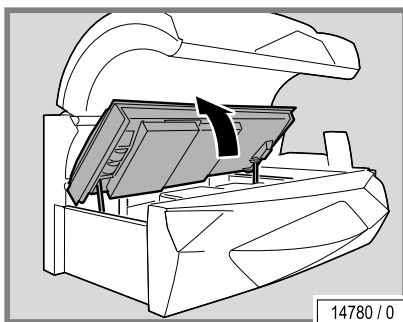

- Opening the bed base: see page 40.

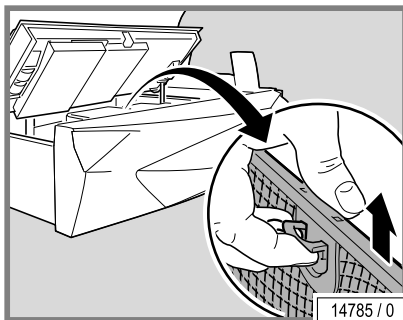

- Remove the filters.

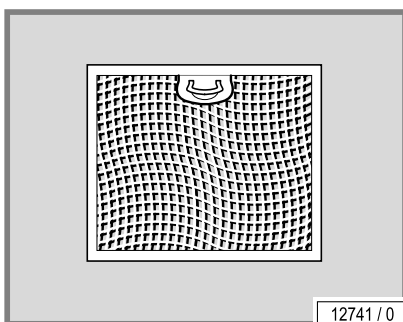

- Cleaning the filters when wet or dry.

Dry cleaning: Vacuum cleaner (depending on the degree of soiling)
Wet cleaning: Use water and detergent or put in a dish-washer

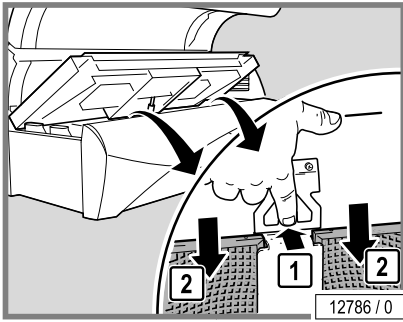

CAUTION!



The device may be damaged by moisture!
The cleaned filters must be dry before they are replaced.

- Reinstall the cleaned and dried filters.
- Close the bed base. You should hear the bed base click into place.

7.14 Cleaning the canopy filter mats

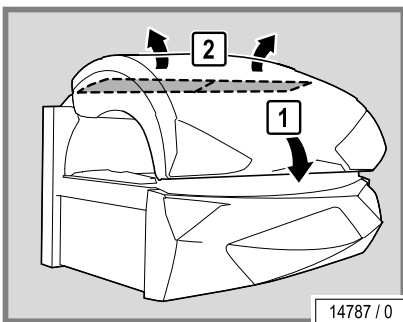

- Remove the filter mats fitted at the back of the canopy.

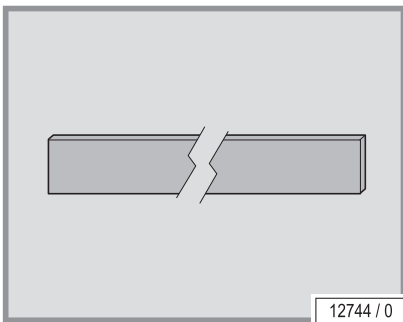

- Dry or moist clean the filter mats or replace with new ones.
Dry cleaning: Vacuum cleaner (depending on the degree of soiling)
Moist cleaning: Water and detergent
- **Do not clean in the dish-washer!**

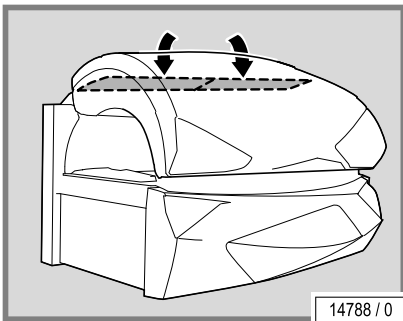

CAUTION!



The device may be damaged by moisture!
The cleaned filters must be dry before they are replaced.

- Reinstall the cleaned and dried filter mats.

7.15 Air conditioning: Empty the condensation tank and clean the filter

CAUTION!



Damage to the device through soiled filters and cooling fins!

Regularly check the filter grill and cooling fins on the air conditioning system and clean if necessary.

We recommend using the specially manufactured fin comb, art-no. 15720470, to clean the cooling fins.

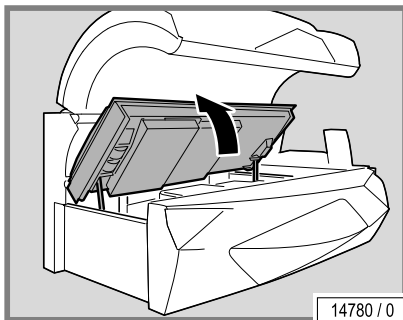

- Opening the bed base: see page 40.

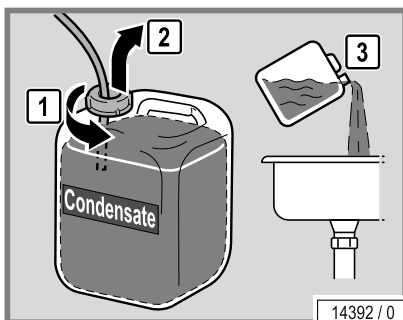

- Bring the condensation tank forwards.
- Disconnect the hose on the condensation tank.
- Empty the condensation tank.

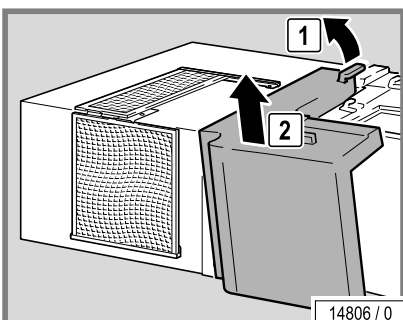

- Remove the cover.

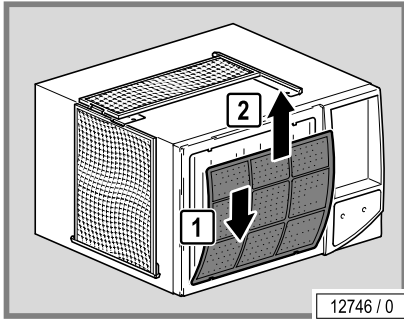

- Remove the filter from the holder.

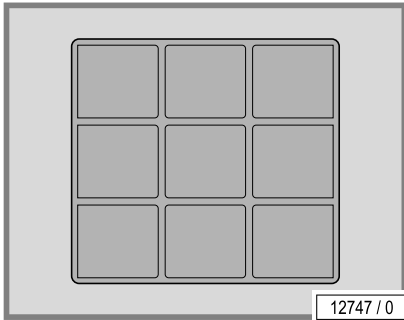

- Cleaning the filter when moist or dry.
- Dry cleaning: Vacuum cleaner (depending on the degree of soiling)
 Moist cleaning: Water and detergent
- **Do not clean in the dish-washer!**

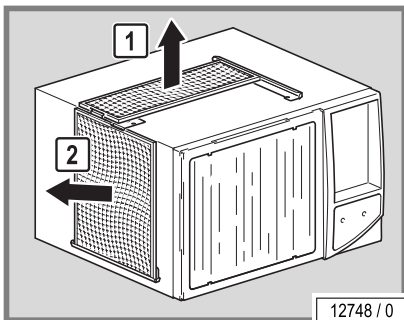

- Remove the filters from the holder.

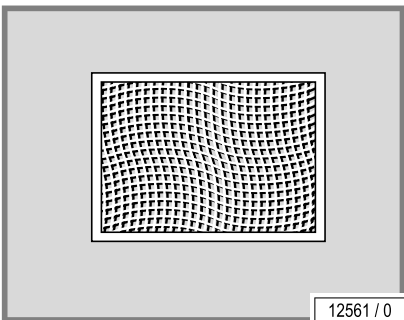

- Cleaning the filters when wet or dry.
- Dry cleaning: Vacuum cleaner (depending on the degree of soiling)
 Wet cleaning: Use water and detergent or put in a dish-washer

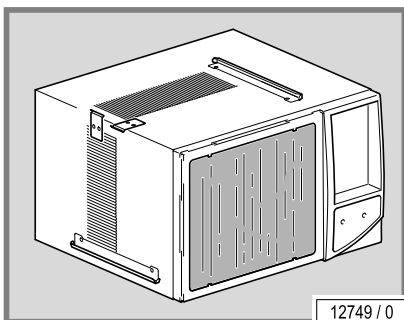

- Use a fin comb to clean the air conditioning's dirty cooling fins.



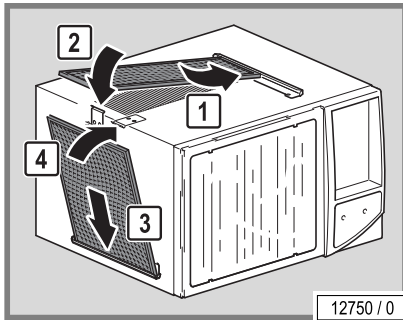

CAUTION!



The device may be damaged by moisture!

The cleaned filters must be dry before they are replaced.

- Reinstall the cleaned and dried filters.
- Ensure that the filters are correctly positioned in the holder.

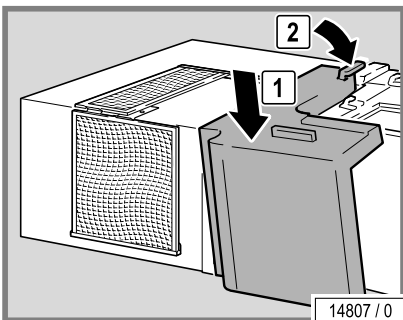
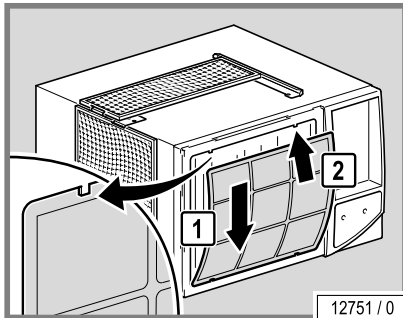

- Attach the cover.



- Connect the condensation tank to the hose.
- Refit the condensation tank.
- Close the bed base. You should hear the bed base click into place.

7.16 AQUA / AROMA SYSTEM maintenance

The AQUA SYSTEM function sprays a fine mist of AQUA SOLAR WITH SKIN+ ADDITIVE into the interior of the device for body cooling (see 'AQUA SYSTEM PRODUCT INFORMATION', order no. 1011201-..).



WARNING!



WARNING!

Customer health hazard!

Water that has been contaminated with bacteria can cause skin rashes and other allergic reactions in device users.

- Therefore you must never fill the AQUA SYSTEM canister with tap water or other liquids.
- Only replace the AQUA SYSTEM canister with a genuine canister.
- Do not add any liquid that remains in the old canister to the new canister!
- Ensure that the maximum temperature specified is not exceeded during transport and storage.
- Note the expiration date on the canister.

This AQUA / AROMA SYSTEM also includes the 'RELAX' fragrance, which is distributed through the head nozzles. Another fragrance called 'CABIN' is distributed within the cubicle.

7.16.1 Changing the AROMA canister

- Opening the bed base: see page 40.

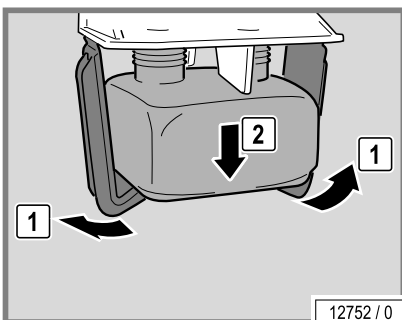
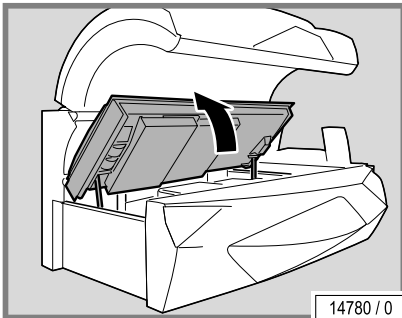

- Remove the AROMA canister.

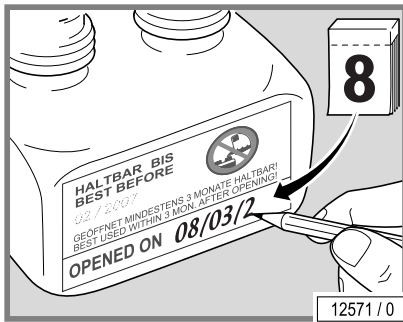

- Unscrew the lid on the new canister.
- Write the date on the canister.

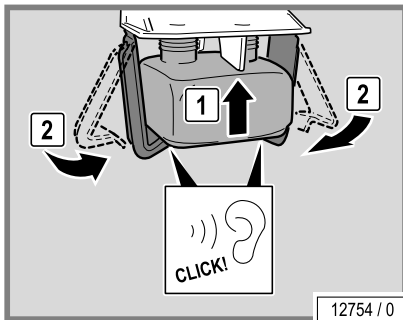

- Fit the canister in the holder.
- Close the bed base. You should hear the bed base click into place.

7.16.2 Replacing the AQUA SYSTEM canister

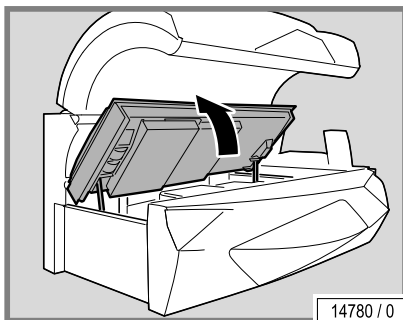

- Opening the bed base: see page 40.

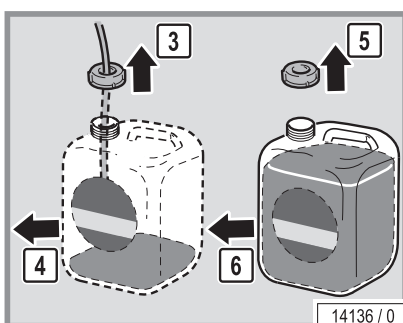

- Remove the canister.
- Unscrew the lid on the new canister.
- Remove the lid with the hose from the old canister.

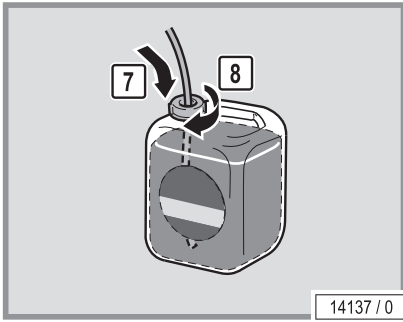

- Screw the lid with the hose onto the new canister.
- Push the hose well down so that it touches the bottom of the canister.
- Put the canister back in the device.
- Close the bed base. You should hear the bed base click into place.

Venting



NOTE:

Ventilate after changing the canister by switching over to preset mode and then select Function 231 (see 'Presettings', order no. 1011803-..).

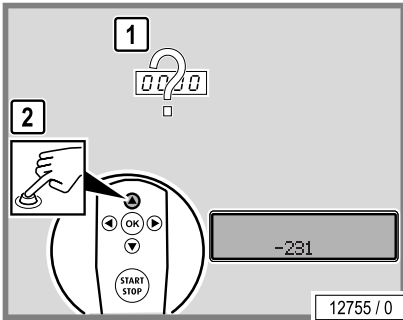

- Press the START/STOP button and top navigation arrow simultaneously.

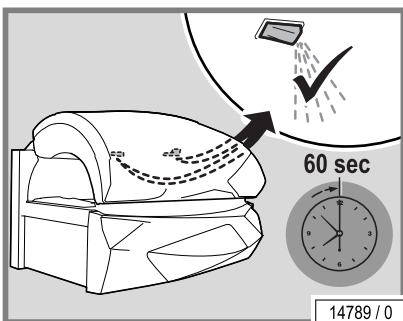
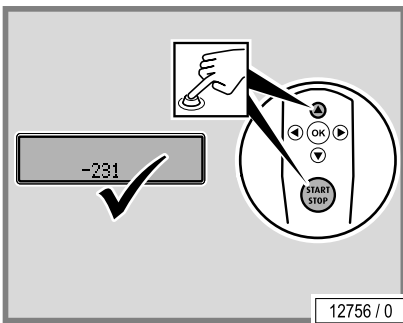

- Close the canopy.
- The system will now be ventilated for 1 minute. AQUA SYSTEM liquid will be released from the nozzles during this period.
- Test the AQUA SYSTEM function afterwards. Repeat the ventilation process if it does not work.

8 Technical data

8.1 Power rating, electrical specifications and noise level

Prestige 1000 Intelligent Performance		
Nominal power consumption:	16,700 W	
Rated frequency:	60 Hz	
Rated voltage:	230 V 3 phase	230 V 1 phase
Rated fuses:	70 amp 3-pole	110 amp 2-pole
Noise level at 1 m distance from the device (without exhaust air):	62.9 dB(A)	
Noise level in device:	<81 dB(A)	
Load on the acrylic panel:	max. 300 lb / 135 kg	
Weight:	approx. 1,358 lb / 616 kg	

8.2 Dimensions

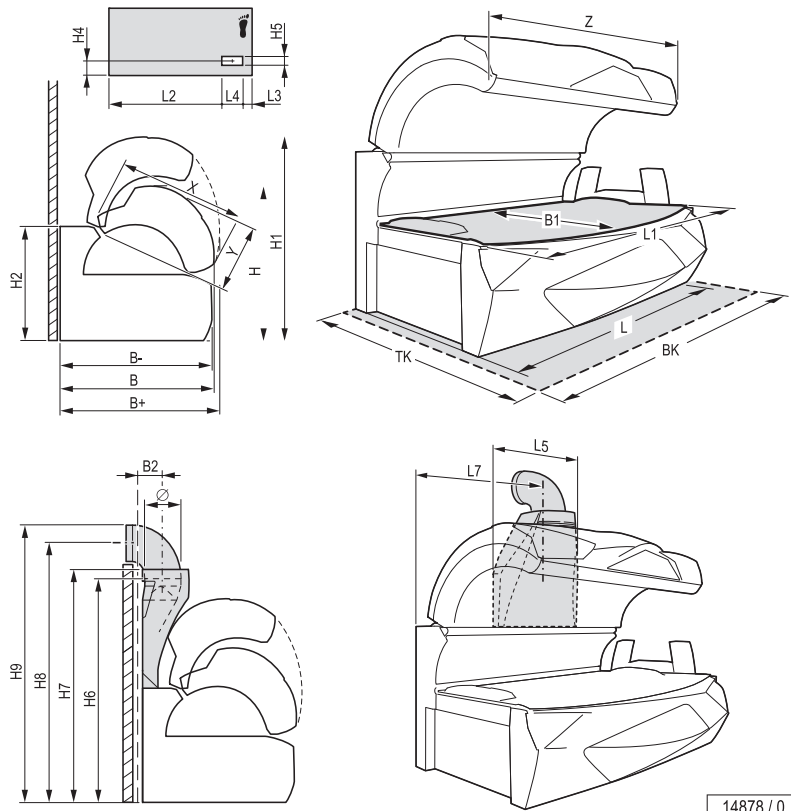

B+ =	60 13/16 in	1,545 mm	H =	58 11/16 in	1,491 mm
B =	59 14/16 in	1,521 mm	H1 =	76 15/16 in	1,955 mm
B- =	59 11/16 in	1,516 mm	H2 =	43 9/16 in	1,106 mm
B1 =	37 1/2 in	953 mm	H4 =	17 11/16 in	450 mm
B2 =	8 1/16 in	205 mm	H5 =	2 3/16 in	56 mm
L =	93 11/16 in	2,380 mm	H6 =	74 in	1,879 mm
L1 =	86 5/8 in	2,200 mm	H7 =	78 13/16 in	2,002 mm
L2 =	69 1/8 in	1,756 mm	H8 =	87 3/16 in	2,215 mm
L3 =	9 1/4 in	235 mm	H9 =	92 15/16 in	2,360 mm
L4 =	9 9/16 in	243 mm	Ø =	11 13/16 in	300 mm
L5 =	34 1/8 in	867 mm	BK =	98 7/16 in	2,500 mm
L7 =	44 1/8 in	1,120 mm	TK =	90 9/16 in	2,300 mm
X =	50 4/16 in	1,277 mm			
Y =	28 1/16 in	712 mm			
Z =	88 3/16 in	2,240 mm			

8.3 Lamp configuration

CAUTION!



The use of other UV lamps and filter panels voids the operating license!

8.3.1 Prestige 1000 Intelligent Performance

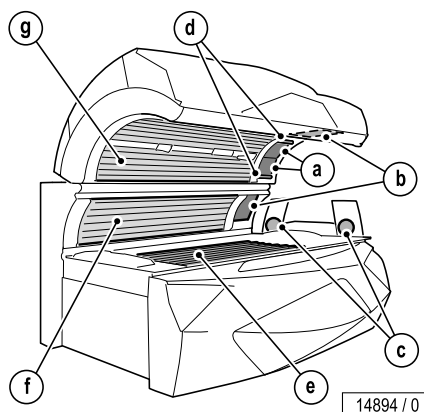

Installed lamps

	Number	Description	Length	Power	Control	Order no.
a)	2	UV high pressure lamps Ergoline ULTRA C12645		520 W	420 W / 360 W / 260 W / 0 W	12645-..
	2	Filter panels Ultra Performance 412				1000121-..
b)	2	UV high pressure lamps Ergoline ULTRA C12645		520 W	420 W / 360 W / 260 W / 0 W	12645-..
	2	Filter panels Ultra Performance 412				1001526-..
c)	2	UV high pressure lamps Ergoline ULTRA S1500384		250 W	250 W / 0 W	1500384-..
	2	Filter panels Ultra Performance 912 (blue)				1500635-..
	2	Filter panels uncoated				1500160-..
d)	2	UV low pressure lamps Ergoline VHP B-POWER	12 3/16 in 0.31 m	8 W	8 W	1507918-..
	2	Starter S10 (4-65 W)				10047-..
e)	18	UV low pressure lamps Ergoline VHP10 INTELLIGENT PERFORMANCE 200 W	71 in 1.80 m	200 W	80-200 W	1507905-..
f)	8	UV low pressure lamps Ergoline VHP10 INTELLIGENT PERFORMANCE 200 W	71 in 1.80 m	200 W	80-200 W	1507905-..
g)	22	UV low pressure lamps Ergoline VHP10 INTELLIGENT PERFORMANCE 200 W	71 in 1.80 m	200 W	80-200 W	1507905-..

8.4 Spare parts and accessories

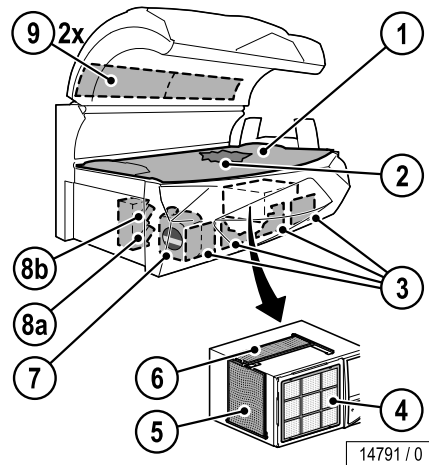

Number	Description	Order no.
1	1 Acrylic panel	735377-..
2	1 Partition Acrylic	1500339-..
3	4 Filter	52104-..
4	1 Filter	-
5	1 Filter	51937-..
6	1 Filter	55567-..
7	1 AQUA SYSTEM, 1.59 gal (6 l)	1010506-..
8	1 AROMA, 3.38 fl oz (100 ml)	
a)	CABIN	701358-..
b)	RELAX	701357-..
9	2 Filter	843150-..
	1 Protective goggles	84592-..
	1 MP3 cable	4630911001-..
	1 Allen-key	83828-..
	1 Chipcard of lamp set	1507921-..

9 JK-Products, Inc. – Limited Warranty

JK-Products, Inc. warrants its products to be free from defects in materials and workmanship under intended normal use as described in the unit's Operation and Instruction Manual, for a period of three (3) years from date of sale.

This Limited Warranty applies only to the original purchaser of the equipment through JK-Products, Inc. or its authorized dealer or distributor, and is not transferable.

Global Service USA obligations under this warranty are limited to repair or replacement of any defective part without charge for that part to the original purchaser, with the following exceptions:

A Fluorescent lamps are warranted against defects for a period of thirty (30) days from date of sale.

B Only parts obtained through JK-Products, Inc., its authorized dealers or distributors may be used. Transportation costs for parts shipped to the consumer and the return of defective parts to Global Service USA are not included.

C Labor will be furnished without charge for ninety (90) days from date of purchase only. All labor and related charges must be authorized by Global Service USA prior to start of repairs, and must coincide with Global Service USA established rates and time allotment policy.

D Acrylic: Refer to Manufacturer's Acrylic Warranty Policy.

It is imperative that the original customer completes and returns the enclosed warranty card within 10 days after purchase to insure valid registration and coverage for potential claims.

If the warranty card is not registered, proof of purchase from JK-Products, Inc. or its authorized dealer or distributor will be required prior to any consideration on warranty claims. This could result in service delays.

This warranty is extended to the individual or legal entity, whose name appears on the warranty registration card filed with Global Service USA, or whose name appears on the original sale document and may not be transferred to any other individual or legal entity.

This warranty does not apply to any failure of the product, or any parts of the product due to alterations, modifications, misuse, abuse, accident, improper maintenance, improper installation, acts of God or if the serial number on the product has been removed, altered or defaced. Adequate packaging must be used for returned goods to prevent freight damage.

There are no warranties which extend beyond the description on the face hereof. There is no express or implied warranty of fitness of merchantability.

The remedies provided in this limited warranty are the exclusive remedies provided to the purchaser by Global Service USA and are provided in substitution of all other remedies. Consequential and incidental damages are excluded.

No person, firm or corporation is authorized to obligate JK-Products, Inc. for any liability in connection with the sale or use of these goods.

JK Products & Services, Inc. makes no guarantees on income, return on investment, market conditions, performance, etc. with any undertaking using its products and services. Past performance is not indicative of future results.

9.1 Limited Acrylic Warranty

JK Products, Inc. warrants its acrylic sheets to be free from defects in material and workmanship, under intended normal use, for a period of one (1) year from date of sale of the tanning bed. Due to the tanning lotions, cosmetics, disinfectant and improper cleaners used on tanning surfaces that cannot be controlled by JK Products, Inc., after the first thirty (30) days of warranty period acrylic will be subject to a prorated cost to the consumer.

JK Products, Inc. obligations do not include transportation charges on replacement acrylic.

JK Products, Inc. assumes no liability for the cost of removing defective sheets or installing replacement sheets, or for damage to persons or property.

To make a claim, contact an authorized dealer or distributor of JK-Products, Inc. or Global Service USA with the model number, the serial number, and the date of purchase of the bed in which the acrylic will be used.

There are no warranties which extend beyond the description on the face hereof. There is no express or implied warranty of fitness or merchantability.

The remedies provided in this limited warranty are the exclusive remedies provided to the purchaser by Global Service USA and are provided in substitution of all other remedies. Consequential and incidental damages are excluded.

JK Products & Services, Inc.
#1 Walter Kratz Drive
Jonesboro, AR 72401
Phone: 800-445-0624 (toll-free)
Fax: 870-935-9046
e-mail: support@jkamerica.com
<http://support.jkamerica.com>

9.2 Warranty Claims

9.2.1 Policy & Procedures

1. When to file a Warranty Claim:

In the event that your tanning system is not functioning properly under intended normal use as described in the unit's Operation and Instruction Manual, you may then have established cause to file a Warranty Claim.



NOTE:

Both the tanning system and legal registered owner must meet the criteria established under JK Products, Inc. Limited Warranty as described in this manual before any Warranty Claim will be considered.

2. Where to call to place a Warranty Claim:

JK-Products, Inc. is supported nationwide by an extensive dealer/distributor network through whom the majority of our units are sold. These dealers/distributors are required by contract to stock sufficient parts to meet the various warranty and nonwarranty needs of their customers.

Therefore, in order for you to properly file a Warranty Claim, you must locate the name and phone number of the dealer/distributor through whom you purchased your unit. Normally this information can be easily located either on your paid invoice or other proof of purchase documentation that you received when taking delivery of the unit.

Next, notify the dealer/distributor of the serial number, model number and date unit was purchased. This will initiate the Warranty Claim process.

Upon determination of the problem, your dealer/distributor can then supply you with the part(s) and proper instructions to return your unit to working order.

Each dealer/distributor has their own internal procedure for handling Warranty Claims and credits.

**NOTE:**

JK-Products, Inc., the manufacturer, does not involve itself in the direct handling of a Warranty Claim except where mitigating circumstances apply and where required by law.

**NOTE:**

If part returned to Global Service USA proves to be operational and not defective, or if product code numbers on part do not correspond with individual unit date on file with Global Service USA, then a 30% restocking fee will be charged in addition to the retail purchase price of part.

Acknowledgment of the Agreement is not required for acceptance of the foregoing stipulations.

9.2.2 Labor Warranty Claim/Credit Procedures

Global Service USA furnishes labor without charge for a period of 90 days from date of purchase. All labor and related charges must be authorized by Global Service USA prior to start of repairs, and must coincide with Global Service USA established rates and time allotment policy.

Please contact our Service Department for authorization and billing procedures.

9.3 Limited Lifetime Warranty

Global Service USA warrants specific individual components of the tanning system against defects in materials and workmanship for the life of the product. Coverage is limited to units purchased after November 1, 1994.

This warranty is restricted to the following components only:

- Steel Back Panels
- Structural Steel Frame Components
- Exterior Steel Body.



NOTE:

Components are warranted on an individual basis and not as they may effect the complete product.

Warranty coverage does not include cosmetic abnormalities such as scratches, nicks, dents, rust, oxidation of paint or other cosmetic changes that do not interfere with the designed function of the unit.

This warranty does not include failure of the product due to alteration, modifications, misuse, abuse, improper maintenance, improper installation or repair.

This warranty is not transferable and is only applicable to the original purchaser named on a completed and registered warranty record at JK-Products, Inc. headquarters.

JK Products, Inc. obligations do not include transportation charged on the shipping of new components to the customer or on the return of defective components of the manufacturer. All freight charges must be paid by the customer.

There are no warranties which extend beyond the description on the face hereof. There is no express or implied warranty of fitness or merchantability.

The remedies provided in this limited warranty are the exclusive remedies provided to the purchaser by Global Service USA and are provided in substitution of all other remedies. Consequential and incidental damages are excluded.



NOTE:

Any misuse, abuse, modification, alteration, improper maintenance, improper installation, etc. of this product or its intended use will subject said party to direct responsibility and liabilities for any and all consequences resulting from such action. Furthermore, such actions will void all warranties and may relieve Global Service USA of any liabilities relating to said product.

Warranty Registration

Please complete the back of the card below and return to JK Products and Services.

Ergoline

ANGEL

BEAUTY

soltron

DASH

ets.com



IMPORTANT! Your warranty card must be completed within ten (10) business days from the date of receipt for your equipment to be covered by the manufacturer's warranty.

✂ Detach Here ✂

0071305201

JK PRODUCTS & SERVICES
1 WALTER KRATZ DR
JONESBORO AR 72401-9977

POSTAGE WILL BE PAID BY ADDRESSEE

BUSINESS REPLY MAIL
FIRST-CLASS MAIL PERMIT NO. 295 JONESBORO AR



NO POSTAGE
NECESSARY
IF MAILED
IN THE
UNITED STATES

Limited Warranty

JK Products and Services warrants its products to be free from defects in materials and workmanship under intended normal use as described in the Operation/Instruction Manual. Refer to the Operation/Instruction Manual for specific details.

This Limited Warranty applies only to the original purchaser of the equipment through JK Products and Services or its authorized distributors or dealers and may not be transferred.

JK Products & Services' obligations under this warranty are limited to the repair (or replacement) of the defective part without charge to the original purchaser with the following exceptions:

- I. Lamps (fluorescent or high pressure) are warranted against defects for a period of thirty (30) days from the date of sale.
- II. Only parts obtained through JK Products & Services, its authorized distributors or dealers may be used.
- III. Replacement parts provided may be either new or reconditioned at the discretion of JK Products & Services.
- IV. Transportation cost for parts shipped to the customer and the return of defective parts are not included.
- V. Returned parts must be received in a condition such that its functional status at the time of its removal may be ascertained. Adequate packing must be used when returning any part to JK Products & Services. Warranty coverage may be denied for any claim where the part is damaged as a result of poor or inadequate packaging.
- VI. Labor will be furnished without charge for a period of ninety (90) days from the date of sale to the original purchaser at the original location of installation. All labor related charges must be authorized by JK Products & Services prior to repair and performed by a technician authorized by JK Products & Services. Rates and charges for repairs must comply with JK Products & Services allotment policy.
- VII. Lifetime warranty applies only to main frame super structure. Refer to the Operation/Instruction manual for specific details.

The original purchaser must complete and return the attached warranty card within ten (10) business days of receipt of equipment for coverage of potential claims under this warranty.

If no warranty card is received, proof of purchase from JK Products & Services, or an authorized distributor or dealer must be provided for a claim to be considered. JK Products & Services reserves the right to deny claims where proof of purchase has been provided but no warranty card was received.

This warranty does not apply to any failure of the product or any parts of the product due to alterations, use of third party or non-OEM parts, modifications, misuse, abuse, accident, improper maintenance, improper installation, or acts of God. This warranty also does not apply if:

- I. The serial number on the product has been removed, altered, or defaced.
- II. The serialized components of the unit do not match with other serialized components in records maintained by JK Products & Services.
- III. The serial number or serialized components have been altered with the intent to defraud.

There are no warranties which extend beyond the description on the face hereof. There is no express or implied warranty of fitness or merchantability. The remedies provided in this limited warranty are the exclusive remedies provided to the original purchaser by JK Products & Services and are provided in substitution of all other remedies. Consequential and incidental damages are excluded.

No person, firm, or corporation is authorized to obligate JK Products & Services for any liability in connection with the sale or use of these goods.

JK Products & Services • One Walter Kratz Drive • Jonesboro, AR 72401
870.935.1130 • 800.643.0086

⌂ Detach Here ⌂

Studio/Salon Name: _____
 Contact Name: _____
 Street Address: _____
 City: _____ State: _____ Zip: _____
 Telephone: (____) _____ Start-Up Date: _____
 JK Distributor/Affiliate: _____

Indicate below that each of the task below have been completed/that the aspects of the tanning system are in working order:

Lamps:	Features/Options:	Training:
<input type="checkbox"/> Body	<input type="checkbox"/> Skin Sensor	<input type="checkbox"/> Basic Operation
<input type="checkbox"/> Base	<input type="checkbox"/> Air Conditioning	<input type="checkbox"/> Accessing Lamps
<input type="checkbox"/> Canopy	<input type="checkbox"/> Aqua Mist	<input type="checkbox"/> Location/Access
<input type="checkbox"/> Facial Lamps	<input type="checkbox"/> Aroma	Filters
<input type="checkbox"/> Shoulder Tanner	<input type="checkbox"/> Audio System	<input type="checkbox"/> Explanation of
<input type="checkbox"/> Decor		Features
	Missing Components:	Settings/Adjustments:
	<input type="checkbox"/> Manuals	<input type="checkbox"/> Audio
	<input type="checkbox"/> Hardware	<input type="checkbox"/> Springs
	<input type="checkbox"/> Accessories	<input type="checkbox"/> Network

By signing below, you confirm that the listed equipment was delivered to the stated address, installed, and was received in full and satisfactory working order.

Signature, JK Dist./Affiliate _____ Date _____
 Signature, Studio/Salon Representative _____ Date _____

TANNING SYSTEM Affix Serialized Label Here	ACCESSORY 1 Affix Serialized Label Here
ACCESSORY 2 Affix Serialized Label Here	

Please indicate [by marking an X] on the applicable illustration any damage to the tanning system

Comments: _____

10 Appendix

10.1 Signs and stickers on the device

Signs which warn of danger areas are attached to the device. The signs shown below are examples. Ensure that the instruction signs are always clearly recognizable and easily legible. Any missing instruction signs or stickers must be replaced.

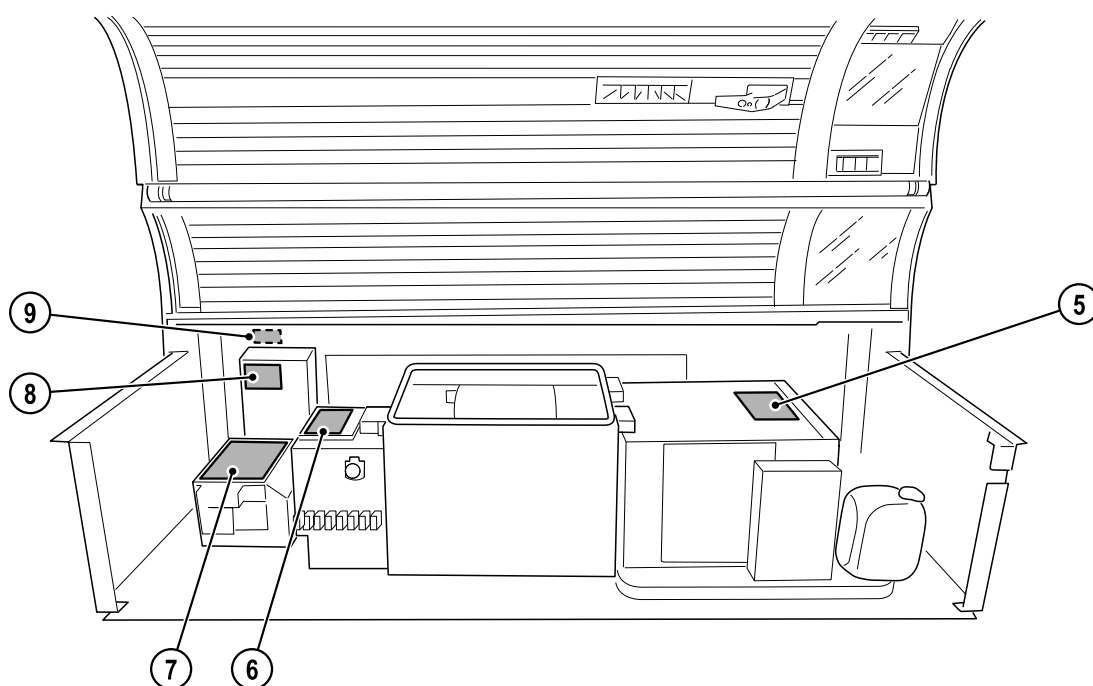
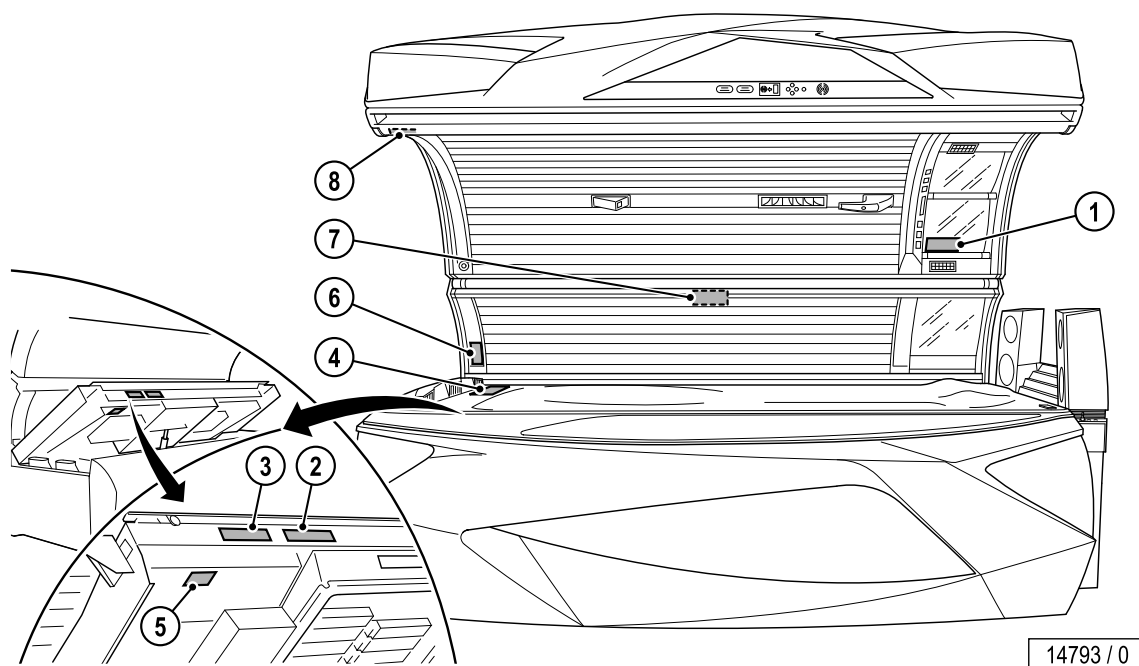

1: Name plate

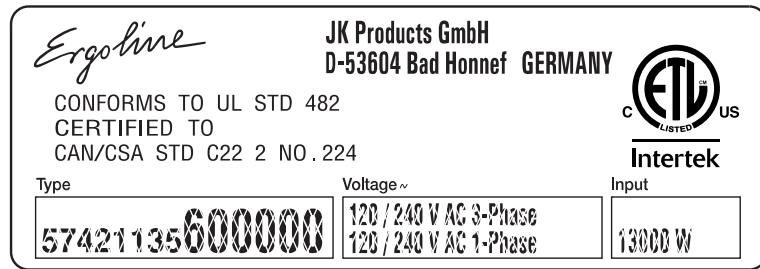

14126 / 1

The name plate is attached to the interior side of the canopy. It contains important information for identifying the device (e. g. the serial number = Serial-No.) and the conformity mark.

2: Module plate

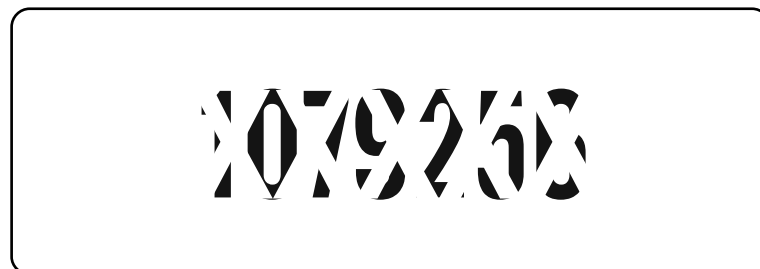

14434 / 0

3: OEM Parts sticker (801138-..)



13513 / 0

The sticker is mounted on the bottom edge at the front of the bed base.

4: Exposure label

Skin Type	Recommended Exposure Schedule				
	Week 1 1st - 3rd Treatments	Week 2 4th - 6th Treatments	Week 3 7th - 10th Treatments	Week 4 11th - 15th Treatments	Weekly Subsequent Treatments
I - Sensitive	Not Advised	Not Advised	Not Advised	Not Advised	Not Advised
II - Fair	2 Min.	4 Min.	6 Min.	8 Min.	10 Min.
III - Average	2 Min.	4 Min.	6 Min.	8 Min.	10 Min.
IV - Brown	2 Min.	6 Min.	8 Min.	10 Min.	10 Min.
V - Dark Brown	2 Min.	6 Min.	8 Min.	10 Min.	10 Min.

DANGER ULTRAVIOLET RADIATION
Follow instructions. Avoid over-exposure as with natural sunlight. Over-exposure can cause eye and skin injury and allergic reactions. Repeated exposure may cause premature aging of the skin and skin cancer.
MAXIMUM TANNING TIME: 10 MINUTES

<p>WEAR PROTECTIVE EYEWEAR! Failure to do so may result in severe burns or long term injury to the eyes.</p> <p>Certain medications or cosmetics may increase your sensitivity to the ultraviolet radiation. Consult a physician before using sunlamps if you are using medication, have a history of skin problems or believe yourself to be especially sensitive to sunlight. If you do not tan in the sun, you are unlikely to tan from the use of this product.</p>	<p>This unit utilizes UV lamps. Replace only with Ergoline INTELLIGENT PERFORMANCE 200 W VHP 10, Ergoline VHP B-POWER (low pressure/ facial-tanner), Ergoline ULTRA 520 W C12645 (high pressure/ facial-tanner) and Ergoline ULTRA 250 W S1500384 (high pressure/ shoulder tanner) or recognized equivalents. To obtain recommended exposure at a minimum distance of 1/2" (13 mm) measured with a standard ruler, lie on acrylic surface of lounge and lower canopy. Canopy will stop at the correct distance from lounge acrylic surface.</p> <p>Warning: The use of any other position may result in overexposure!</p>
--	--

<p>Tanning can begin on a regular basis. An appearance of tanning normally appears after a few exposures and maximizes after four (4) weeks of exposure following the recommended exposure schedule for skin type. In order to provide for maintenance of a tan a maximum of two (2) weekly 10 minute sessions is recommended from the fifth week onward. Do not tan more than once in a 24 hour period.</p>	<p>Use protective eyewear, super sunnies, when ever unit is energized. Read and follow instruction booklet before using this product. To avoid electrical shock during maintenance disconnect power from unit. This product is in conformity with performance standards for sunlamp products under 21CFR 1040, FDA.</p> <p style="text-align: right;">Part No: 1014403-00</p>
---	---

14897 / 1

5: Air conditioning sticker (1002243-..)

ACHTUNG! Hier oben!
Falls Klimagerät gekippt, vor Inbetriebnahme 8 Stunden in Normalstellung stehen lassen, wegen Rücklauf der Kühlflüssigkeit

ATTENTION! This side up!
In case air condition unit was toppled over, let it 8 hours in home position before initiation, because of the return of the refrigerant.

GEFAHR
Bei geöffnetem Gerät nicht spannungsfrei!

DANGER
Voltage is not switched off, when sunbed is opened.

Regelmäßige Sichtprüfung!
Regular visual check!
Contrôle visuel régulier!

Gefahr von Geräteschäden!
Risk of damage to equipment!
Risque de détérioration de l'appareil!

Abdeckung entfernen!
Remove cover!
Éliminer la couverture!

Filtermatten reinigen!
Renew filter mats!
Nettoyer les mats filtrants!

Kühlrippen reinigen!
Clean cooling fins!
Nettoyer les barres de refroidissement!

Kondensatbehälter entleeren!
Empty condensation container!
Vidanger le réservoir à condensation!

1002243-01

13435 / 0

The sticker is mounted on the air conditioning.

6: Ballast support warning sticker (1003399-..)

The sticker is mounted on the power unit support.

7: Controller connections sticker (843147-..)

The sticker is mounted on the controller support.

8: USA mains connection sticker

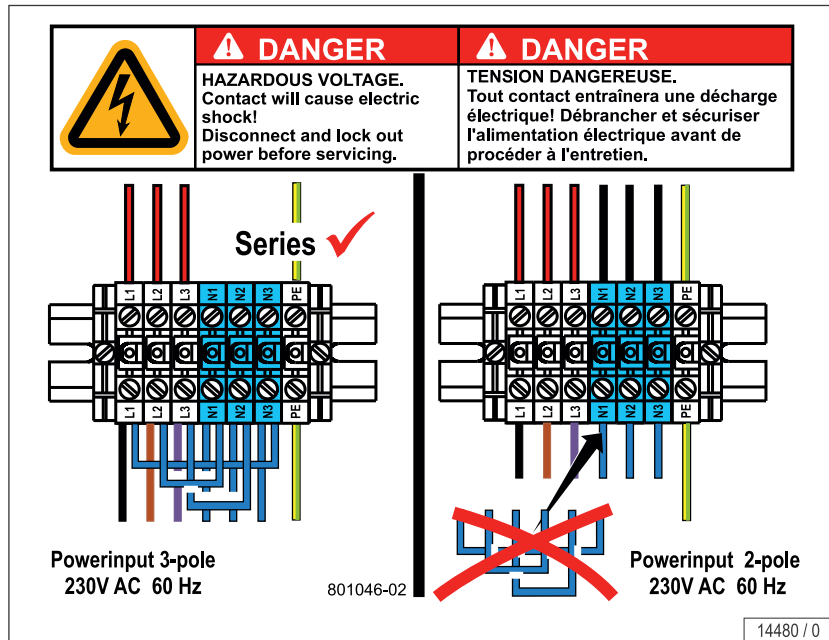

The sticker is mounted on the rear panel at the left.

9: Canada warning sticker (801371-..)

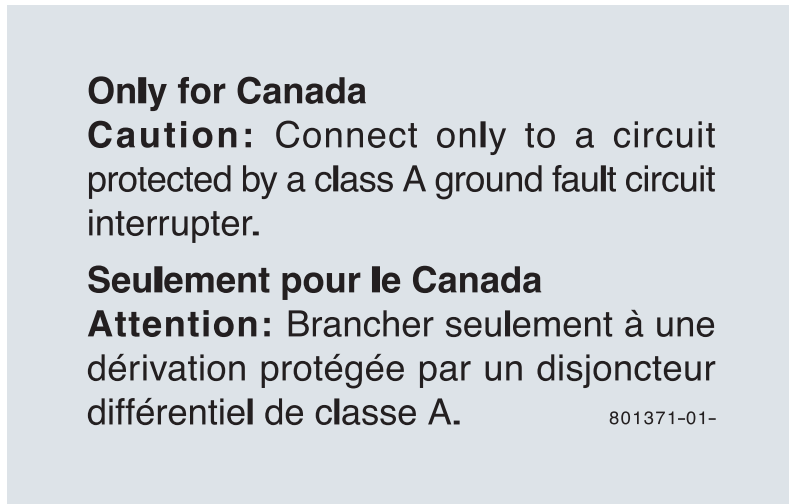

13514 / 0

The sticker is mounted on the rear panel.

11 Index

A

Accessories.....	17, 60
Acrylic glass (maintenance)	30
Acrylic panel (product information).....	33
Acrylic panel, load.....	57
Adolescents	12, 18
AQUA / AROMA SYSTEM maintenance.....	54
Assembly	13

C

Changing the AROMA canister	54
Changing the chip card	41
Changing the starter	43
Cleaning.....	28, 30
Air conditioning.....	51
Air conditioning filter.....	51
Filter	49
Filter mats.....	50
Lamps, filter panels	31
Cleaning / replacing the UV lamps	
Base	45
Facial tanner.....	46
Shoulder tanner.....	47
Side section.....	45
Cleaning intervals	31
Cleaning overview.....	31
Cleaning the filter	49, 50
Connect MP3 player	27
Contact lenses	19
Copy protection.....	14

D

Definitions	7
Description	16
Device description.....	16
Dimensions	58
Disinfection	30
Disposal	14

E

Electric shock.....	9
Electrical specifications	57
Electrician	7
Empty the condensation tank....	51
Equipment.....	15
Exhaust air ventilation.....	13
Export.....	13
Eye damage.....	18

F

Facial tanner	
Cleaning/replacing.....	46
Fault codes	29
Faults	29
Filter panels	43
Cleaning/replacing...45, 46, 47	
Foreseeable misuse.....	12
Functions	22, 24

G

Glasses	19
Guidelines.....	13

H

High pressure lamps, danger of fire!.....	43
--	----

I

Injury	9
Installed lamps	59
Instruction signs	14
Intended use	12
Itching	18

L

Lamp configuration	59
Lamps	12
Lift up the acrylic panel	37
Light sensitivity.....	18

M		S	
Maintenance.....	28, 30, 32	Safety notices.....	9
Maintenance overview.....	33	Scope of delivery.....	15
Make-up	19	Service kit.....	36
Medications	18	Setup.....	13
MP3 music	14	Sickness.....	18
O		Skin types.....	6
Open the bed base.....	40	Spare parts.....	33, 60
Operating overview	20	Staff.....	7
Operating structure	22	Staff training	13
Operator	7	Start tanning.....	26
Operator's obligations	12	Start-up settings	26
P		Sunburn.....	18
Plastic surfaces (maintenance)	30	T	
Play rights	14	Tanning times.....	6
Power rating	57	Technical Service.....	2
Product information	12	Transport.....	13
Protective measures when performing maintenance work..	28	U	
Q		UV lamps.....	59
Qualified staff	7	V	
R		Ventilation	13
Recycling.....	14	W	
Remove the canopy panel.....	38	Warning signs, description	8
Remove the side section panel	39		
Replace the UV low pressure lamps.....	42		
Replacing the AQUA SYSTEM canister.....	55		
Replacing the lamps.....	41		
Risk of injury.....	18		

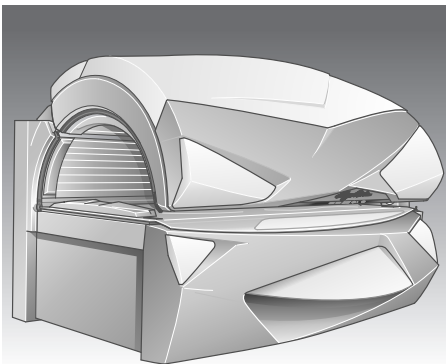

Ergoline

PRESTIGE 1000 INTELLIGENT
PERFORMANCE

JK-Products & Services, Inc.

1 Walter Kratz Drive
Jonesboro, AR 72401
Phone: 800.643.0086 (Toll-free)
Fax: 870.935.3618
Website: www.sunergoline.com
E-Mail: ergoline@sunergoline.com