

PRESTIGE SERIES



■ OPERATING INSTRUCTIONS

Ergoline

Ergoline PRESTIGE

1002509-01B- / us / 09.2007

OPERATING INSTRUCTIONS



PRESTIGE 990 Dynamic Power Temptronic
PRESTIGE 990 Dynamic Power Temptronic Plus
VHP 10

PRESTIGE 1100 Extreme Power Temptronic Plus
VHP 10

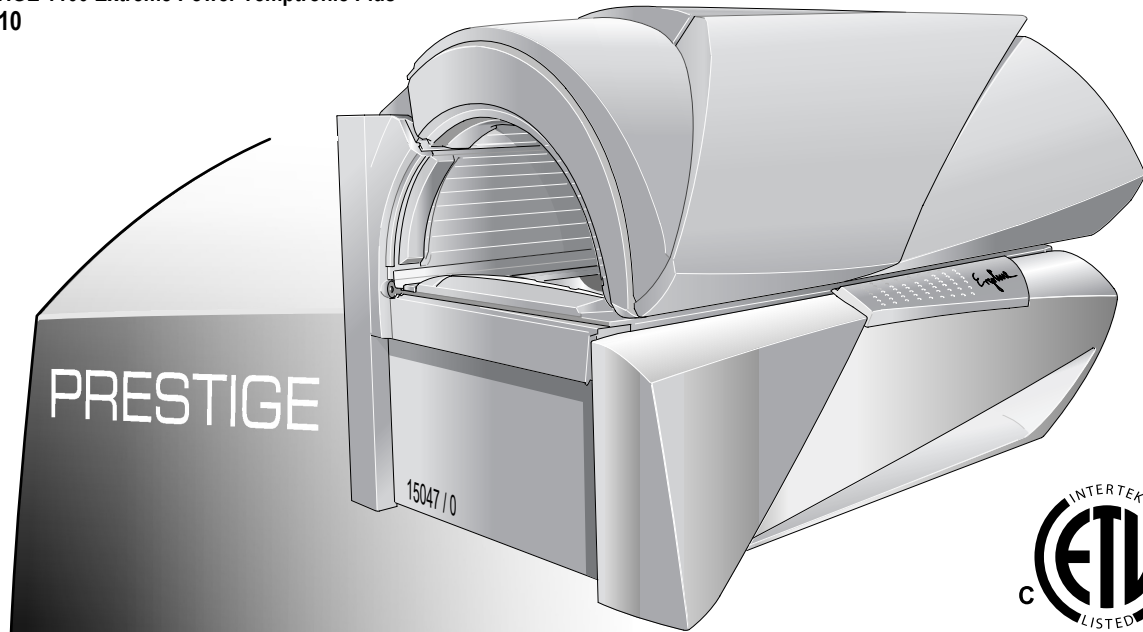

Identify your tanning device3

Table of Contents8

Identify your tanning device

For contact with Customer Services, please write down the device number of your tanning device.

- PRESTIGE 990 DYNAMIC POWER TEMPTRONIC
- PRESTIGE 990 DYNAMIC POWER TEMPTRONIC PLUS
- PRESTIGE 1100 EXTREME POWER TEMPTRONIC PLUS

--	--	--	--	--	--	--	--

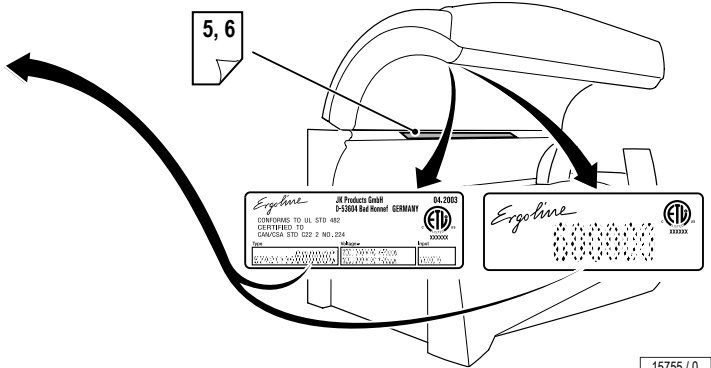

15755 / 0

Global Service USA
 A Div of JK Products & Services, Inc.
 #1 Walter Kratz Drive
 Jonesboro, AR 72401



(800) 445-0624
 (870) 935-9046

e-mail: support@jkamerica.com
<http://support.jkamerica.com>

Skin types

Skin types

For the recommended exposure schedule (see pages 5 and 6).

Skin type I (Sensitive):

Invariably gets sunburn, accepts little natural sunlight and does not tan.

Skin type II (Fair):

This is the individual that usually burns easily and severely, tans minimally or lightly and peels.

Skin type III (Average):

Often referred to as "Average" complexion, burns moderately and tans about average.

Skin type IV (Brown):

This individual burns minimally, tans easily and above average with each exposure.

Skin type V (Dark Brown):

This individual rarely burns, tans easily and substantially.

Tanning times – PRESTIGE 990 DYNAMIC POWER

DANGER ULTRAVIOLET RADIATION		Recommended Exposure Schedule					
Follow instructions. Avoid over-exposure as with natural sunlight. Over-exposure can cause eye and skin injury and allergic reactions. Repeated exposure may cause premature aging of the skin and skin cancer.		Week 1 1st - 3rd Treatments	Week 2 4th - 6th Treatments	Week 3 7th - 10th Treatments	Week 4 11th - 15th Treatments	Weekly Subsequent Treatments	
Skin Type		NOT ADVISED	NOT ADVISED	NOT ADVISED	NOT ADVISED	NOT ADVISED	
I - Sensitive		2 Min.	4 Min.	6 Min.	8 Min.	10 Min.	
II - Fair		2 Min.	4 Min.	6 Min.	8 Min.	10 Min.	
III - Average		2 Min.	4 Min.	6 Min.	8 Min.	10 Min.	
IV - Brown		2 Min.	4 Min.	6 Min.	8 Min.	10 Min.	
V - Dark Brown		2 Min.	4 Min.	6 Min.	8 Min.	10 Min.	

Maximum Tanning Time is 10 Minutes

WEAR PROTECTIVE EYEWEAR! Failure to do so may result in severe burns or long term injury to the eyes.	This unit utilizes UVA lamps. Replace only with Ergoline DYNAMIC POWER 200W, Ergoline ULTRA 520W C12645 (high pressure/ facial-tanner) and Ergoline ULTRA 250W S1500384 (high pressure/ shoulder-tanner) or recognized equivalents. To obtain recommended exposure at a minimum distance of 1/2" (13mm) measured with a standard ruler, lie on acrylic surface of lounge and lower canopy. Canopy will stop at the correct distance from lounge acrylic surface.
Certain medications or cosmetics may increase your sensitivity to the ultraviolet radiation. Consult a physician before using sunlamps if you are using medication, have a history of skin problems or believe yourself to be especially sensitive to sunlight. If you do not tan in the sun, you are unlikely to tan from the use of this product.	Warning: The use of any other position may result in overexposure!

Tanning can begin on a regular basis. An appearance of tanning normally appears after a few exposures and maximizes after four (4) weeks of exposure following the recommended exposure schedule for skin type. In order to provide for maintenance of a tan a maximum of two (2) weekly 10 minute sessions is recommended from the fifth week onward.	Use protective eyewear (Part No. Schneider 2255 Red or recognized equivalents) when equipment is on. Read and follow instruction booklet before using this product. To avoid electrical shock during maintenance disconnect power from unit.
Do not tan more than once in a 24 hour period.	Part No: 1004453-00-



Note:
Description of skin types see Page 4.

16050 / 0

“This product is in conformity with performance standards for sunlamp products under CFR21 Part 1040.”

Tanning times – PRESTIGE 1100 EXTREME POWER

DANGER ULTRAVIOLET RADIATION					
Follow instructions. Avoid over-exposure as with natural sunlight. Over-exposure can cause eye and skin injury and allergic reactions. Repeated exposure may cause premature aging of the skin and skin cancer.					
Maximum Tanning Time is 10 Minutes					
	Recommended Exposure Schedule				
Skin Type	Week 1 1st - 3rd Treatments	Week 2 4th - 6th Treatments	Week 3 7th - 10th Treatments	Week 4 11th - 15th Treatments	Weekly Subsequent Treatments
I - Sensitive	NOT ADVISED	NOT ADVISED	NOT ADVISED	NOT ADVISED	NOT ADVISED
II - Fair	2 Min.	4 Min.	6 Min.	8 Min.	10 Min.
III - Average	2 Min.	4 Min.	6 Min.	8 Min.	10 Min.
IV - Brown	2 Min.	6 Min.	8 Min.	10 Min.	10 Min.
V - Dark Brown	2 Min.	6 Min.	8 Min.	10 Min.	10 Min.

<p>WEAR PROTECTIVE EYEWEAR! Failure to do so may result in severe burns or long term injury to the eyes.</p> <p>Certain medications or cosmetics may increase your sensitivity to the ultraviolet radiation. Consult a physician before using sunlamps if you are using medication, have a history of skin problems or believe yourself to be especially sensitive to sunlight. If you do not tan in the sun, you are unlikely to tan from the use of this product.</p>	<p>This unit utilizes UVA lamps. Replace only with Ergoline EXTREME POWER 200W, Ergoline MAX TAN 15W EXTREME POWER (low pressure/facial-tanner), Ergoline ULTRA 520W C12645 (high pressure/ facial-tanner) and Ergoline ULTRA 250W S1500384 (high pressure/ shoulder-tanner) or recognized equivalents. To obtain recommended exposure at a minimum distance of 1/2" (13mm) measured with a standard ruler, lie on acrylic surface of lounge and lower canopy. Canopy will stop at the correct distance from lounge acrylic surface.</p> <p>Warning: The use of any other position may result in overexposure!</p>
--	---

<p>Tanning can begin on a regular basis. An appearance of tanning normally appears after a few exposures and maximizes after four (4) weeks of exposure following the recommended exposure schedule for skin type. In order to provide for maintenance of a tan a maximum of two (2) weekly 10 minute sessions is recommended from the fifth week onward.</p> <p>Do not tan more than once in a 24 hour period.</p>	<p>Use protective eyewear (Part No. Schmerler 2255 Red or recognized equivalents) when equipment is on. Read and follow instruction booklet before using this product. To avoid electrical shock during maintenance disconnect power from unit.</p> <p style="text-align: right;">Part No: 1003578-02-</p>
--	--



Note:
Description of skin types see Page 4.

15756 / 2

“This product is in conformity with performance standards for sunlamp products under CFR21 Part 1040.”

Dear Customer,

The Ergoline device you have purchased is a technically advanced and powerful product. Your device was manufactured with the greatest care and precision. It went through numerous quality and safety checks in order to guarantee trouble-free, safe operation. Nonetheless, you can also make a significant contribution to your long-term satisfaction with your device. Following the tips and instructions in the instruction manual will ensure you enjoyment and pleasure with your device.

If you have any questions, we are always available to answer them.¹⁾

Yours sincerely

JK-Products, Inc.

- Read and observe the information in this instruction manual. This will enable you to prevent accidents and provide you with a reliable device ready for use.
- Always observe current legal and other regulations and legal requirements as well as the applicable environmental protection regulations.



Note:

We reserve the right to make technical changes to the illustrations and specifications in this instruction manual. Reprinting and reproduction, in whole or in part, of this manual is only permitted with our previous written approval and with the source specified.

1) ☎ (800) 643-0086

Table of Contents

Skin types	4	Operating instructions	23
Tanning times – PRESTIGE 990 DYNAMIC POWER	5	Device description	24
Tanning times – PRESTIGE 1100 EXTREME POWER	6	Accessories	25
Important safety notes and information	10	Operation at a glance	26
Safety notices	10	Operation buttons and display unit	27
Intended use	11	Operation / Navigation	28
Obligations of the salon operator	11	Operating structure	29
Instructions pertaining to a risk of fire, electric shock, or injury	12	Tanning	30
Instructions pertaining to a risk of damage to the machine	14	Interrupt or end tanning session	31
Meaning of symbols	15	Running time of accent lights	32
Guidelines	18	Regulating facial tanners	33
Export	18	Switching the shoulder tanner off and on	36
Accessories	18	Temptronic – Adjust coolness	38
Product information	18	Regulating body cooling	40
Environmental protection information	20	Regulating facial cooling	42
Maintenance and care	20	Activating AQUA MIST Impulse	44
Cleaning	21	Switching AQUA MIST comfort program on and off	45
Use the sunbed – but use it properly!	22	Switching AQUA MIST head nozzle off and on	47
		Switching AQUA MIST body nozzle off and on	49
		Switching AROMA off and on	51

Table of Contents

Voice Guide	53	Cleaning/replacing accent lights, canopy	99
Selecting audio system	55	Cleaning/replacing accent lights, front panel	101
Adjusting volume	56	Cleaning filters, sunbed base	104
Changing music track or studio music channel	58	Cleaning/replacing filter mats, canopy	106
Connecting an MP3 player	60	Temptronic: Emptying condensate tank, cleaning/replacing the filter mats, cleaning the cooling fins	107
Technical Data	62	Temptronic plus: Emptying condensate tank, cleaning/replacing the filter mats, cleaning the cooling fins	110
Maintenance instructions	65	Replacing AROMA container	113
Power Off device and secure against being switched on again.	65	AQUA MIST SYSTEM: Replacing canister.	115
Maintenance: overview	66	Index	117
Cleaning intervals	67	JK-Products, Inc. – Limited Warranty	119
Maintenance intervals, installed lamps and order numbers.	69	Appendix	123
Relamping / maintenance instructions.	79	Timer operation – see manual “Intellitran Remote Timer”, Order no. 801129-..	
Inserting the chip card for the new set of lamps	80		
Cleaning/replacing UV low-pressure lamps, sunbed base	82		
Cleaning/replacing UV low-pressure lamps, side section	84		
Cleaning/replacing UV low-pressure lamps, canopy	86		
Cleaning/replacing interior lighting.	88		
Cleaning/replacing UV high-pressure lamps/filter panels, canopy and side section.	91		
PRESTIGE 1100: Cleaning/replacing the UV low-pressure lamps in the facial tanner	96		

Important safety notes and information

Safety notices

Description of warning signs

Danger notices, damage to persons:



DANGER!

Type and source of danger, e.g. "DANGER – High voltage!"

Description of the consequences, e.g. "You can be killed or injured by an electric shock!"

Countermeasures:

- Disconnect device from power supply before opening.
- Do not reach into the inside with the device switched on.

Warning notices, damage to persons:



WARNING!

Type and source of danger, e.g. "Warning – hot surface!"

Description of the consequences, e.g. "You can burn your hand (skin, face)!"

Countermeasures:

- Do not touch hot parts and nearby surfaces.
- Wait until hot parts and surfaces have cooled down.

Caution notices, damage to property:



Caution!

The word "Caution" with this label points out that danger for devices, materials and the environment can be expected here.

Important information:



Note:

This symbol does not identify safety notices, but states information for a better understanding of the processes.

Please read and observe ...

Intended use

The tanning device is intended exclusively for cosmetic tanning of the human skin.

- The device is meant for commercial use only, not for home use.
- This device is used for tanning one adult person at a time.
- The user must wear suitable eye protection that blocks UV radiation during tanning.

Any other use shall be considered improper. The manufacturer cannot be held liable for damage or injuries resulting from this. The operator bears the sole risk for this.

The proper use also includes compliance with the manufacturer's instructions, operating and maintenance conditions. This device may only be operated, maintained and repaired by persons familiar with these tasks and who have been informed of the dangers involved.

Obligations of the salon operator

- As the operator you are responsible for informing users on possible risks during tanning.
- All danger and safety labels attached to the device must be observed! Do not remove them!
- No safety equipment (e.g. panel switch) may be removed or deactivated which can impair the safe operation of the device!
- The device may only be operated in a serviceable condition!
- The operator is bound to ensure that the equipment is handled correctly.

Please read and observe ...

Instructions pertaining to a risk of fire, electric shock, or injury



DANGER!

DANGER – High voltage!

You can be killed or injured by an electric shock!

Assembly and electrical connection must comply with national and local regulations.

- The device may only be assembled, installed, upgraded or repaired by specially trained and instructed personnel.



WARNING!

WARNING – ultraviolet radiation!

Unprotected tanning may result in eye injury and eye diseases.

The unprotected eye can become inflamed on the surface, and in certain cases the retina can be damaged by excessive radiation. Cataracts can form after frequently repeated exposure to radiation.

- **Inform users to use the included protective goggles that block UV** (Order No. 84592-..).



WARNING!

WARNING – ultraviolet radiation! Follow instructions!

Failure to use protective eyewear may result in severe burns or other eye injury. If discomfort develops, discontinue use and consult a physician.

- A person who does not tan in the sun most likely will not tan from the use of this device. Persons with very sensitive skins (skin type I) must not use the unit, as with this skin type tanning is impossible without damaging the skin (e.g. sunburn).
- Individuals with acute sunburn, individuals who have had or have skin cancer, or individuals who are at increased risk of skin cancer, must not use the system.
- Seek medical advice if unexpected effects, such as itching, occur within 48 hours of the first session.
- The sunbed must never be used if a filter panel is missing or damaged, or the timer is defective!
- UV light from the sun or UV systems can cause injuries to the skin or eyes. This biological effect is dependent on the sensitivity of the individual's skin and on the type and amount of UV light.
- As with natural sunlight, overexposure can cause eye and skin injury, sunburn, and allergic reactions.

Please read and observe ...



WARNING!

- Repeated exposure may cause premature aging of the skin and skin cancer.
- Medications or cosmetics applied to the skin, may increase sensitivity to ultraviolet light.
- A person having a history of skin problems should consult a physician before use.



WARNING!

WARNING – ultraviolet radiation!

Danger of long-term consequences.

- Overexposure should be avoided.
- The elderly should not use this equipment.
- Nursing infants and small children through age 7 years may not use this device.
- The following applies to minors under the age of 18 years: Only use tanning devices in agreement with a parent or guardian, or after consulting a physician.
- While there is no immediate clinical evidence related to UVA exposure and its effects upon expectant mothers, it is strongly advised that expectant mothers be discouraged from using the tanning unit.



WARNING!

WARNING – risk of infection!

Infections can be transferred through skin contact.

All items/equipment components, with which the user can come into contact during tanning, must be disinfected after every tanning session:

- Protective goggles
- Headrest
- Sunbed acrylic
- Handles and control panel

Please read and observe ...



Note:

Occasionally, persons using the tanning device will experience a slight reddening of the skin – usually in small patches – after the second or third session. This redness is often accompanied by an itching sensation. This may be nothing more than a heat “rash” caused by heat from the lamps within the device. It is generally very limited and caused by constant contact of the skin with the acrylic surface. It should go away within approximately 24 hours and should not reappear. This rashing can be lessened or prevented by applying moisturizing lotion to the affected area after the tanning session is completed.

- Follow instructions.
- The time between the first two tanning sessions must be at least 24 hours.
- Increasing tanning also requires an extension of the exposure time (= radiation time) or after a certain degree of tanning has been achieved, a further intensification is not possible. However, the radiation time may not be extended as desired within the scope of the permissible radiation doses! Therefore, only a certain degree of final tanning dependent on the skin type can be achieved without endangering your health.
- Inform users about proper tanning.

Instructions pertaining to a risk of damage to the machine











CAUTION – danger of overheating!









Danger of overheating by obstruction of the air routing.

- Do not change, obstruct or block the air inflow and outflow area to the device or make any unauthorized changes to the device. The manufacturer shall bear no liability for damage or injuries resulting from such actions.
- Before putting a tanning device into operation, the transport pallet must be removed from under the device. Danger of overheating by obstruction of the air routing.









Please read and observe ...

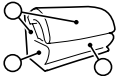









Meaning of symbols

General symbols	
	Contact Customer Service
	Ergoline key
	Do not touch, hot surface!
	Suction cup
	Low-pressure lamp(s)
	UV low-pressure lamp(s)
	Starter for low-pressure lamp(s)
	UV high-pressure lamp(s)

	Filter panels
	Cleaning and disinfectant agents
	Part/item number (for orders)
Operation	
	Display of tanning time
	Display of run-on time (fan run-on)
	Fault display (example)
	Display of Music Channel 1 (Channel 1) Factory setting: 1 channel Customer service can set up to 7 channels
	Display when adjusting volume

Please read and observe ...

	Description
	Accent lights
	Body cooling by AQUA SOLAR WITH SKIN+ ADDITIVE
	Aroma "Relax", "Cabin"
	Press button
	Press button for 2 seconds
	Duration: 3 minutes
	Speaker
	Headphone connection

	MP3 player connection
	see separate manual
Technical Data	
Maintenance	
	Caution, safety switch!
	Unscrew/release screw
	
	Tighten/lock screw
	
	Cleaning
	Replacing

Please read and observe ...



Clean or replace depending on soiling



Draining



Visual inspection



Temptronic



Filter/filter mat



Filter and filter mats must not be damp.



Chipcard of lamp set



Continuation of work steps on next page



End of work step



Presettings

Please read and observe ...

Guidelines

This device was built conforming to UL STD 482, and is certified to CAN/CSA STD C22.2 2 No. 224.

Export

We would like to point out that these devices are exclusively intended for use in the USA and Canada and may not be exported to other countries and operated there! The manufacturer assumes no liability whatsoever in the event of non-compliance! We explicitly emphasize that high liability risks may occur for the exporter and/or the operator in the event of non-compliance.

Accessories

Some accessory parts are taken into account in the maintenance schedule beginning on Page 66, however this does not automatically mean that your device is provided with this equipment.

An overview of the possible accessories is provided in the sales documentation and the planning manual. See page 25 for a selection of these.

Product information

Acrylic glass panels

The acrylic glass panels for the tanning devices are produced from acrylic plastic developed especially for this application. The acrylics used are characterized by a particularly high UV permeability and resistance, as well as an easy-care, hygienic surface that is gentle to the skin.

The acrylic glass panels are formed to their shapes for the specific devices in a technically complex production process. Despite state-of-the-art production know-how, the presence of minor spots, air bubbles or streaks in the acrylic panels is unavoidable. In addition, microfine hairline cracks can occur on the acrylic surface during operation.

These occurrences are material-dependent and are unavoidable in processing, however have no significant effect on the use or value and can therefore not be recognized as defects.



CAUTION!

Cosmetics or sun screen products must be removed prior to using the sunbed as they can cause damage (e.g. fine cracks on the surface) when used continuously.

Please read and observe ...

MP3 music (optional) - Advice for the studio owner

If an MP3 player is used privately during tanning, then this does **not** constitute a public performance in the sense of copyright law, so that no reporting or fee obligation to the corresponding copyright owning company in respect of copyright exists on the part of the studio operator.

The same regulations apply to the public use of MP3 music files as to all other music sources. As a studio operator/studio owner, you may only play original Audio-CDs, MCs, audio-DVDs etc., on your premises and/ or play music via the "MP3-music modules" which are provided in the professional sunbeds in the Ergoline range, if you have acquired the necessary stage rights¹⁾.

Copy-protected audio CDs, MCs, audio DVDs etc., as well as the tracks included on these media, are not allowed to be converted to MP3 format and / or stored on hard discs, audio CDs, MCs, audio DVDs etc. when software and / or computer programs are used for this purpose which cancel or avoid the copy-protection included on the storage media.

At the request of the external staff or any other controlling body of the responsible company, you must always be in a position to prove that you have purchased the performance rights by showing the relevant authorisation.

As long you follow the advice given above and have gained of the necessary rights, you may convert your original audio CDs, MCs, audio DVDs etc. to the MP3 format required for the player. However, you may

only create one copy (either a duplicate or a conversion to MP3 format) for each audio CD, MC, audio DVD etc. for which you have obtained the legal rights. The original sound storage medium must be stored and is not allowed to be used at the same time.

1) from the company responsible for granting commercial performance rights in your country (in Germany: GEMA/GVL)

Please read and observe ...

Environmental protection information

Environmental Declaration – The JK Corporate Group

The JK corporate group is subject to the strict regulations of EC Directive 761/2001 and the ISO 14001 standard, and undergoes regular internal and external environment audits performed by trained auditors.

Environmental regulations – disposal of lamps

UV-low pressure lamps and UV high-pressure lamps contain fluorescent materials and other waste containing mercury.

According to the national waste disposal laws and in accordance with the municipal waste regulations, proof must be provided of the proper disposal of UV lamps.

Your local environmental agency will be happy to assist you with the disposal of UV lamps.

Packaging

All packaging consists of 100 % recyclable materials.

Disposal of recyclable materials

The device has been produced of recyclable materials. When being permanently removed from operation, the device must be disposed of properly. Sun Ergoline will provide you with information on the content or potential hazards of the materials used.

Maintenance and care



Extreme danger! High voltage!

During maintenance work there is a risk of touching live parts and receiving a fatal electric shock.

- Disconnect device from power supply before opening – also see Page 65.
- Do not reach behind covers and do not open the device with the device switched on.
- Refit any safety devices (e.g. switches) after the work has been completed.

Maintenance and care play a major role in deciding whether the device meets the requirements placed on it in a satisfactory manner. The compliance with the specified maintenance intervals and the careful conducting of the maintenance and care work are therefore absolutely necessary – see Page 66.

The current operating hours of the parts requiring maintenance can be displayed in the Presetting mode.



CAUTION!

Only use **genuine** spare parts of the same type!

The use of other parts may limit or void your manufacturer's warranty!

Any liability is excluded in case of damage or injury proven to be the result of the use of non-genuine spare parts.

Please read and observe ...

Cleaning

Acrylic glass surfaces



CAUTION!

Do not rub with a dry cloth – danger of scratching!

For fast, hygienic proper cleaning of acrylic glass surfaces, use a specially developed fast disinfectant cleaner.

Other cleaning agents, especially concentrated disinfectants or solvents (e. g. Lysoform, ethyl alcohol or other liquids containing alcohol) must never be used for cleaning.

Failure to observe this voids all warranty claims.

Plastic surfaces

For cleaning the other plastic surfaces, it is best to use warm water and a leather cloth. Never use aggressive cleaning agents containing alcohol or essential oils. These may lead, in the long run, to damage not covered by the warranty.

During cleaning, a slight discoloration of the leather cloth by the rubber seals must be expected for production-related reasons.



Note:

Prevent damage to plastic surfaces. Remove rings, watches, bracelets etc. before the start of cleaning work.

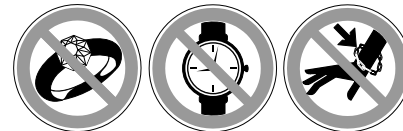

02756 / 0

Please read and observe ...

Use the sunbed – but use it properly!

A few things need to be noted to get maximum enjoyment from a sunbed. Here are the answers to some frequently asked questions.

Make-up on the sunbed?

Please remove make-up or don't use make-up while tanning. Clean skin absorbs UV light better.

A wide variety of ingredients are found in cosmetics. Again, whether these are emulsifiers, greases, or so-called scents – in conjunction with UV radiation, these can cause allergic reactions of the skin.

Accordingly, a must before using a sunbed is: Remove all make-up. This is essential. Make-up clogs the pores in the face. The UV light from a sunbed re-opens these clogged pores so that not only does the light penetrate the skin, but also the allergenic components of the make-up.

A further negative consequence of make-up is that the appearance of the skin deteriorates irreversibly over a period of time. However good a decent make-up might be – in conjunction with UV light, it causes more harm than good. Therefore: Remove all make-up before a session on your sunbed – it will be much better applied afterwards.

Showering after leaving the sunbed?

The browning is in the skin, not on the surface. Therefore you cannot wash it off. Treat your skin to a moisturizing cream after showering.

Are medications and the sunbed compatible?

It is known that some medications increase the skin's sensitivity to UV light. This probability is particularly high with antibiotics, sulphonamides, psychiatric drugs, tranquillizers, anti-diabetes treatments and diuretics. Sun creams which contain psorale or kumarin also increase skin sensitivity. If you are in any doubt, first ask your doctor – then you can enjoy the sun at no risk.

Contact lenses on the sunbed?

The answer is: Yes! Like any other sunbed user, contact lens wearers should also wear special protective goggles which protect the eyes against UV radiation. To guarantee better protection, wearers of spectacles and contact lenses can ask their optician for exchange contact lenses with UV protection. The UV-A and UV-B filters built into exchange contact lenses will protect the cornea and the internal parts of the eye against almost 100% of the energy in UV radiation.

This will benefit sunbed users not only in the open air, but on the sunbed itself. For more information, ask your optician or optometrist.

Operation

Mandatory reading

Always read and follow all instructions for proper usage prior to allow anybody using a tanning device. The operating instructions included with this device must always be followed to prevent possible injuries or to reduce them to a minimum.

Inform users

- to use provided UV-blocking protective eyewear whenever the equipment is energized.
- to follow the exposure schedule in accordance with their skin type. Failure to do so may result in overexposure.

A tanning system is not a toy. You cannot vary the strength of the lamps in your unit.

Should you have any questions regarding the proper use of your tanning system, contact Global Service USA at:

☎ (800) 445-0624

7:00 a.m. to 7:00 p.m. (CT)



Warning – ultraviolet radiation!

Danger of skin injuries and skin diseases!

- The sunbed must never be used when a filter panel is missing or damaged, or the timer is defective!

WARNING!



Note:

When describing the operation, the tanning device is often shown with the canopy open. During tanning the canopy must always be closed.

Proper operation is not possible with the canopy open.



Operation

Device description

1. Facial cooling: air nozzles
2. Facial tanner (UV high-pressure lamps)
3. Shoulder tanner with sound system
4. Headphone jack and MP3 connection
5. Infrared interface
6. Acrylic glass panel, sunbed base
7. Intermediate panel
8. UV low-pressure lamps: sunbed base
9. Body cooling: air nozzles at feet end
10. UV low-pressure lamps: side section
11. UV low-pressure lamps: canopy
12. AQUA MIST AROMA System nozzles
13. Body cooling: air nozzles
14. Operating handle
15. Display unit
16. Accent lights: interior
17. Central exhaust air connection (optional)
18. Accent lights: canopy
19. Illuminated text
20. Accent lights: front panel
21. Enclosed tanning tunnel
(Series for PRESTIGE 1100)

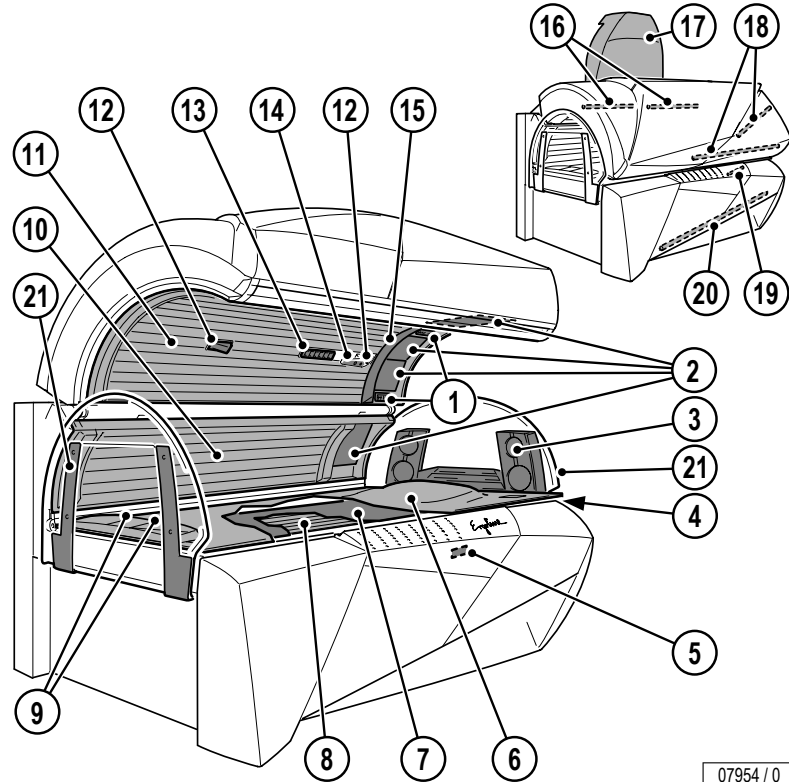

07954 / 0

Accessories

- 3. Shoulder tanner with sound system
- 17. Central exhaust air connection
- 21. Enclosed tanning tunnel

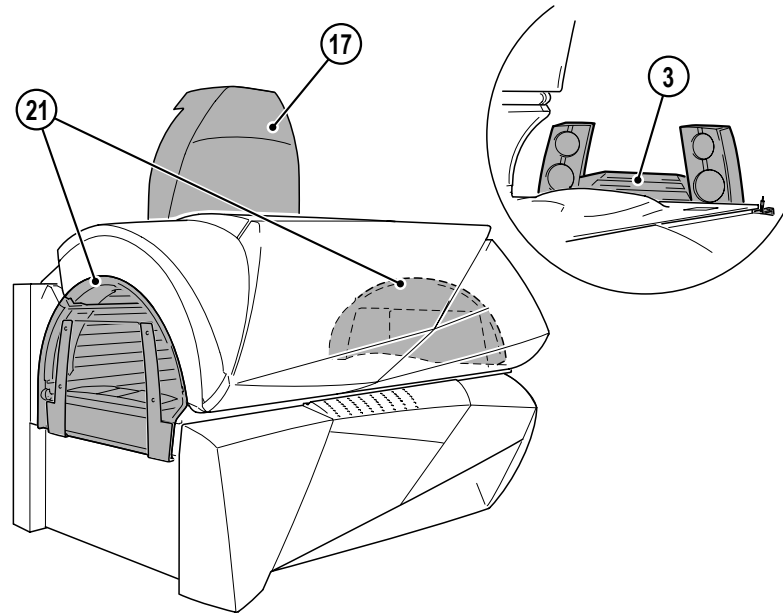

16021 / 0



Operation

Operation at a glance

Operation

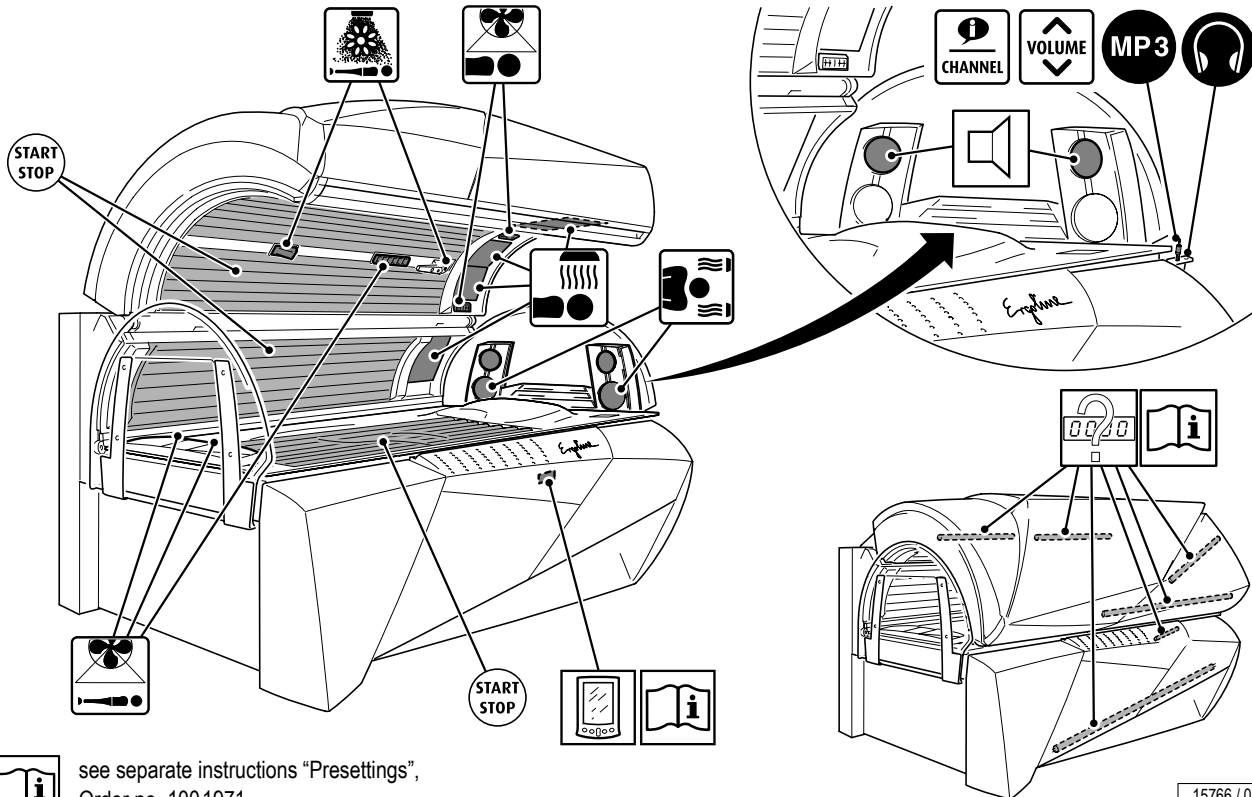

see separate instructions "Presettings",
Order no. 1001971

15766 / 0

Operation buttons and display unit

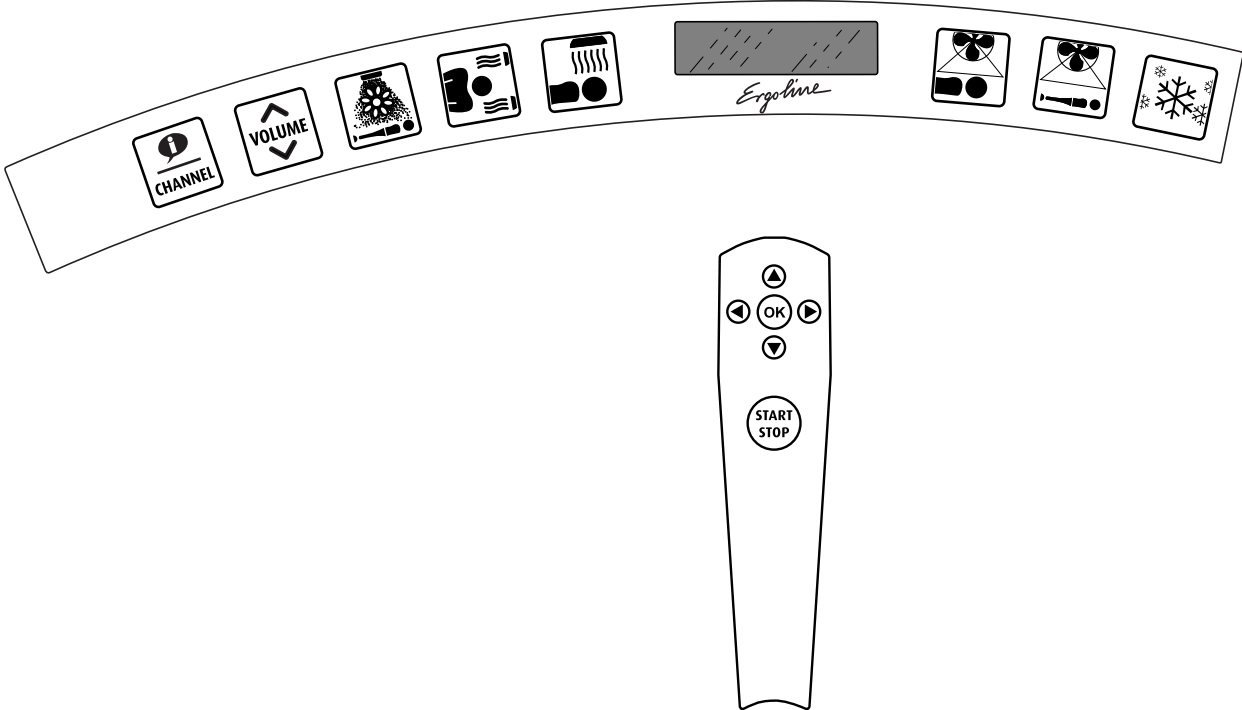

07700 / 0

Operation / Navigation

The sunbed is operated with the buttons on the operating handle in the canopy.



Switch tanning on and off, pause.



Confirm function.

Whether this button is available depends on the function selected and is shown in the display.



Select device function
(go to pictogram)



Select sub-function (if available)

Change setting (progress bar display)

Change music track or studio channel (in default mode)



Whether this button is available depends on the function selected and is shown in the display.

All pictograms on the display unit are illuminated in default mode after starting up the sunbed.

After selecting a function, the corresponding pictogram flashes and the setting or selection options for the chosen function are shown in the display. (See "Operating structure" Page 29.)



Note:

If a button is not pressed within 8 seconds, the settings return to default mode.

Operating structure

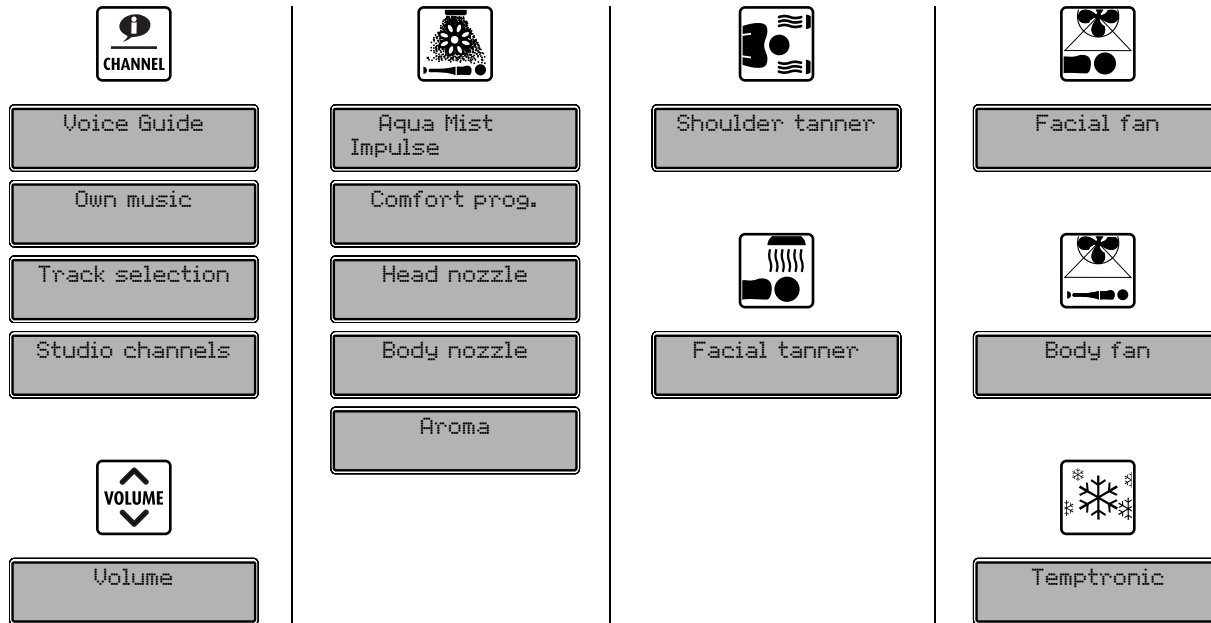

Start of tanning

The device is started automatically with an internal or external timer.



Note:

Timer instructions: see separate manual¹⁾.

Preparation time

Before the UV lamps turn on, you have a few minutes to prepare yourself. During the preparation time you can switch on the UV lamps at any time by pressing the START/STOP button.

- Remove your clothes and all jewelry.
- Remove make-up and other cosmetics.
- Remove glasses. Contact lenses can be worn under the protective goggles.
- Put on the protective goggles.
- Lie down on the bed surface.
- Close the canopy.
- Press the START/STOP button.

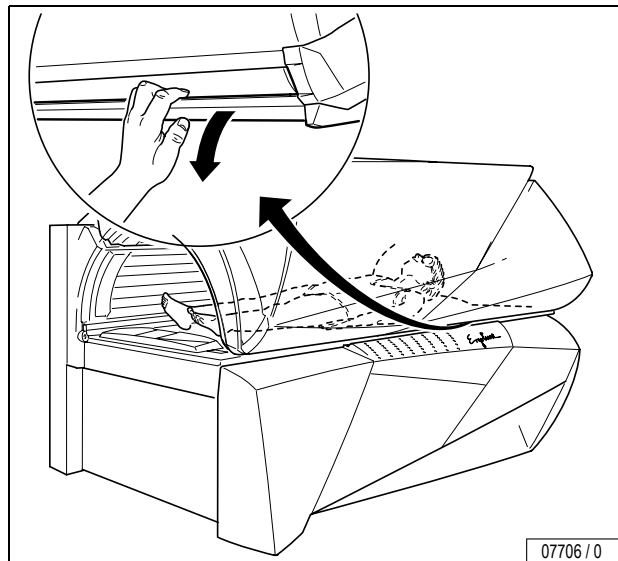

1) Order no 801129-..

Interrupt or end tanning session

The tanning session ends automatically after the preset time has run down. The internal fan continues to run for approx. three (3) minutes to sufficiently cool the device.

- To interrupt a tanning session, press button START/STOP anytime during a session.
- Press START/STOP again to restart the lamps.

Settings on start-up

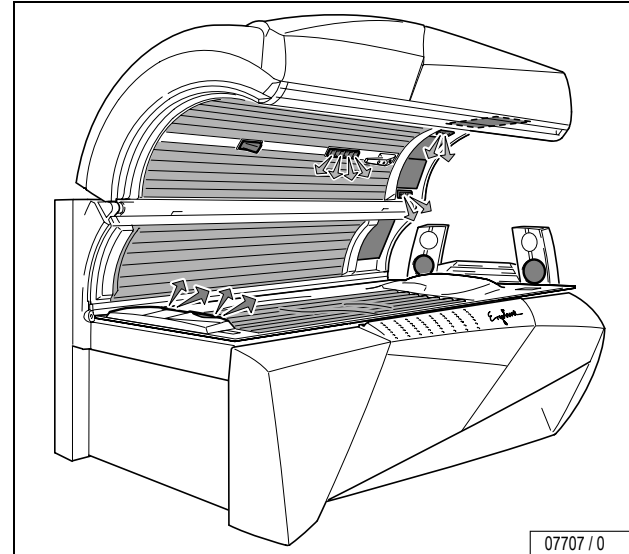

Operation



Running time of accent lights

The accent lights are automatically switched on at the end of the tanning session after the set operating time and are switched off again at the beginning of the next tanning session.

The running time of the accent lights in the Standby mode can be changed with the presettings.

Operation

Stand-by

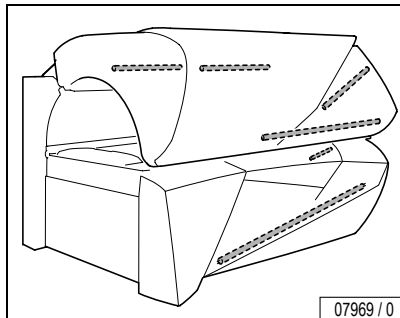
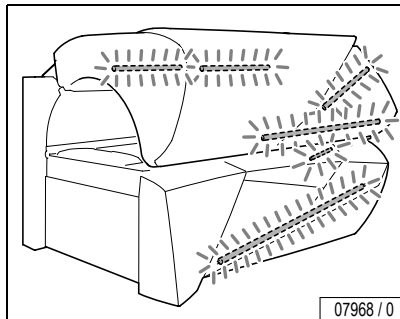

IR Function

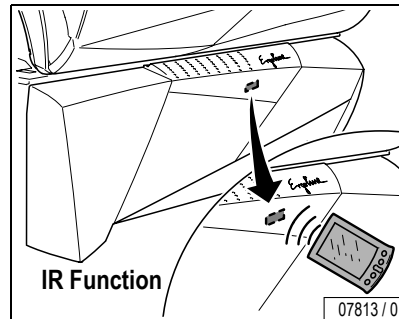

see separate instructions
"Presettings", Order no. 1001971



Regulating facial tanners



- Press the **up** or **down** button to adjust the intensity of the facial tanners.
- Press the **down** and **OK** button to switch the facial tanners off.
- Press the **up** button to switch the facial tanners on again.
It takes approx. one (1) minute until the facial tanners reach their full output.

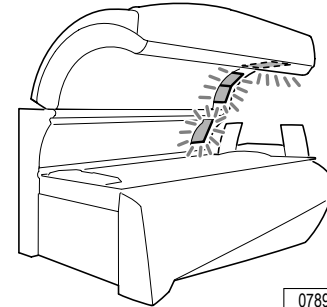

Operation

07896 / 0

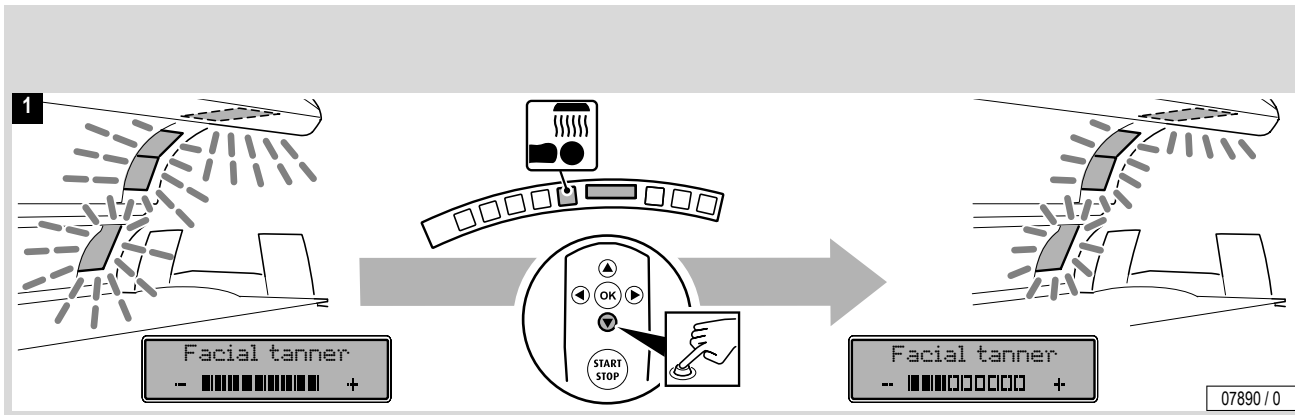

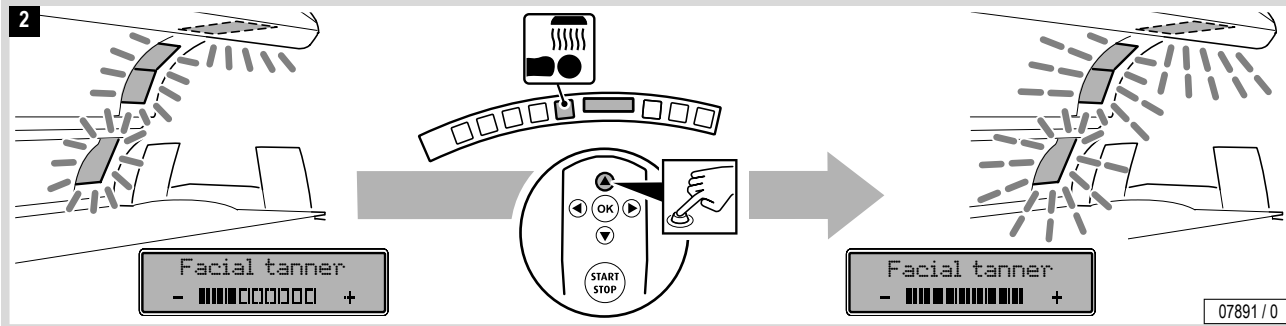

STOP

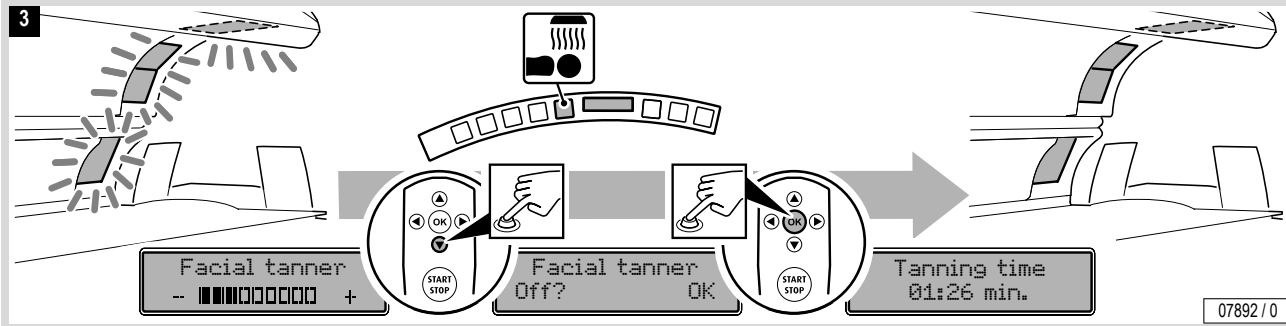

START

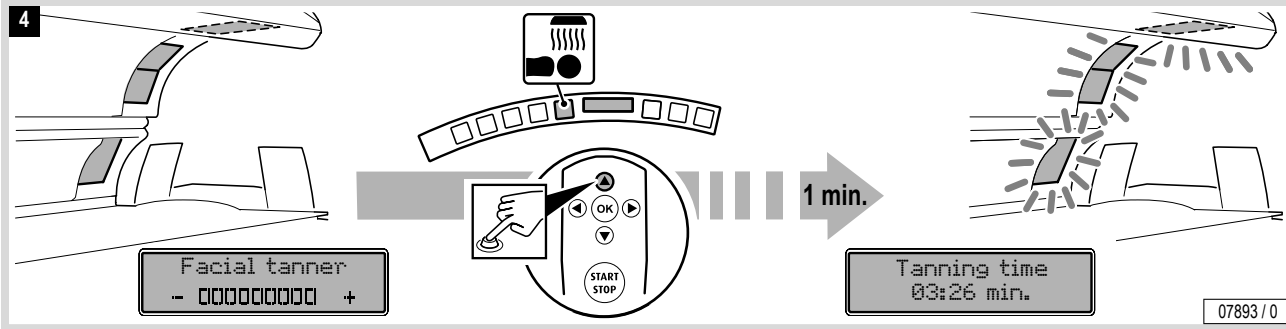

Switching the shoulder tanner off and on



- Press the **OK** button to switch the shoulder tanner off and on. After switching on again, it takes approx. one (1) minute until the shoulder tanner reaches its full output.



Operation

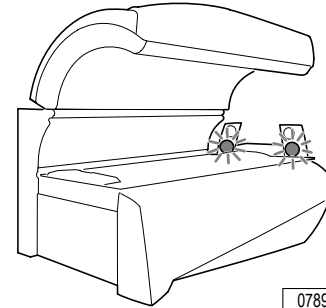

07897 / 0

STOP

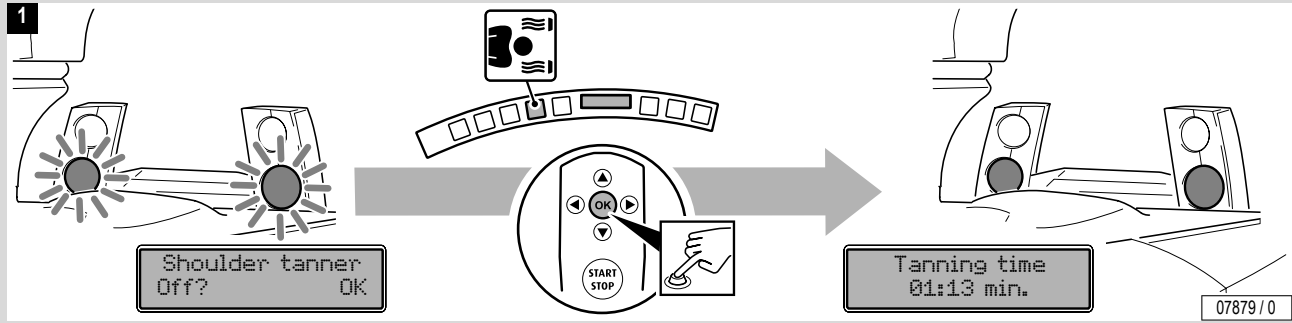

Switching the shoulder tanner off and on

START

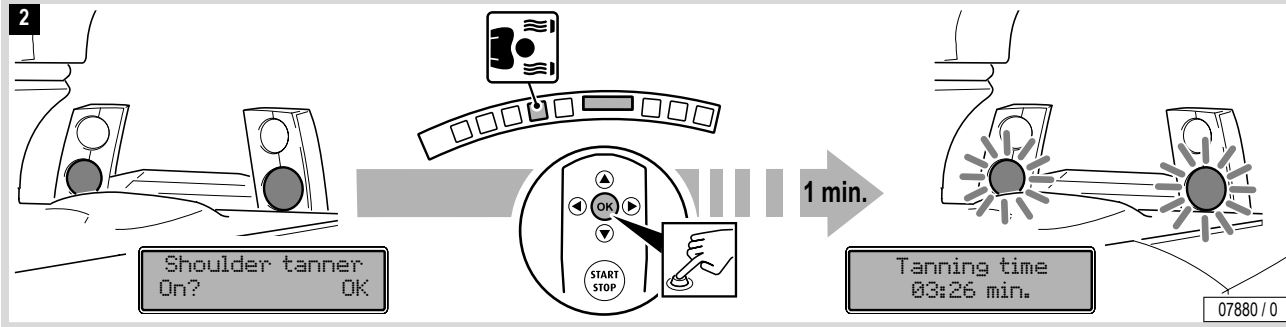

Operation



Temptronic – Adjust coolness



– Press the **up** or **down** button to change the cooling intensity.



Note:

If the automatic air conditioning (Temptronic) fails, the acrylic glass panel is cooled without adjustment control. In this event, the user can only switch the cooling system on or off.

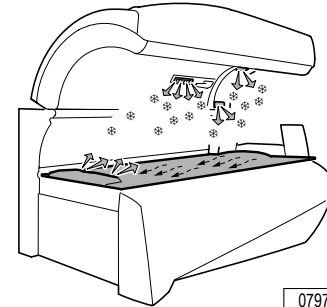

07975 / 0

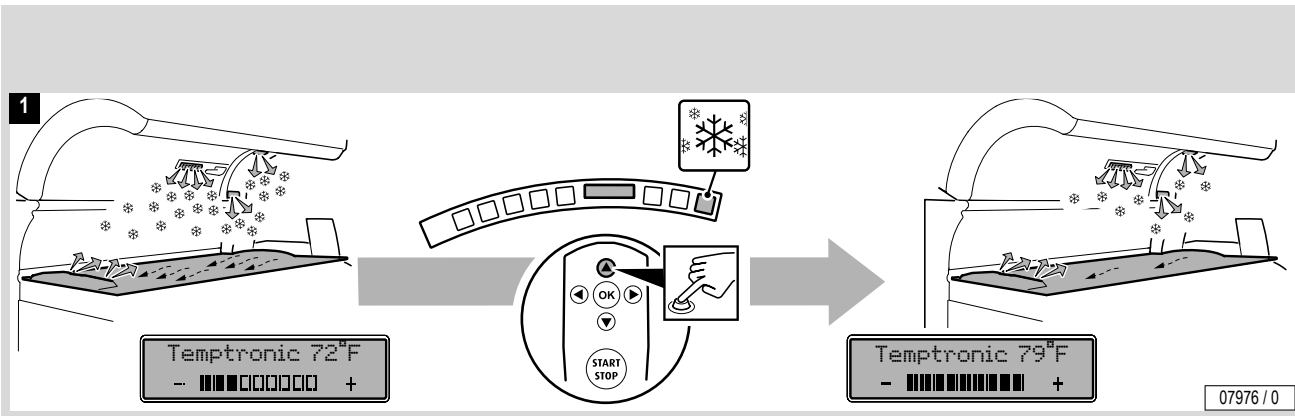

07976 / 0

Temptronic – Adjust coolness

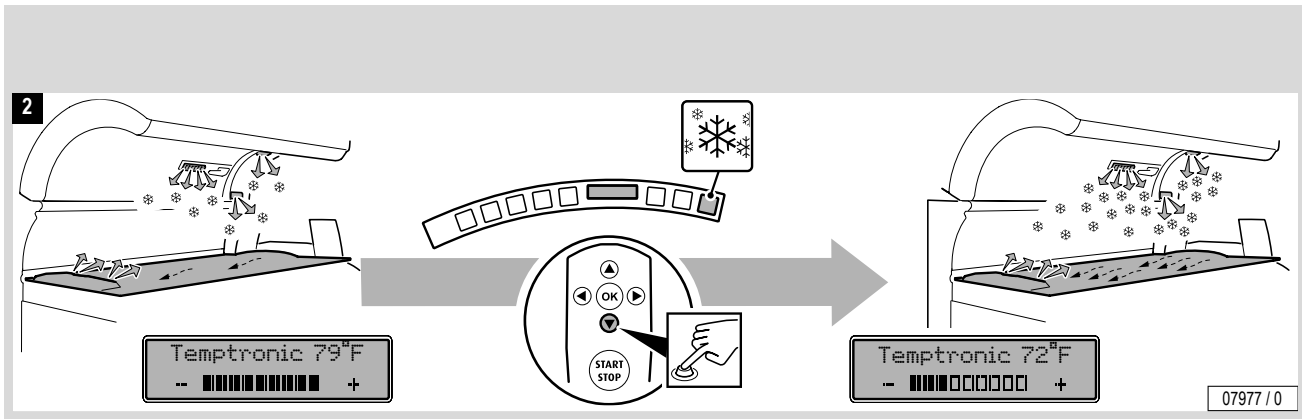

Operation



Regulating body cooling



- Press the **up** or **down** button to change the intensity of the air stream.

Operation

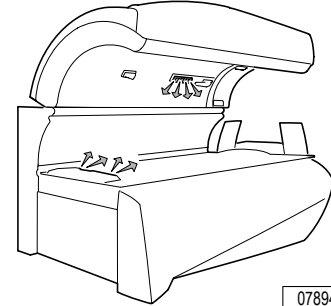

07894 / 0

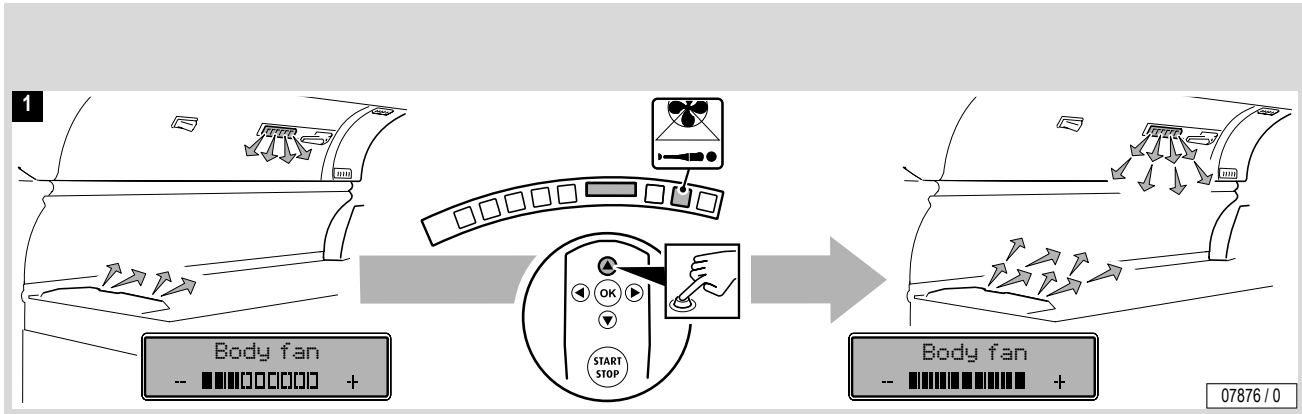

Regulating body cooling

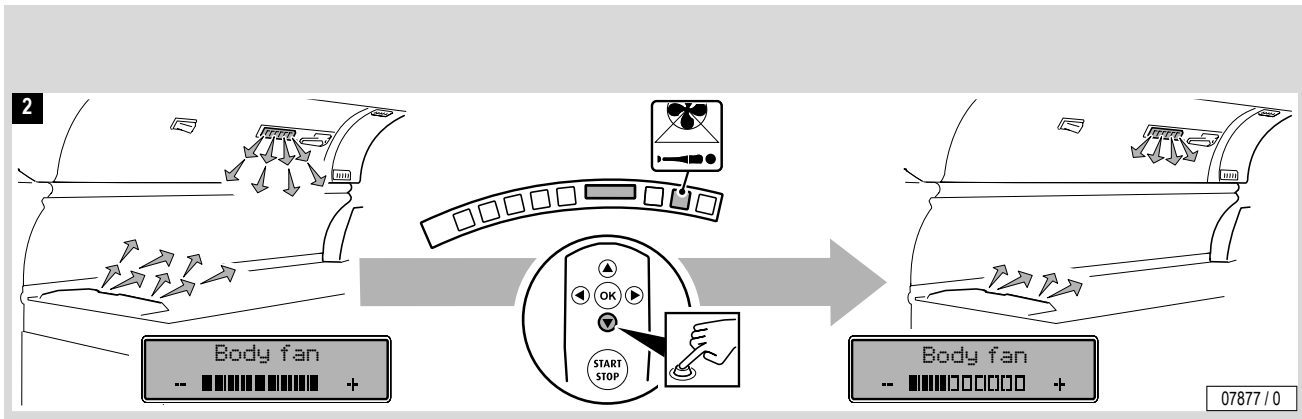

Operation



Regulating facial cooling



- Press the **up** or **down** button to change the intensity of the air stream.

Operation

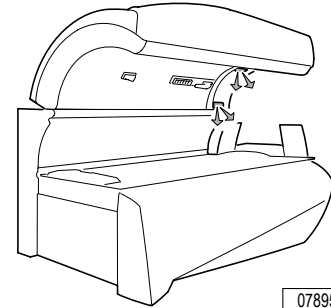

07895 / 0

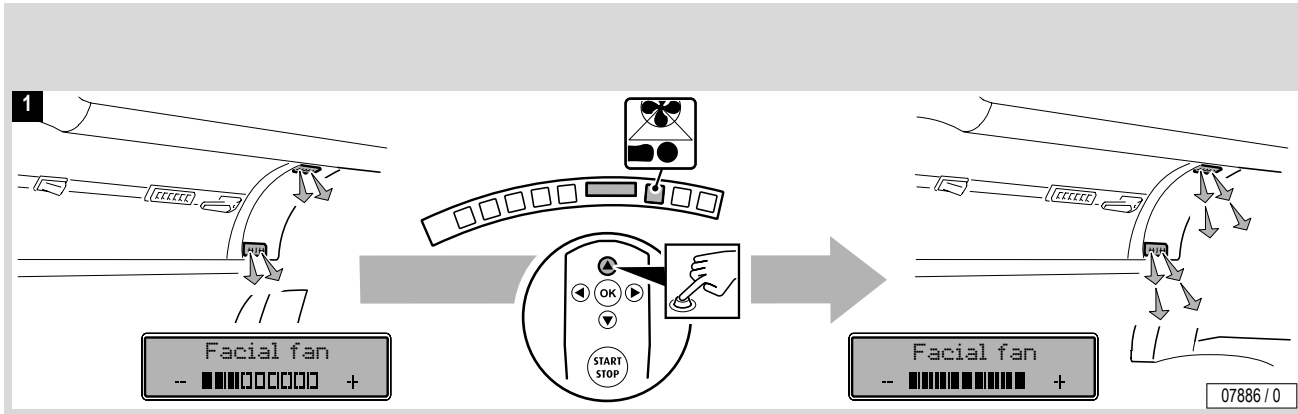

Regulating facial cooling

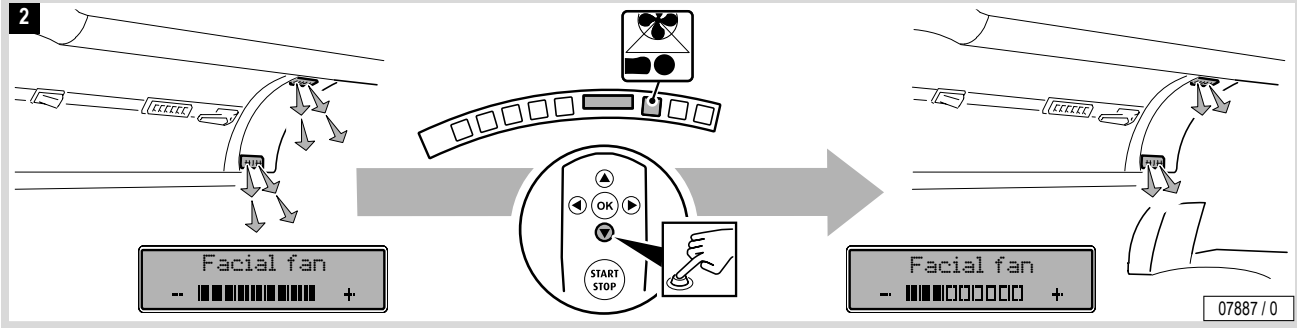

Operation

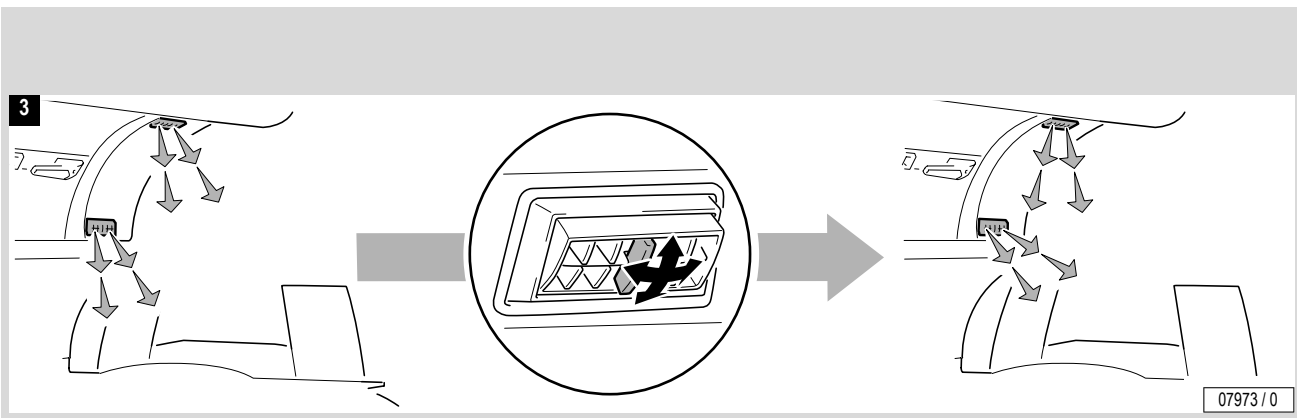

Activating AQUA MIST Impulse



The AQUA MIST function sprays a fine mist of AQUA SOLAR WITH SKIN+ ADDITIVE in the interior of the sunbed for face and body cooling. The AQUA MIST AROMA system includes an aroma with the scent "Relax", which is distributed via the head nozzles.

- Press the **OK** button to activate an AQUA MIST impulse.

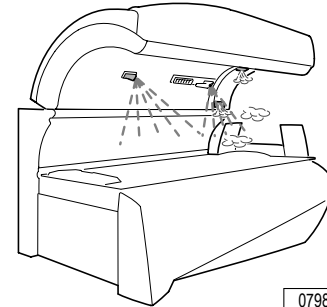

07985 / 0

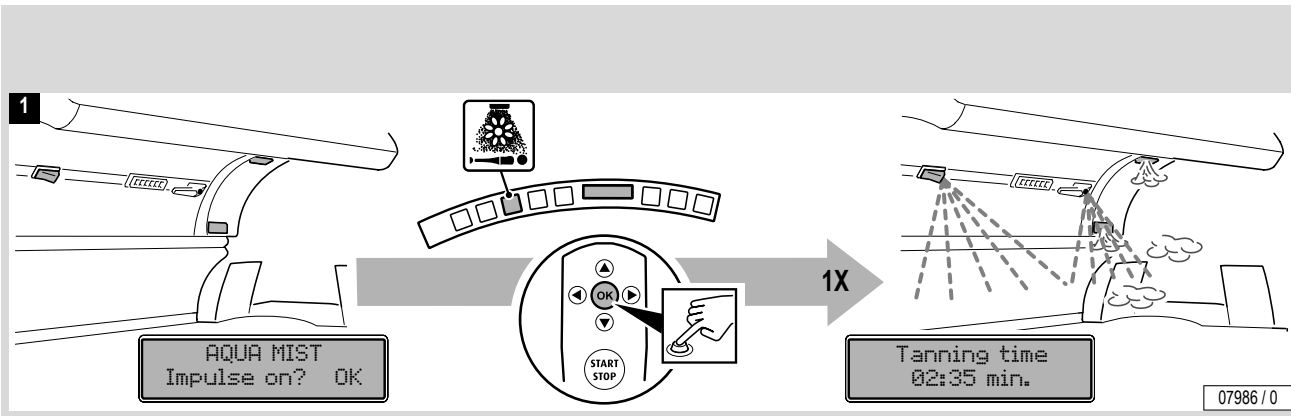

Switching AQUA MIST comfort program on and off



The AQUA MIST function sprays a fine mist of AQUA SOLAR WITH SKIN+ ADDITIVE in the interior of the sunbed for face and body cooling. The AQUA MIST AROMA system includes an aroma with the scent "Relax", which is distributed via the head nozzles.

- Press the **OK** button to switch the AQUA MIST comfort program on and off.

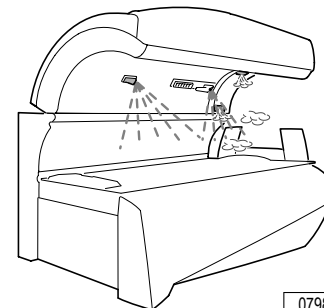

07985 / 0



Operation

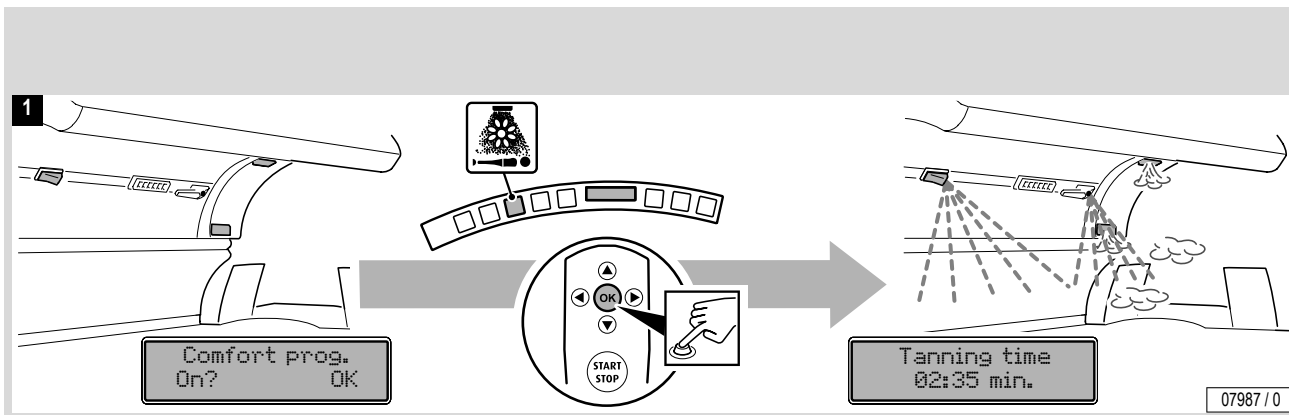

Switching AQUA MIST comfort program on and off

Operation

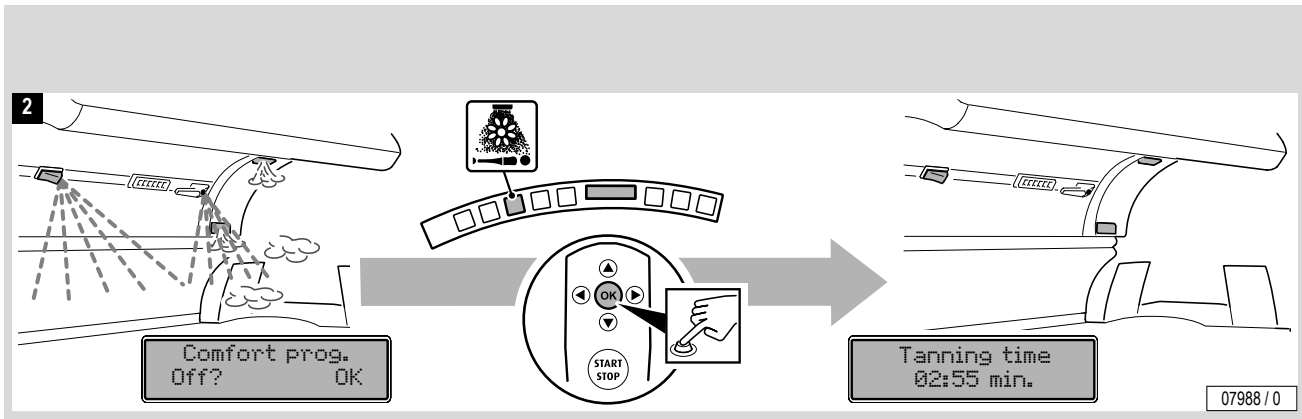

Switching AQUA MIST head nozzle off and on



- Press the **OK** button to switch the AQUA MIST head nozzle off and on.

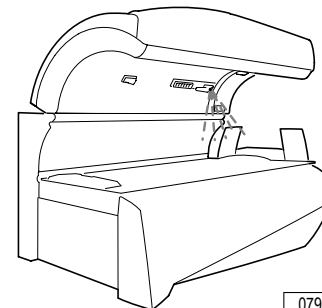

07996 / 0



Operation

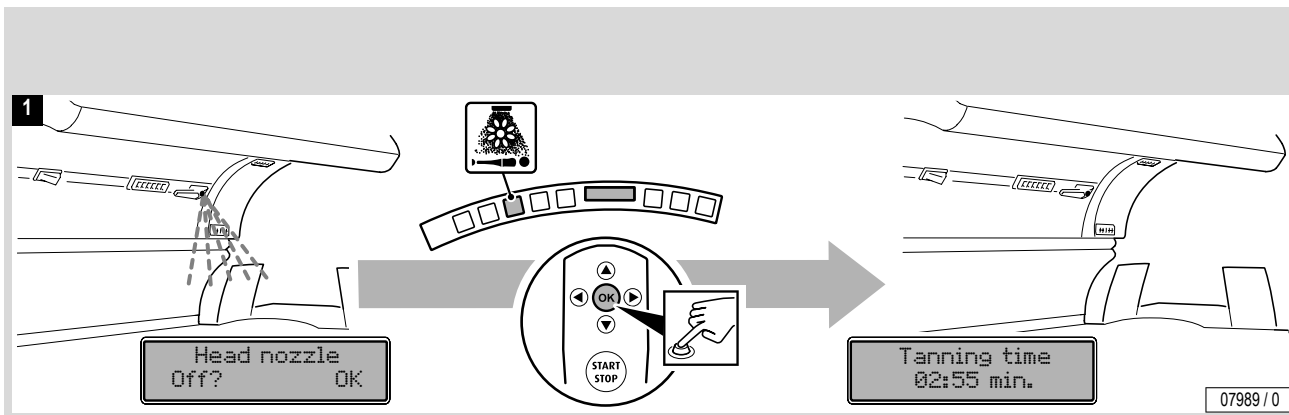

Switching AQUA MIST head nozzle off and on

Operation

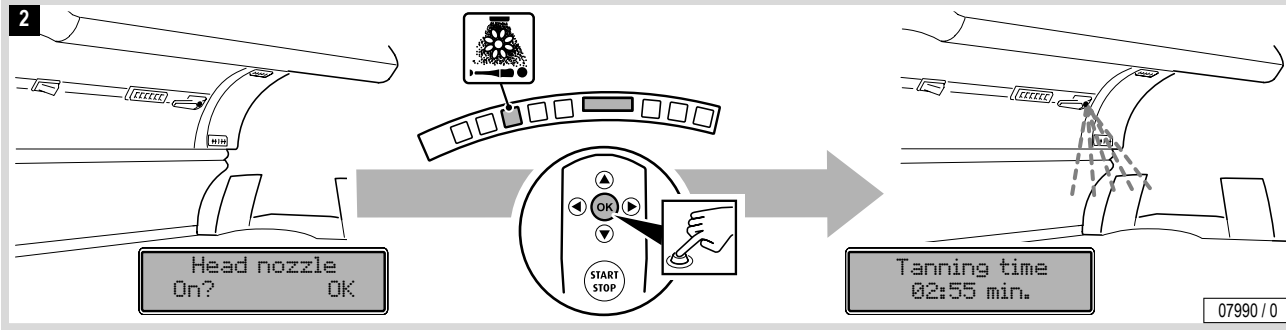

Switching AQUA MIST body nozzle off and on



- Press the **OK** button to switch the AQUA MIST body nozzle off and on.

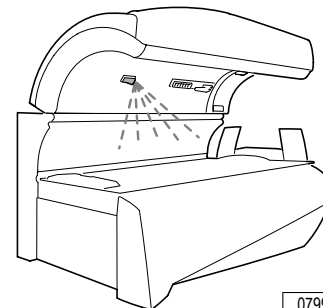

07998 / 0



Operation

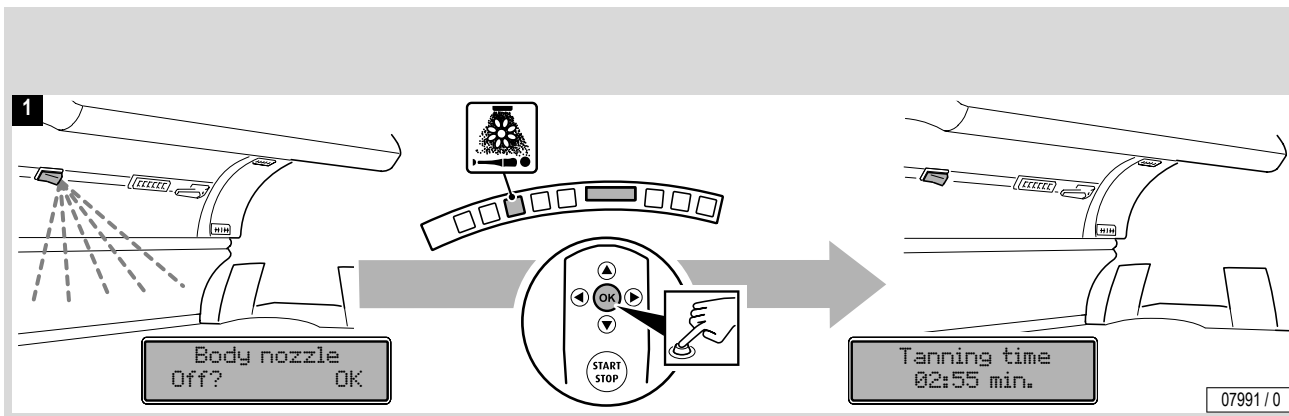

Switching AQUA MIST body nozzle off and on

Operation

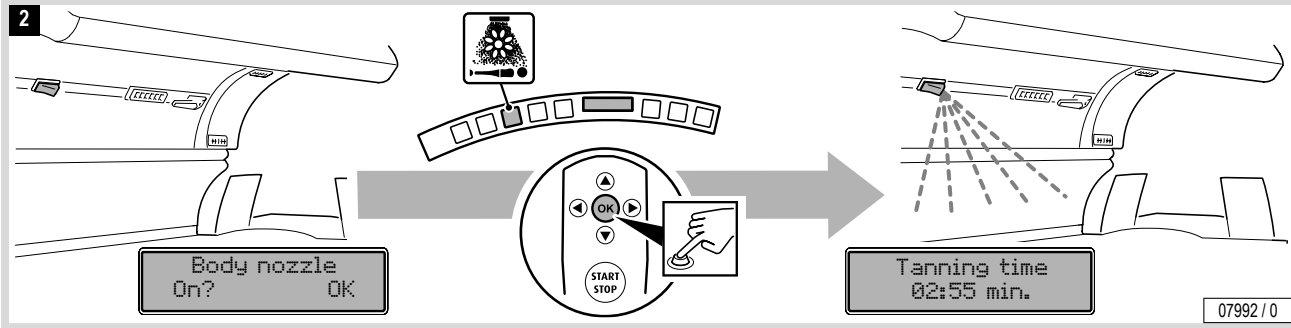

Switching AROMA off and on



- Press the **OK** button to switch AROMA off and on.

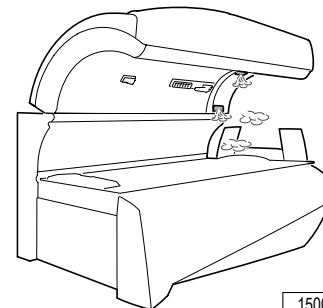

15001 / 0



Operation

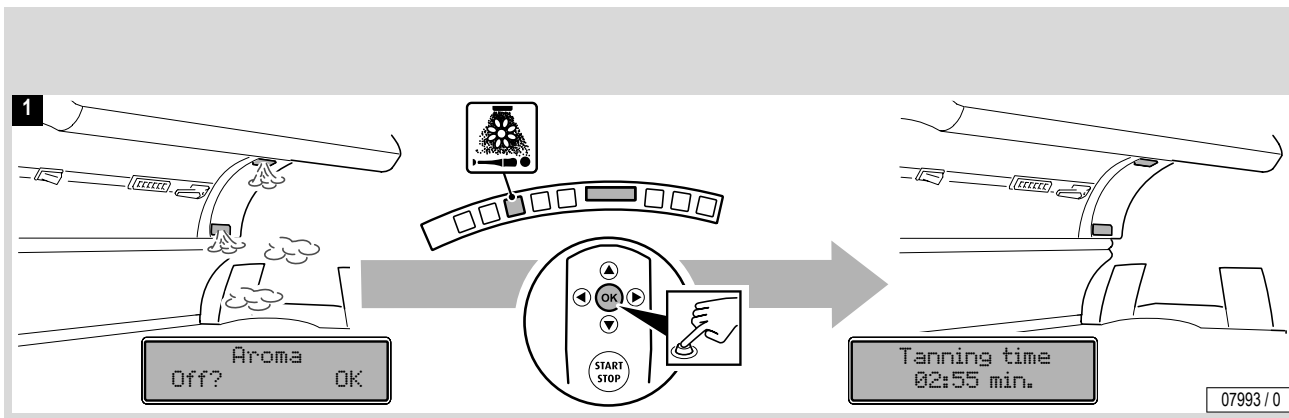

Switching AROMA off and on

Operation

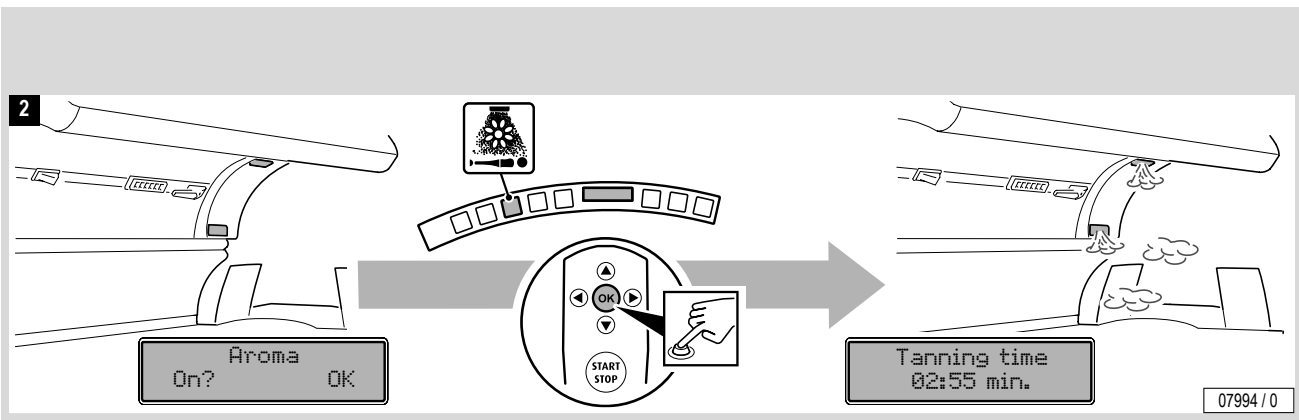

Voice Guide



Voice Guide gives acoustic guidance when operating the device and is only available in conjunction with the audio system.

Voice Guide is activated by default during both stand-by and a tanning session.

- Press the **OK** button to switch Voice Guide off and on.

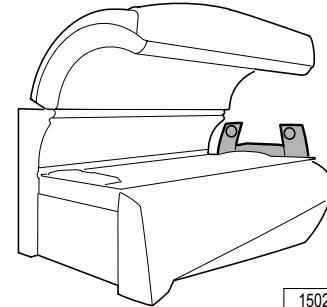

15026 / 0



Operation

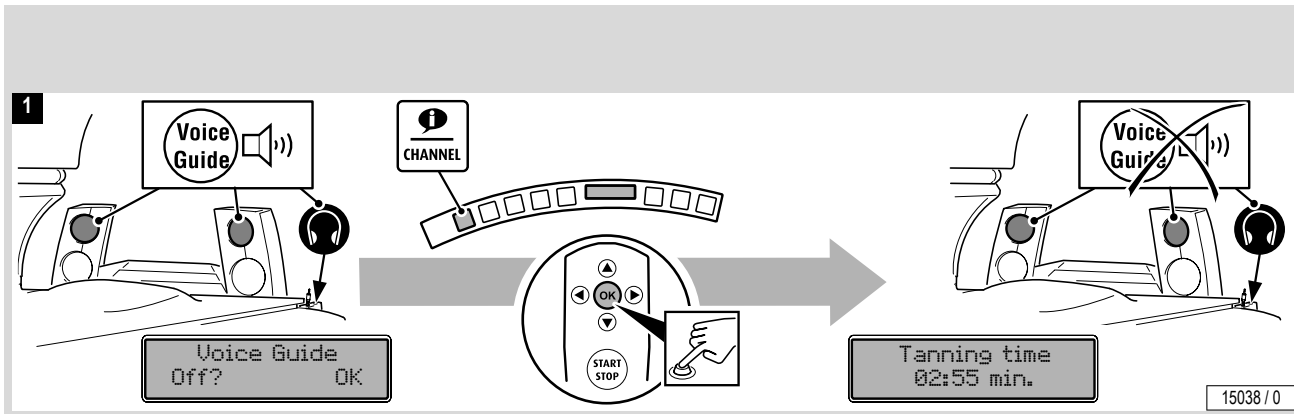

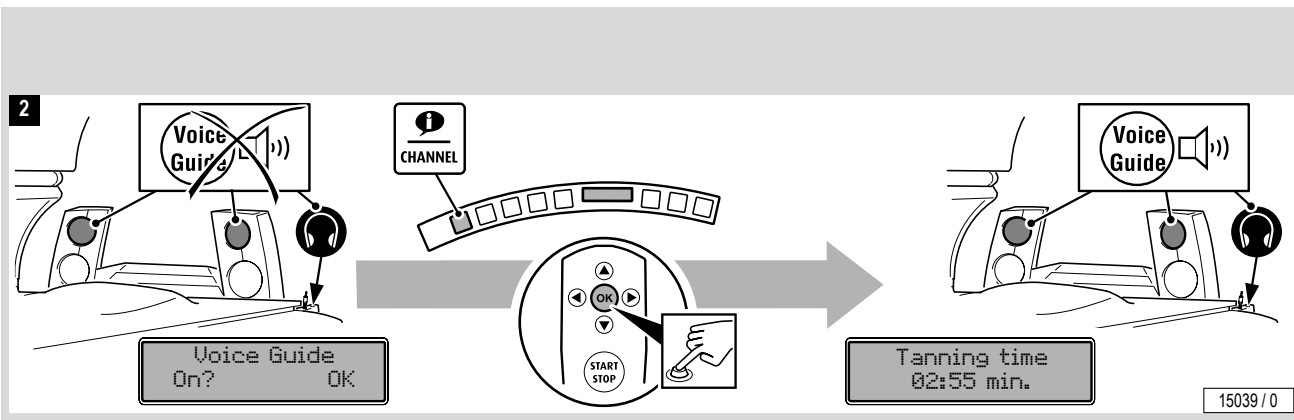

Selecting audio system



A	Own music	MP3 player
B	Track selection	Music SD card
C	Studio channels	Externally connected systems (e.g. CD players)

Example:

Selecting studio channels as audio system



Note:

Selecting an audio system automatically deactivates the others.

- Press the **OK** button to select the audio system.

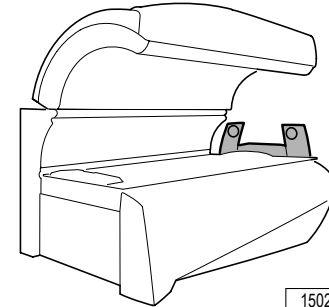

15026 / 0



Operation

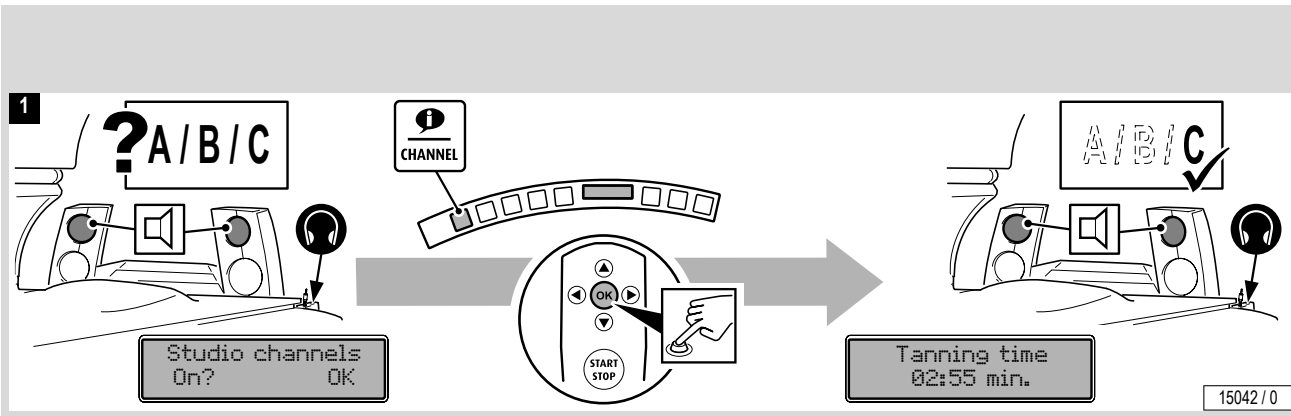

Adjusting volume



WARNING!

Risk of hearing loss!

- With time, the human ear becomes accustomed to high sound levels.
 - The higher you adjust the volume, the quicker the hearing can be damaged.
 - The use of ear pieces and headphones at high volume can lead to permanent hearing loss.
- Press the **up** or **down** button to change the volume.

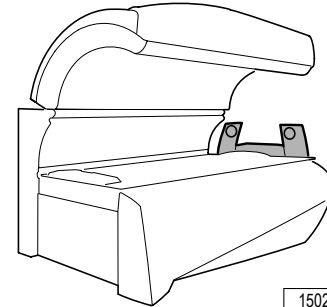

15026 / 0

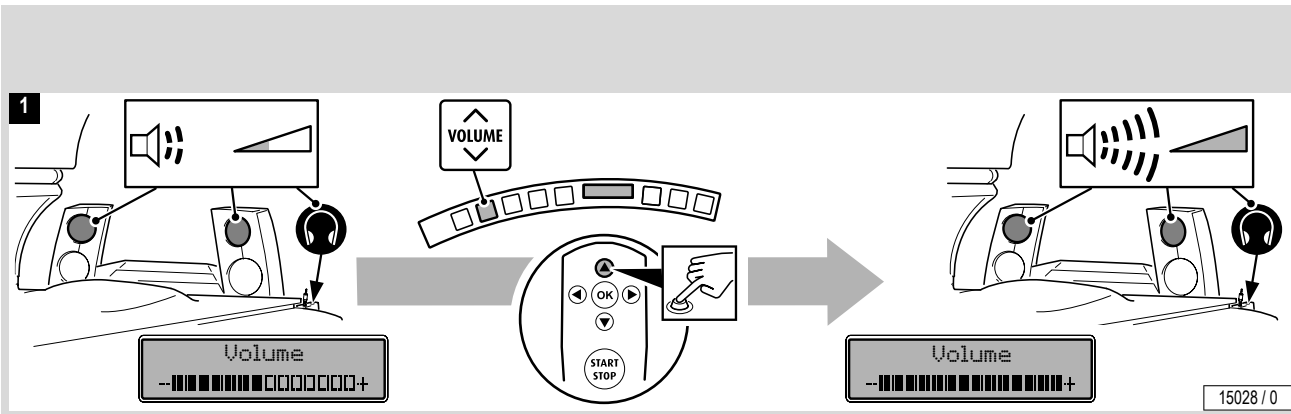

Adjusting volume

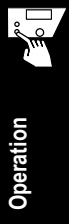
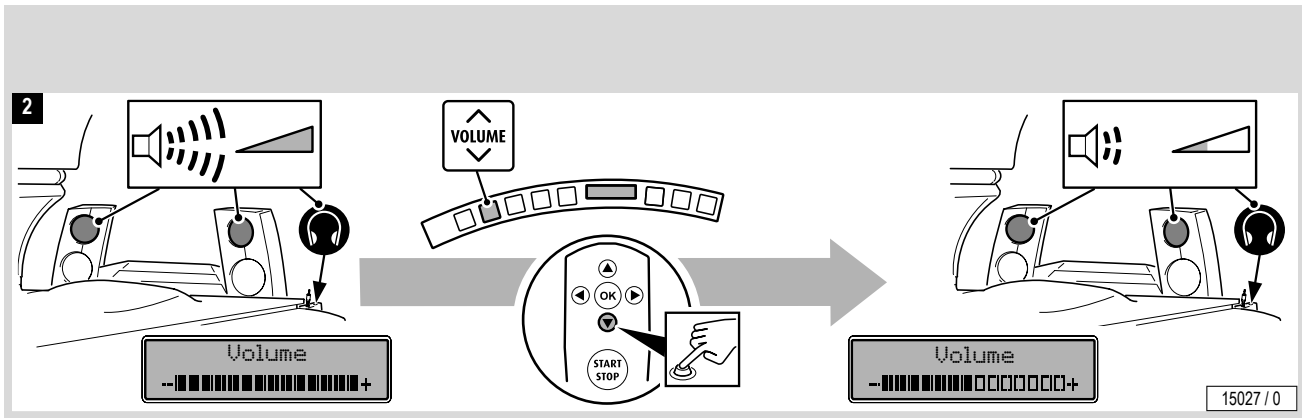

Changing music track or studio music channel

- Press the **up** or **down** button to change the music track or studio music channel.



Operation

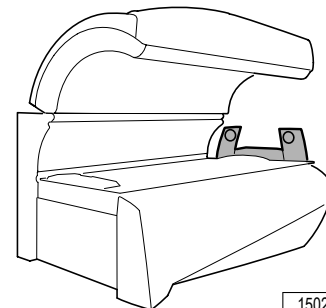

15026 / 0

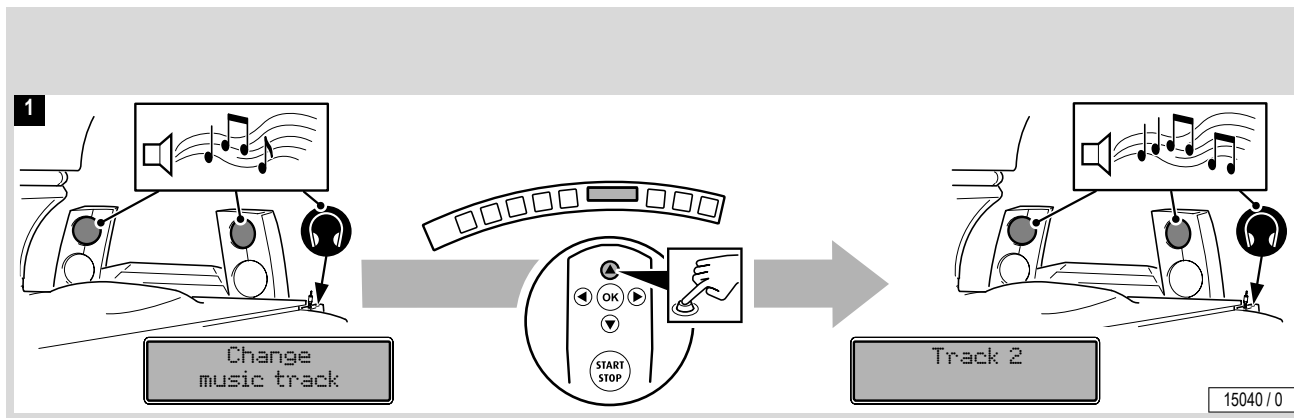

Changing music track or studio music channel

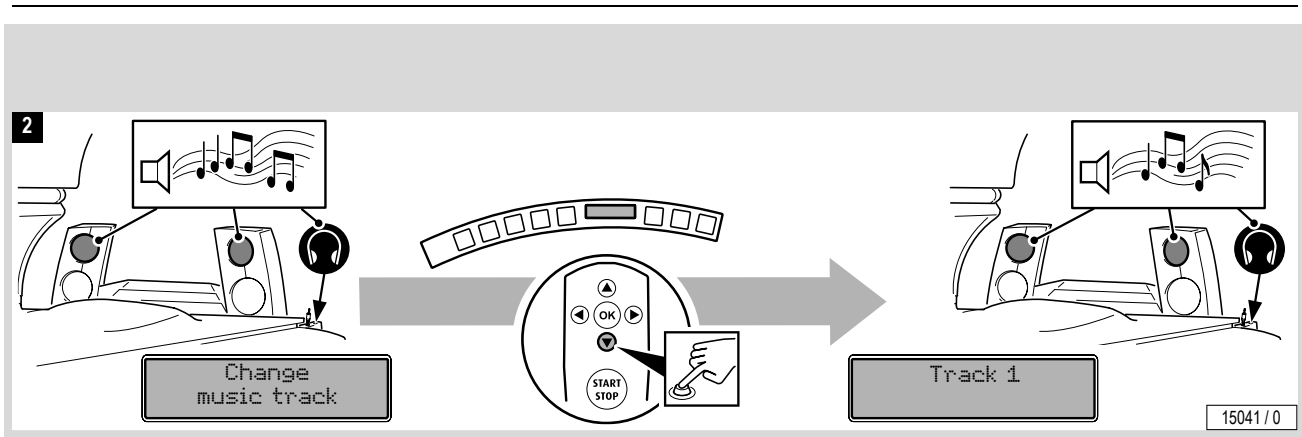

Connecting an MP3 player

Studio customers can connect their own MP3 player to the device when the “Audio System” accessory is available.

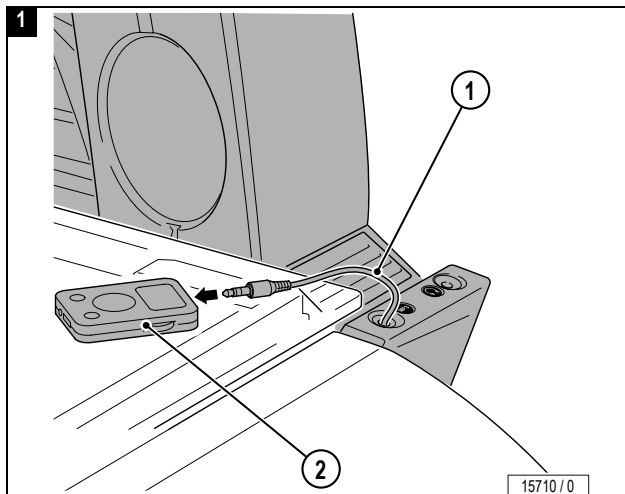

- ① 3.5 mm stereo jack plug.
- ② Connection for an MP3 player: see manufacturer's instructions.

Loud music might disturb other studio users!

- Use headphones whenever necessary.

MP3

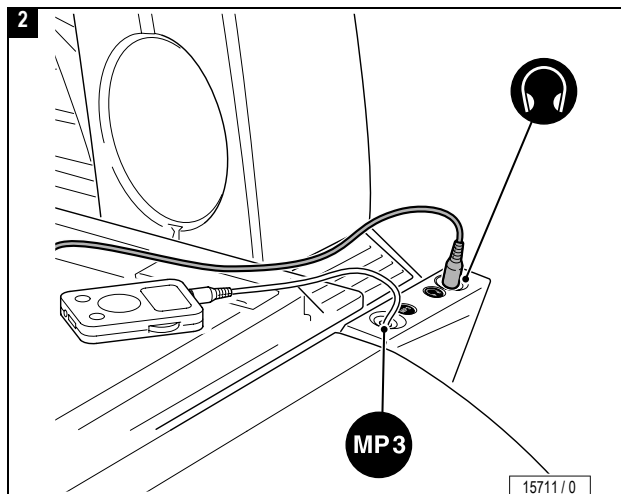



Caution!

Heat can damage your MP3 player

- Do not place the MP3 player on the irradiated area.

Cable may be torn off, connectors may be damaged.

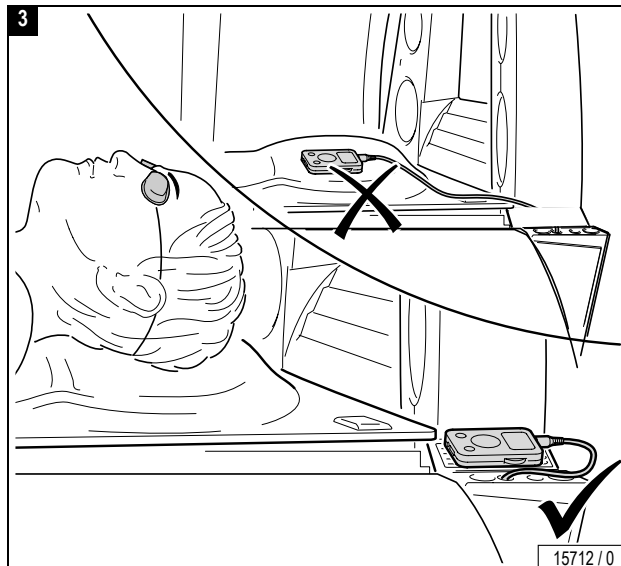

- Do not pull cable when unplugging MP3 player.



Operation



Technical data

Model:	Ergoline Prestige 990 Dynamic Power Temptronic (Plus)	Ergoline Prestige 1100 Extreme Power Temptronic Plus
Rated power consumption:	18500 W	18500 W
Rated voltage:	230V	230V
Rated frequency:	60 Hz	60 Hz
Rated fusing:	80 amp 3-pole	80 amp 3-pole
Conformity mark:		

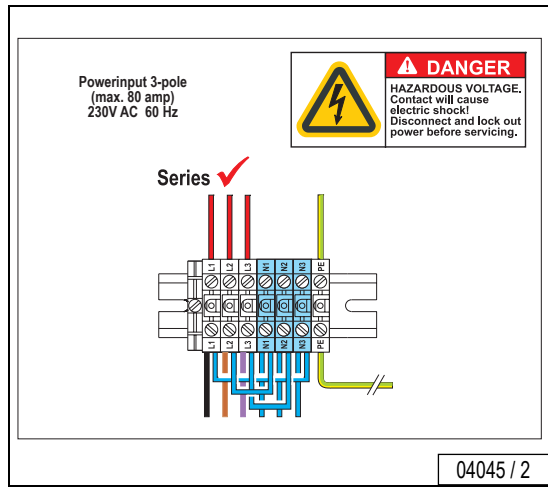



Bed tolerance in room

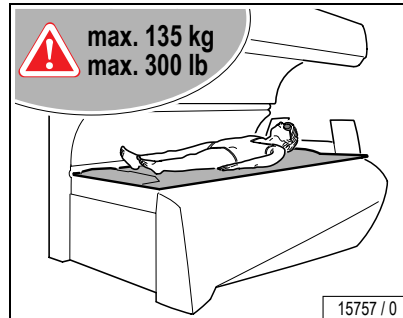
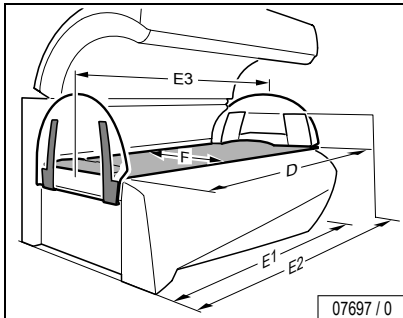
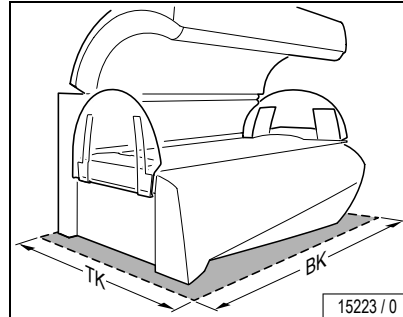
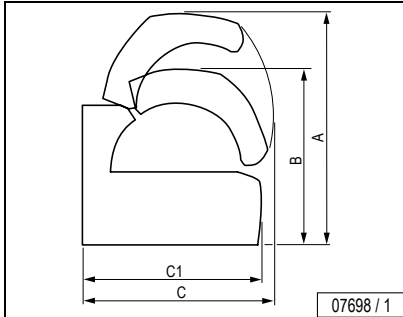

A	=	79 in	2,006 mm
B	=	60 1/4 in	1,531 mm
C	=	62 1/16 in	1,576 mm
C1	=	59 1/16 in	1,500 mm
D	=	86 5/8 in	2,200 mm
E1	=	87 15/16 in	2,234 mm
E2	=	93 11/16 in	2,380 mm
E3	=	94 1/8 in	2,390 mm
F	=	37 1/2 in	953 mm
BK ¹⁾	=	8 ft	2,400 mm
BK ²⁾	=	8 1/4 ft	2,500 mm
TK	=	7 1/2 ft	2,300 mm

- 1) without enclosed tanning tunnel
 2) with enclosed tanning tunnel



Maximum room temperature / Humidity

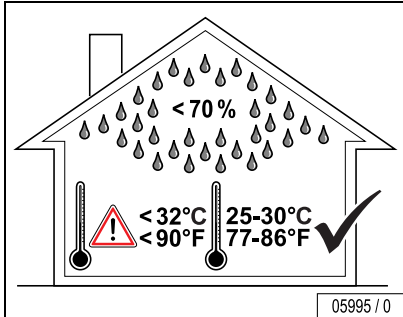

Acoustic level during tanning

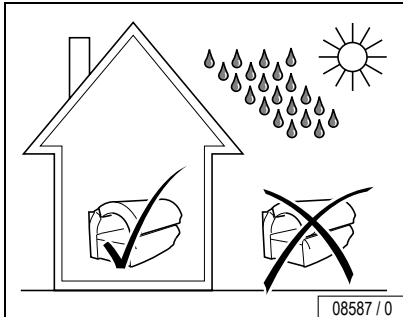
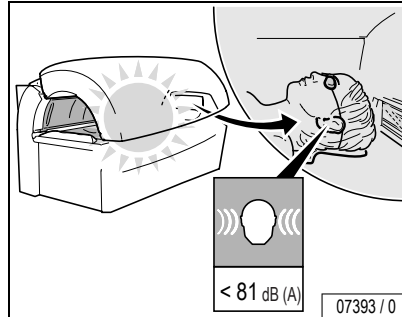

PRESTIGE 990 DYNAMIC POWER

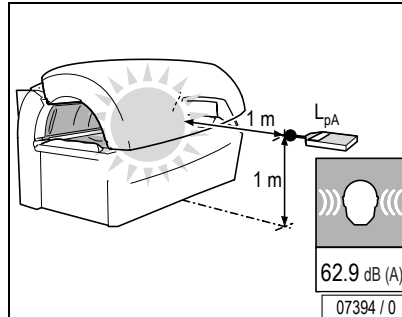

PRESTIGE 1100 EXTREME POWER

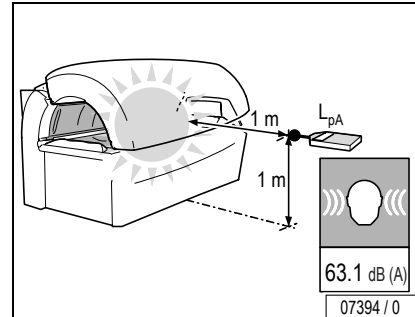

Maintenance instructions

Power Off device and secure against being switched on again



Extreme danger!

If work is to be performed on the devices, they must be powered off. That means that all live lines must be switched off. Switching off the device alone is insufficient, as certain points may remain energized. Therefore, switch off and lockout circuit breakers before performing any work.

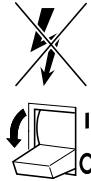

04049 / 0

- A strip of adhesive tape with the wording “DANGER do not switch ON!” may be applied over the actuation levers of circuit breakers which cannot be removed.

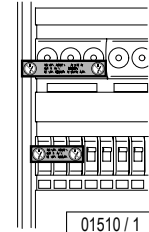

01510 / 1



Extreme danger!

Severe accidents can occur if the device is mistakenly switched on again. Immediately after powering off, secure all switches or fuses used for power against being switched on again.

A prohibition sign with the text:

“Work in progress!”

- “Place:”
 - “Sign may only be removed by:”
- must always be securely mounted immediately.



01511 / 1



DANGER!

Extreme danger!

Prohibition signs must not be hung on or touch live parts.



Maintenance: overview

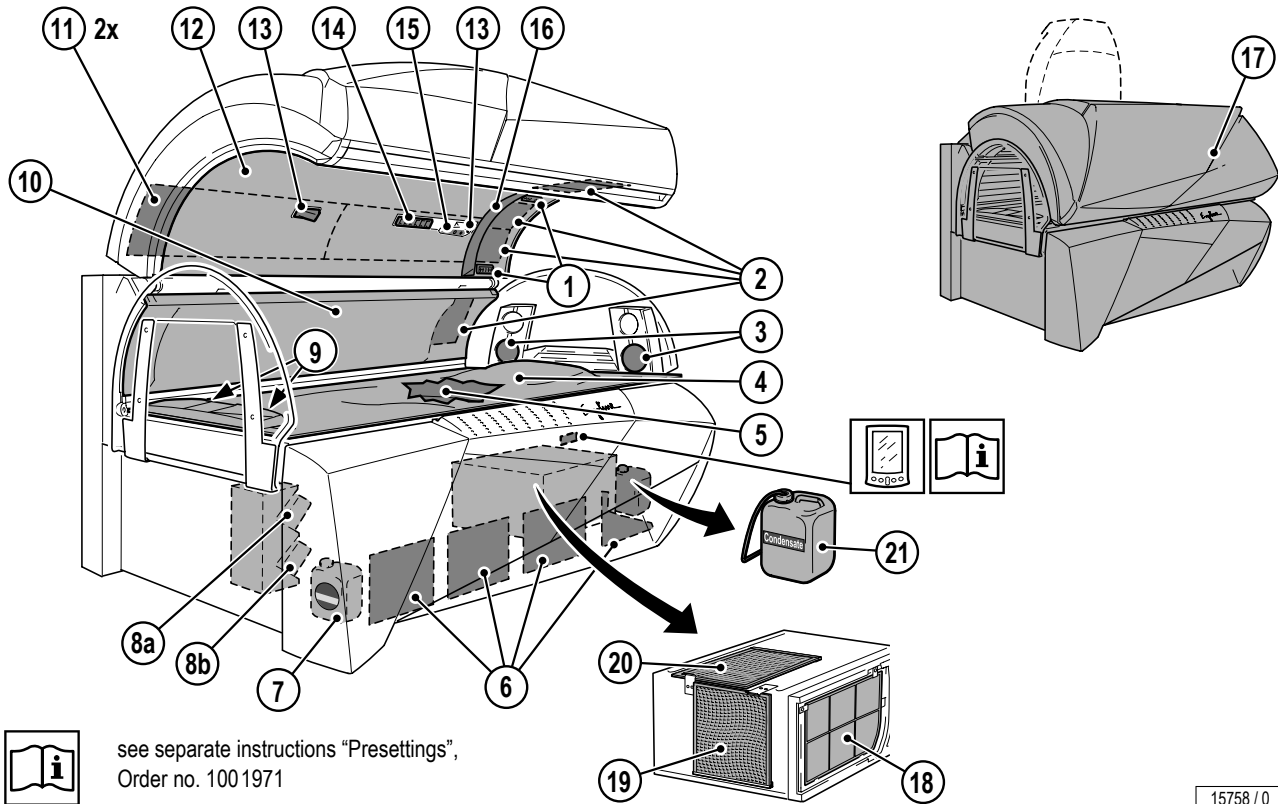

Maintenance 





Scheduled cleaning

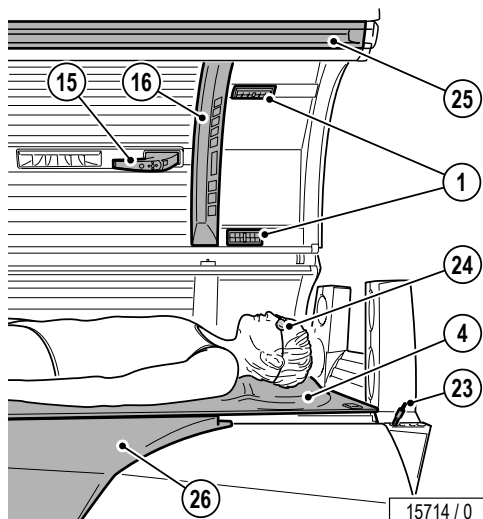

15 - 16



1

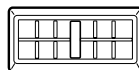

24



4

25 - 26

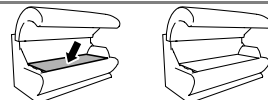

23

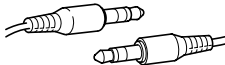

Note:
Clean after every use.



WARNING – risk of eye irritation!
Protective goggles may only be cleaned with an approved disinfectant.



Note:
Confirm cleaning by holding down the START/STOP button (when the follow-up time of the fan in the sunbed has finished).



Scheduled cleaning

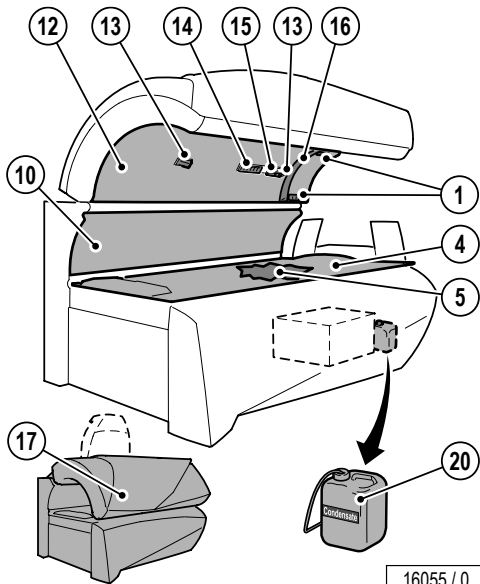

16055 / 0



① - ⑬

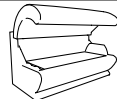

⑬

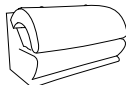

④



⑳



Note:
Clean/drain if necessary!

Maintenance



Scheduled cleaning – filters, filter mats

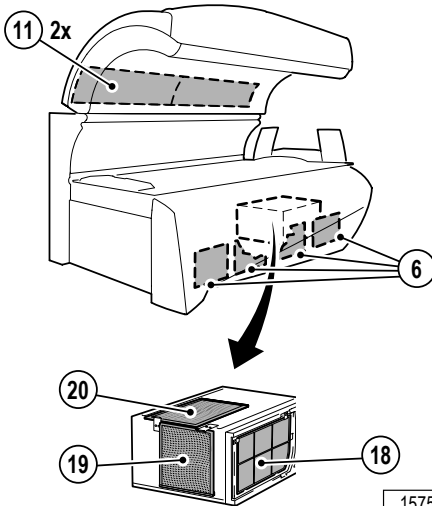

15759 / 0

		/50 h	
⑥	4 x		52104-.. 104
⑪	2 x		843150-.. 106
⑱	1 x		51975-.. 107, 110
⑲	1 x		51937-.. 107, 110
⑳	1 x		51937-.. 110





Scheduled maintenance – AROMA, AQUA MIST

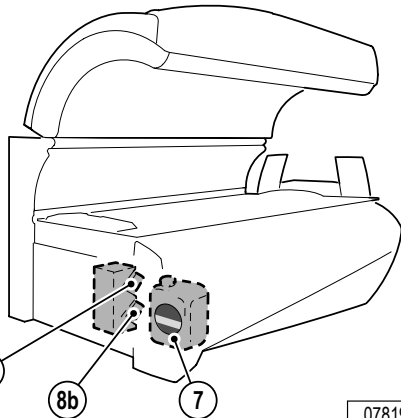

07819 / 0



7



6,000 ml

3652603-..

113

Intervals ¹⁾

7



1)



300 h

8



100 ml

a) Relax: 3652003-..
b) Cabin: 3652203-..

115

a) b)

¹⁾ Intervals, see "AQUA SYSTEM PRODUCT INFORMATION" (Order no. 801610).

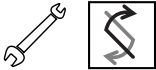

Scheduled replacement – accent lights, starters (Design Silverpearl Blue)

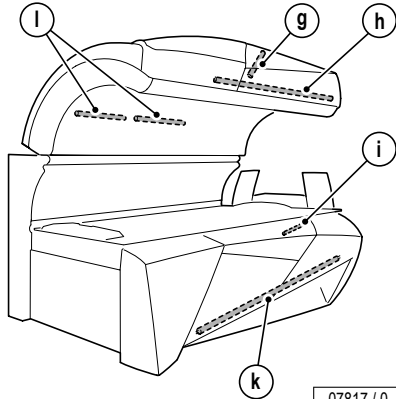

07817 / 0



g)	1 x		blue	36 W	11792-..	99
h)	1 x		blue	58 W	12063-..	99
i)	1 x		white	8 W	11839-..	101
k)	1 x		blue	36 W	11792-..	101
l) with AQUA MIST AROMA SYSTEM						
	2 x		blue	15 W	1002103-..	88
	with 2 x		Makrolon tube blue		1002145-..	88
l) without AQUA MIST AROMA SYSTEM						
	1 x		white	38 W	1002555-..	88
	with 1 x		Makrolon tube blue		1002556-..	88
1000 h						
g) - l)	6 x		S10		10047-..	88, 99, 101



Scheduled replacement – accent lights, starters (Design Shining Blue)

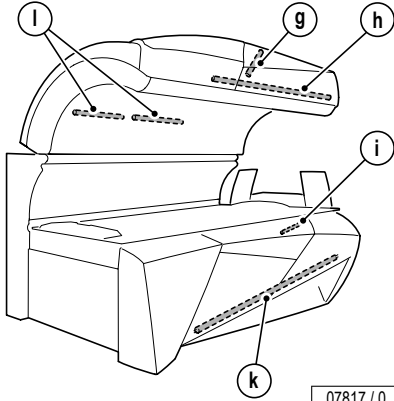

07817 / 0

g)	1 x		blue	36 W	11792-..	99
h)	1 x		blue	58 W	12063-..	99
i)	1 x		white	8 W	11839-..	101
k)	1 x		blue	36 W	11792-..	101
	with 1 x		Makrolon tube light pink		842757-..	88
l) with AQUA MIST AROMA SYSTEM						
	2 x		blue	15 W	1002103-..	88
l) without AQUA MIST AROMA SYSTEM						
	1 x		white	38 W	1002555-..	88
	with 1 x		Makrolon tube blue		1002556-..	88
1000 h						
g) - l)	6 x		S10		10047-..	88, 99, 101

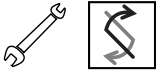

Scheduled replacement – accent lights, starters (Design Fashionpink Orange)

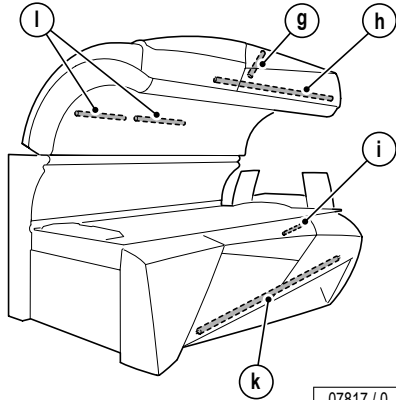

07817 / 0



g)	1 x		white	36 W	1002113-..	99
h)	1 x		white	58 W	1002089-..	99
	with 1 x		Makrolon tube yellow		1500709-..	88
i)	1 x		white	8 W	11839-..	101
k)	1 x		red	36 W	1002112-..	101
l) with AQUA MIST AROMA SYSTEM						
	2 x		blue	15 W	1002103-..	88
l) without AQUA MIST AROMA SYSTEM						
	1 x		white	38 W	1002555-..	88
	with 1 x		Makrolon tube blue		1002556-..	88
1000 h						
g) - l)	6 x		S10		10047-..	88, 99, 101



Scheduled replacement – accent lights, starters (Design Mystic Black)

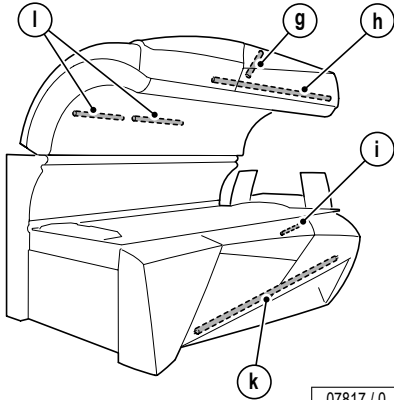

07817 / 0



g)	1 x		white	36 W	1002106-..	99
h)	1 x		white	58 W	1002108-..	99
i)	1 x		white	8 W	11839-..	101
k)	1 x		white	36 W	1002106-..	101
l)	2 x		white	15 W	1002105-..	88
1000 h						
g) - l)	6 x		S10		10047-..	88, 99, 101



Scheduled replacement – UV lamps (PRESTIGE 990 DYNAMIC POWER)

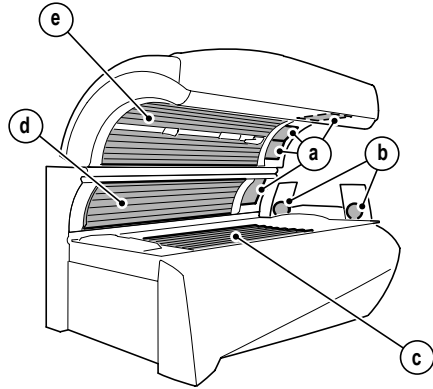

07816 / 0

500 h

a)	4 x		Ergoline Ultra	520 W	12645-..	91
b)	2 x		Ergoline Ultra	250 W	1500384-..	-

1000 h

c)	20 x		Ergoline VHP10 Dynamic Power	200 W	1004452-..	82
d)	8 x		Ergoline VHP10 Dynamic Power	200 W	1004452-..	84
e)	24 x		Ergoline VHP10 Dynamic Power	200 W	1004452-..	86
c), d), e)			Chipcard of lamp set			80



Note:

The UV high-pressure lamps used can be operated with different wattages.



UV low-pressure lamps: Clean with plain water (damp cloth).

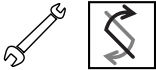

Scheduled replacement – UV lamps, starters (PRESTIGE 1100 EXTREME POWER)

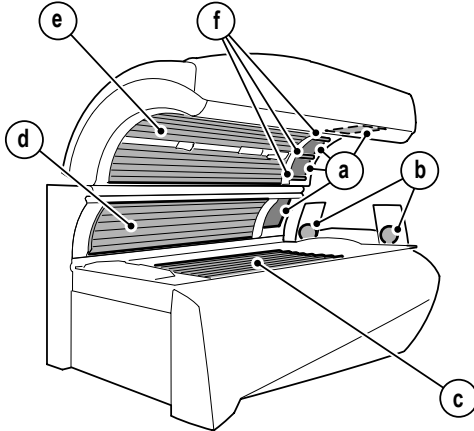

15030 / 0

Maintenance



Note:
The UV high-pressure lamps used can be operated with different wattages.



UV low-pressure lamps: Clean with plain water (damp cloth).

500 h

a)	4 x		Ergoline Ultra	520 W	12645-..	91
b)	2 x		Ergoline Ultra	250 W	1500384-..	-
f)	3 x		Ergoline MaxTan Extreme Power	15 W	13135-..	96

1000 h

c)	20 x		Ergoline VHP10 Extreme Power	200 W	1003729-..	82
d)	8 x		Ergoline VHP10 Extreme Power	200 W	1003729-..	84
e)	24 x		Ergoline VHP10 Extreme Power	200 W	1003729-..	86
c), d), e)			Chipcard of lamp set			80
f)	3 x		S12		10002-..	96



Scheduled replacement – filter panels, acrylic glass panels

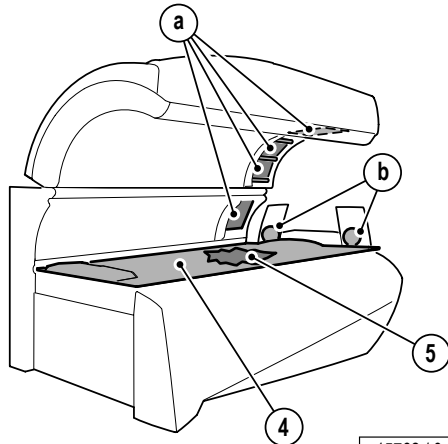

15762 / 0



Filter panels: Clean with plain water (damp cloth).

1500 h

④ 1 x



735377-..

82

3000 h

⑤ 1 x



1500339-..

82

a) PRESTIGE 990 DYNAMIC POWER

4 x



Ultra Performance 512s

1004522-..

91

a) PRESTIGE 1100 EXTREME POWER

4 x



Ultra Performance 412

1001526-..

91

b) 2 x



Ultra Performance 912

1500635-..

–

2 x



uncoated

1500160-..

–

Maintenance



Scheduled maintenance – fan



40 000 h

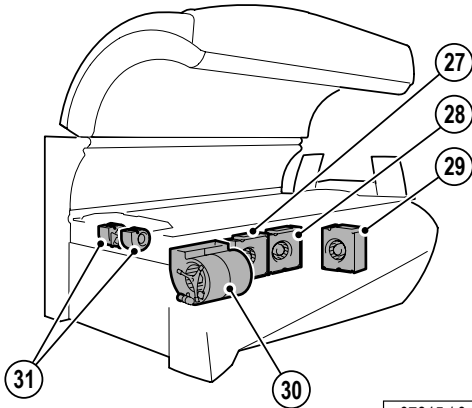

07815 / 0

②7	Body ventilator (head end)	735326-..	-
②8	Facial ventilator	735326-..	-
②9	Intermediate panel ventilator	735326-..	-
③0	Main ventilator	12873-..	-
③1	Body ventilator (feet end)	13010-..	-

Relamping / maintenance instructions

It is imperative that you, the owner and/or operator, check all components for any signs of wear which may occur through normal use.

Observe the cleaning and maintenance schedule specified in the maintenance table on Page 67 to 78.

Only replace UV low-pressure lamps with the original lamp type or with compatible lamps.

Only replace UV high-pressure lamps with the original lamp type or with compatible lamps.



WARNING!

Risk of burning!

When changing the UV low pressure lamps, the enclosed chip card must always be used! The UV low pressure lamps can only be operated at the correct power if the lamp set and chip card are exchanged simultaneously.

If the old chip card is left in the unit, the new lamp set is operated at too high power and the user may suffer heavy burns!

Should you require any assistance or need additional information, please call Global Service USA at (800) 445-0624, Monday through Friday 7:00 a.m. - 7:00 p.m. CT, Saturday 8:00 a.m. to 3:00 p.m.



CAUTION – Damage due to improper maintenance!

Improper maintenance can cause the device to be damaged or to become unusable.

- Always comply with the specified maintenance intervals.
- Follow the cleaning instructions.
- If the maintenance intervals for the UV lamps are exceeded or incompatible UV lamps are installed, the share of harmful UVB radiation may increase. Sunburn and other skin damage may result.



WARNING!

Danger: of burns from hot lamps and device parts!

If the tanning device was operated before being switched off and opened, lamps and housing parts may be hot.



- Before replacing lamps or other spare parts, wait until lamps and metal parts of the device have cooled down sufficiently.



Danger of pinching!

When opening and closing the tray, panels and covers, you can pinch your fingers.

Inserting the chip card for the new set of lamps

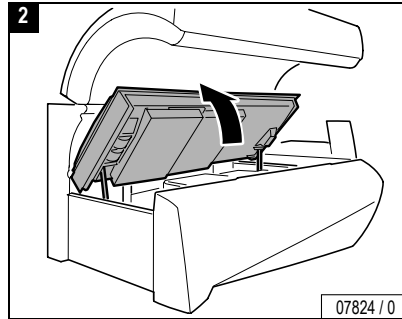
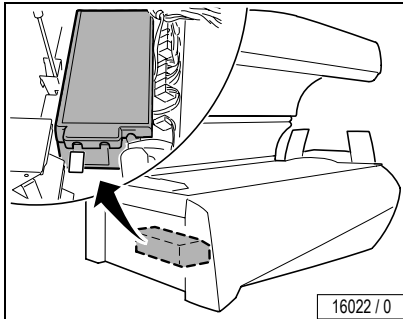
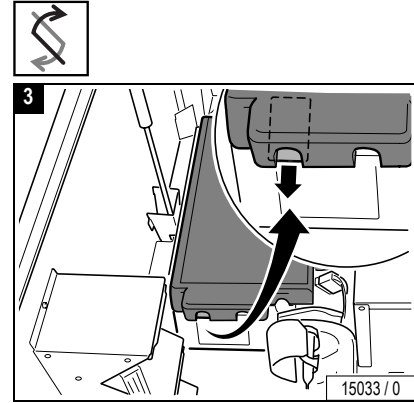
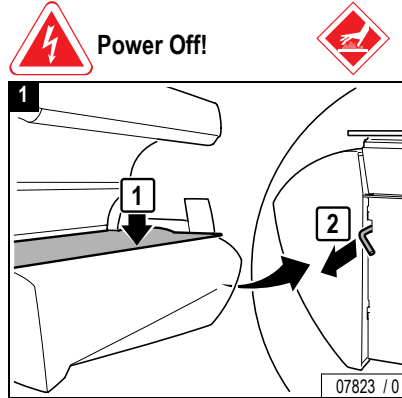
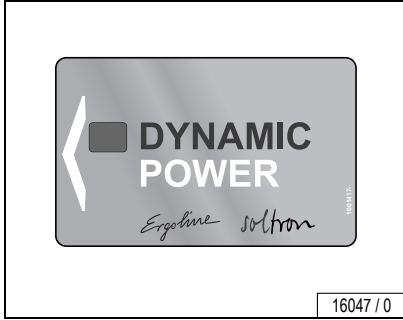
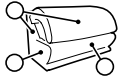
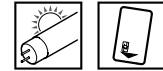

Maintenance 

...

Inserting the chip card for the new set of lamps

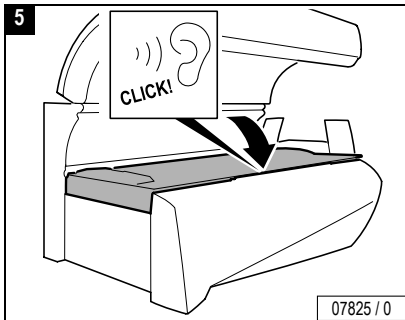
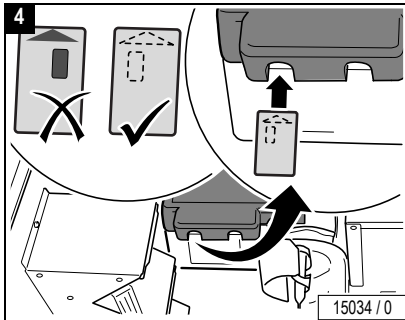

Maintenance 



Cleaning/replacing UV low-pressure lamps, sunbed base

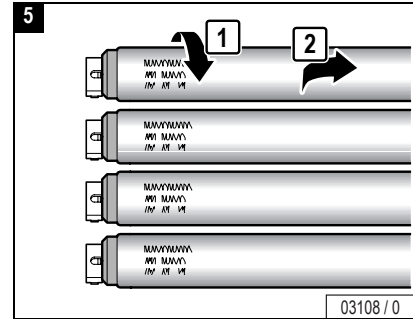
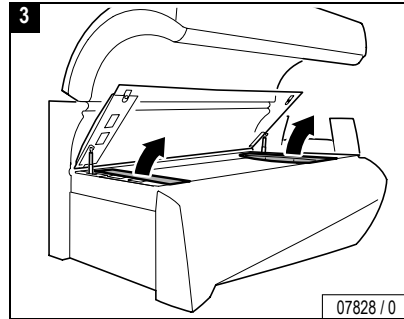
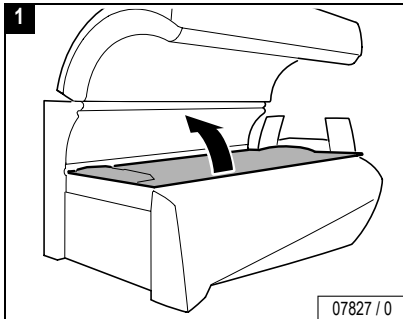
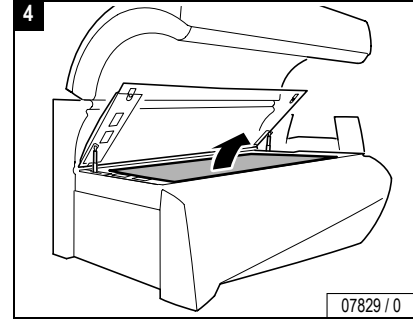
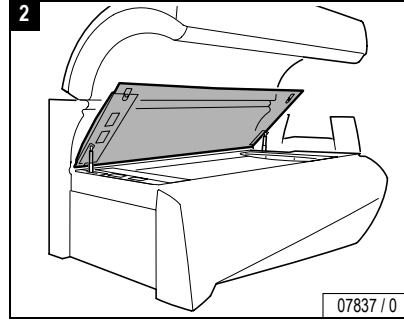
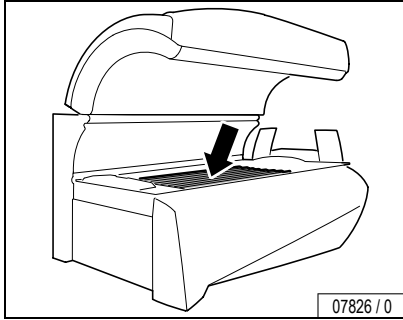
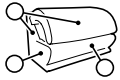

Maintenance

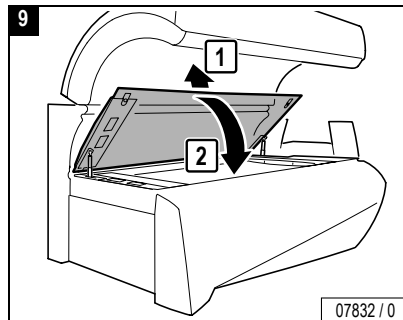
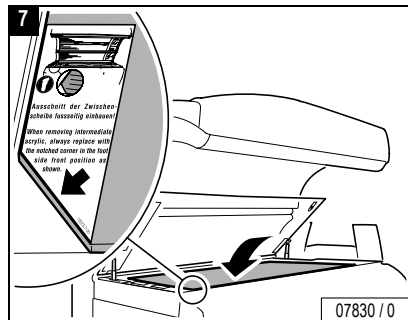
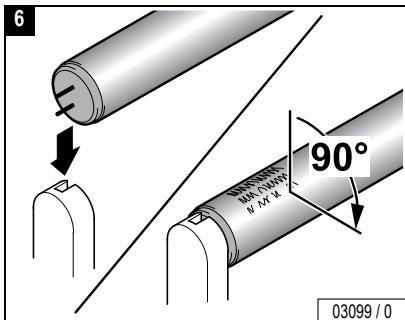

Note!

Inserting the chip card for the new set of lamps, see Page 80.

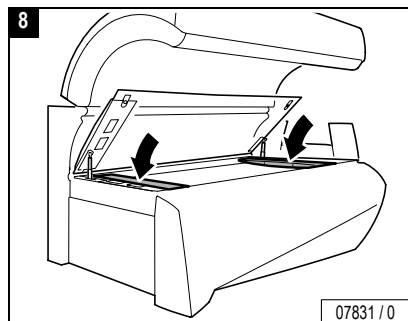

Cleaning/replacing UV low-pressure lamps, side section

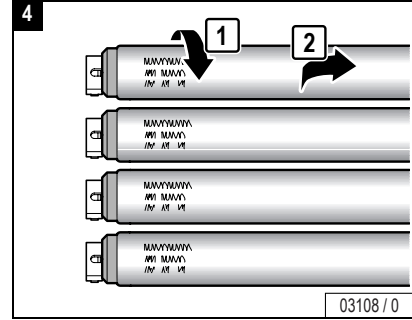
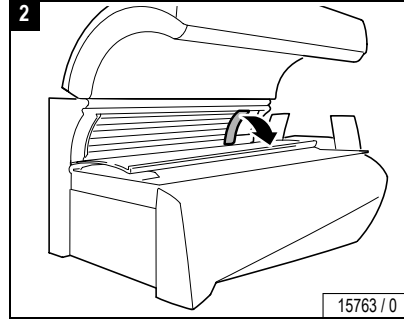
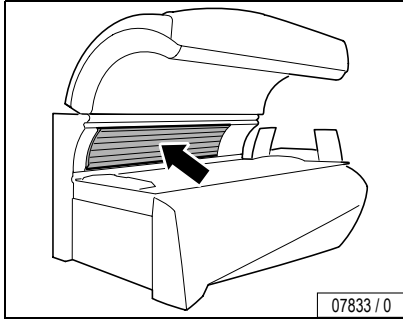
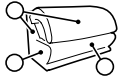

Maintenance



Power Off!

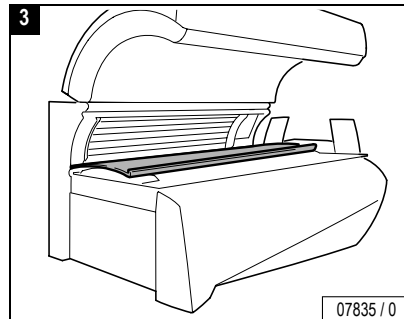
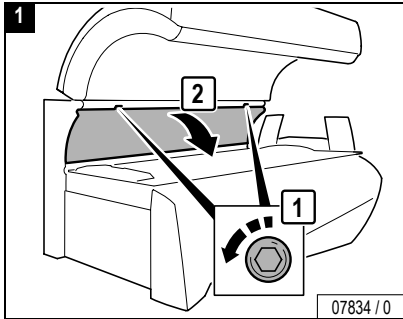

...

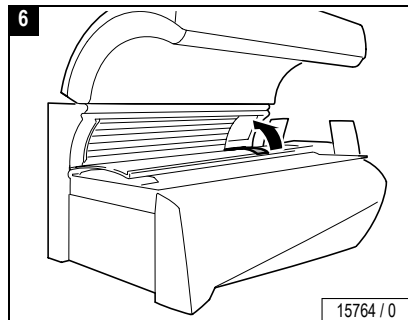
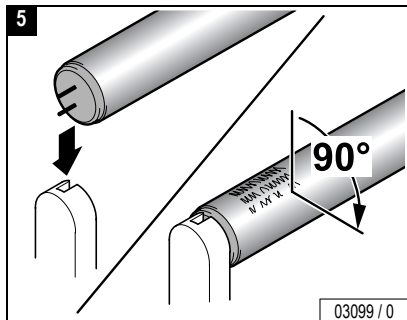

Note!

Inserting the chip card for the new set of lamps, see Page 80.

Close:

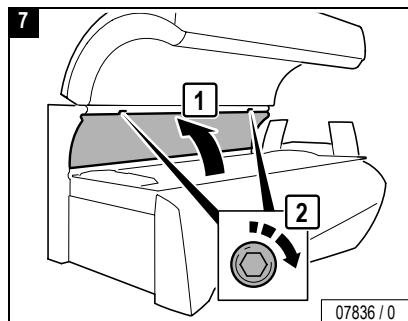

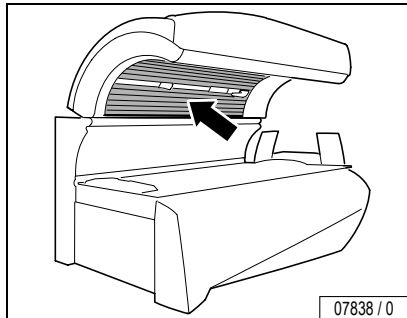
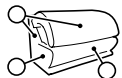

Caution!

The canopy panel may break if allowed to fall or if pressure is exerted on the reverse side of an open acrylic glass panel. Such failure is not covered by manufacturer's warranty.

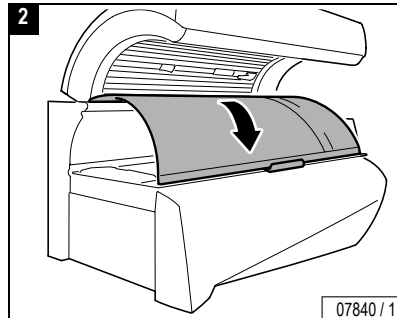

Power Off!

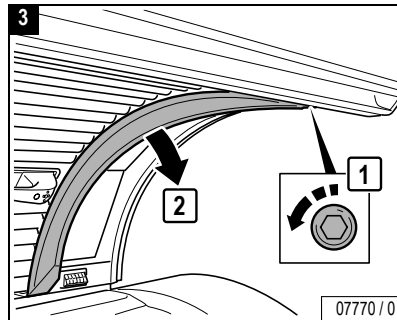
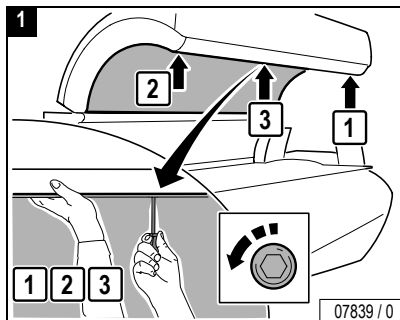

Danger of injury from the canopy panel!

WARNING!

The canopy panel is heavy and falls down by itself after unscrewing the 3 screws.

- Support canopy panel.
- Loosen screws in the specified order.

Cleaning/replacing UV low-pressure lamps, side section

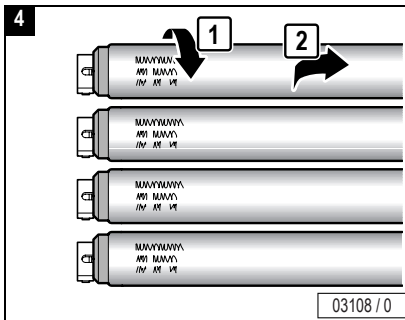

Note!

Inserting the chip card for the new set of lamps, see Page 80.

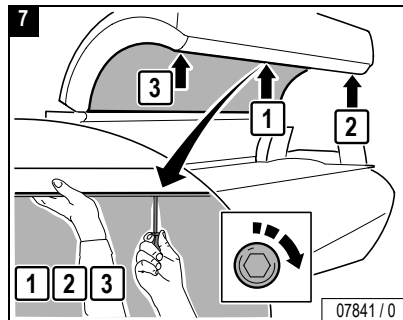
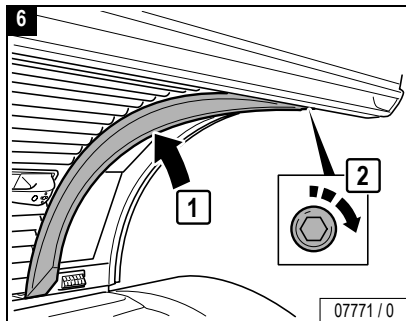
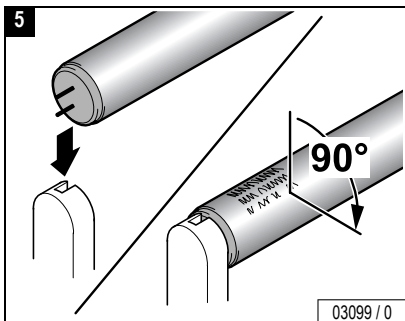

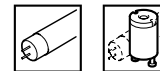

Maintenance 

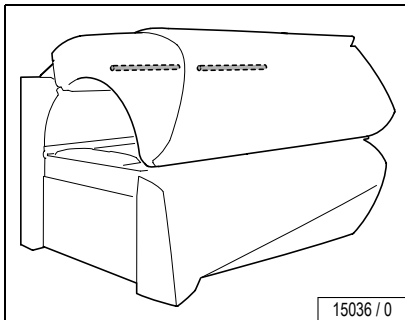
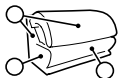

WARNING!

Danger of injury from the canopy panel!

The canopy panel is heavy and falls down by itself after unscrewing the 3 screws.

- Support canopy panel.
- Loosen screws in the specified order.



Caution!

Canopy panel may break if allowed to fall or if pressure is exerted on the reverse side of an open acrylic glass panel. Such failure is not covered by manufacturer's warranty.



Power Off!

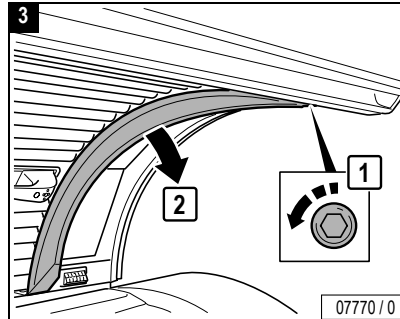
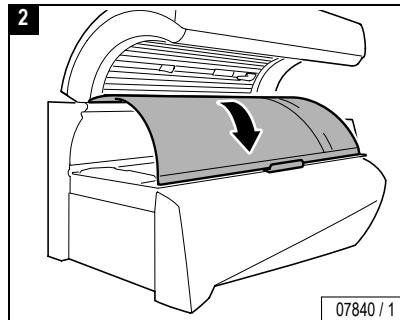
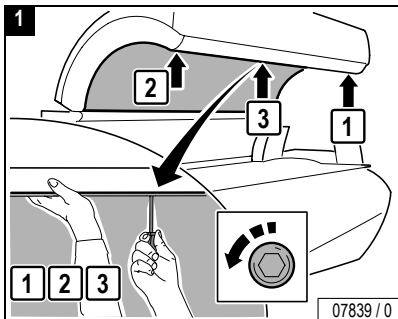

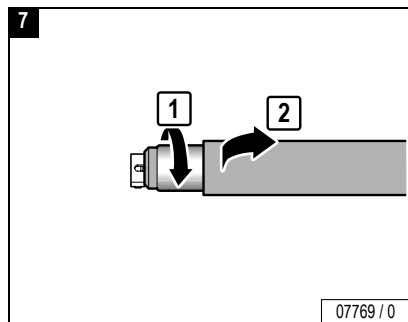
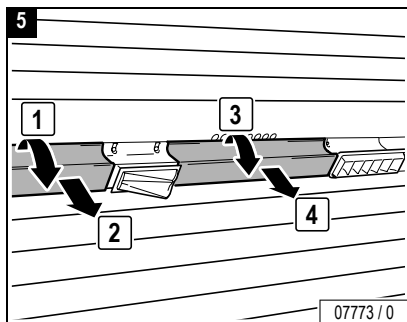
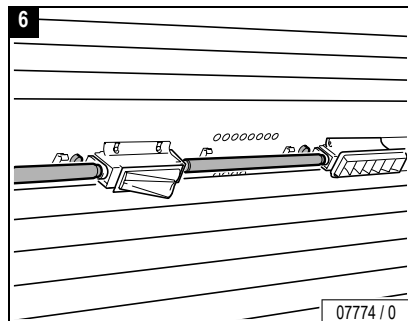
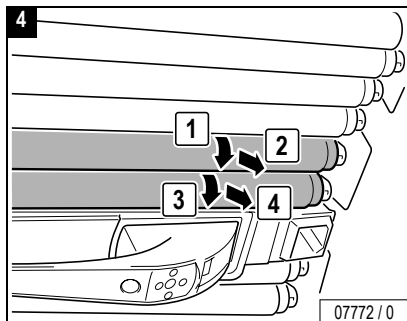

if available

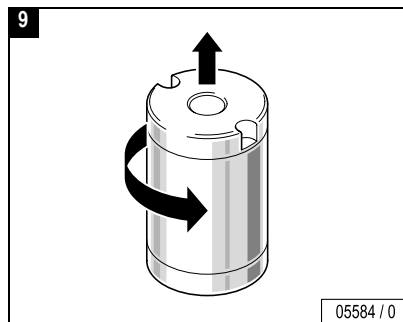
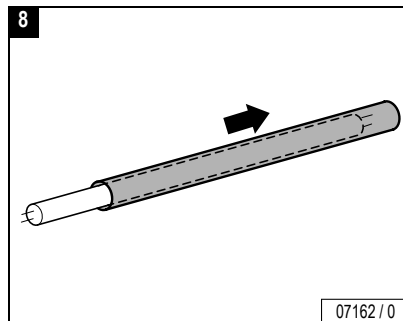

...

if available

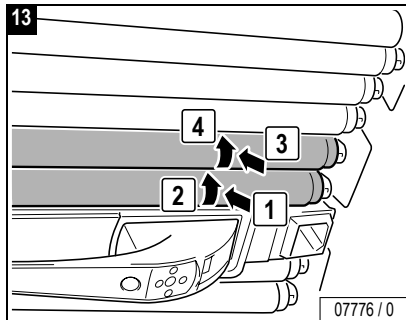
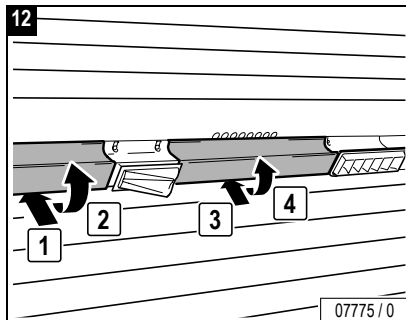
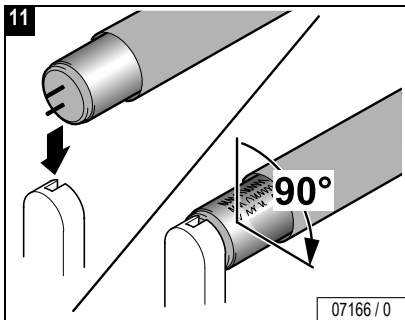
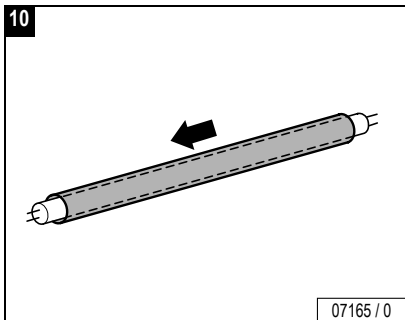

Close:

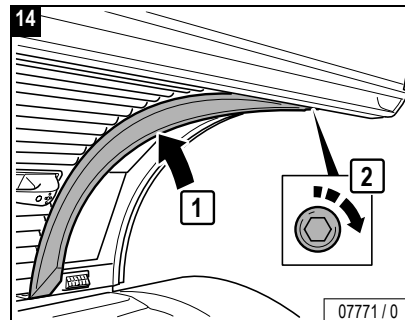

Close:

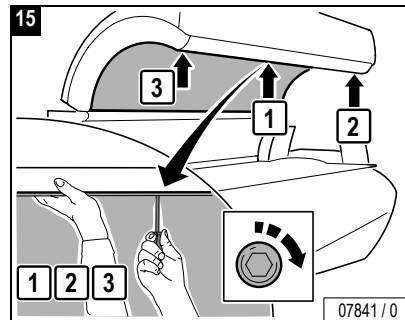

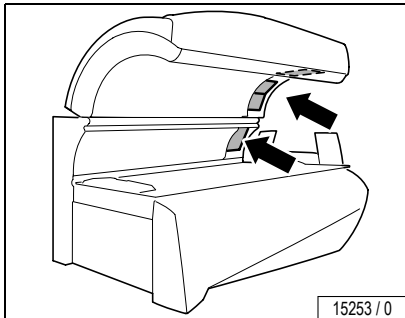
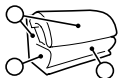

Power Off!



Caution! Risk of breakage and scratching!



Do not open canopy and side section at the same time otherwise the panels scratch against each other. Replace one after the other.



WARNING!

Danger of injury from the canopy panel!

The canopy panel is heavy and falls down by itself after unscrewing the 3 screws.

- Support canopy panel.
- Loosen screws in the specified order.



Caution!

Canopy panel may break if allowed to fall or if pressure is exerted on the reverse side of an open acrylic glass panel. Such failure is not covered by manufacturer's warranty.

Open: side section panel:

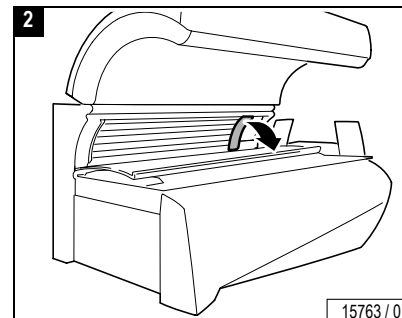
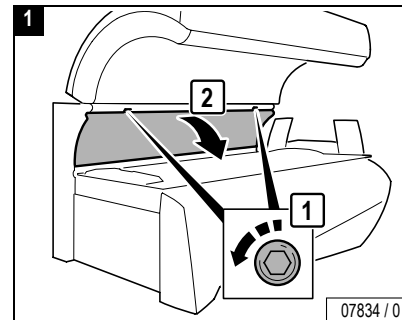

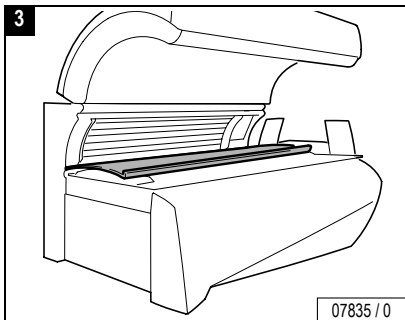

Open: canopy panel:

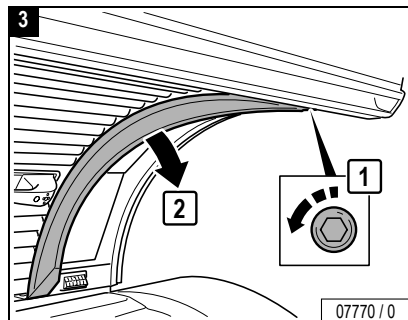
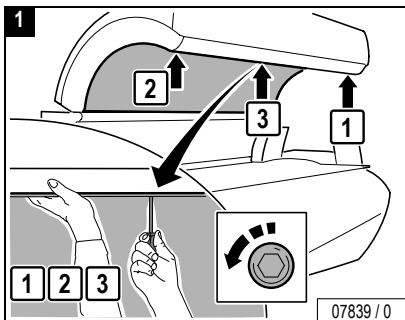
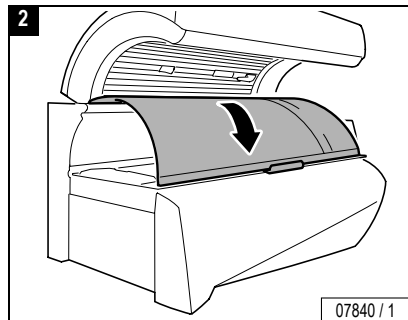

Clean/replace: UV high-pressure lamps and filter panels



Note:

In the case of the PRESTIGE 1100 EXTREME POWER, the UV low-pressure lamps of the facial tanner must be removed before cleaning/replacing the UV high-pressure lamps and filter panels in the canopy, see Page 96.

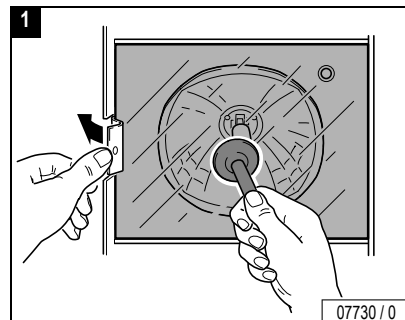

...

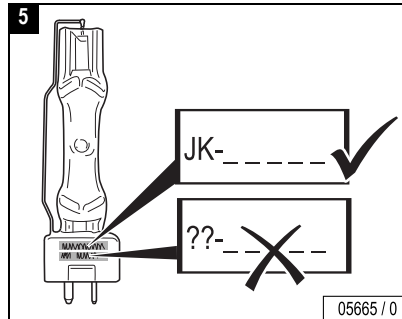
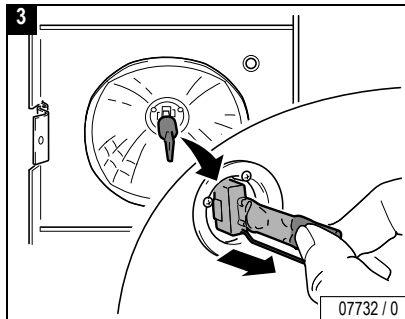
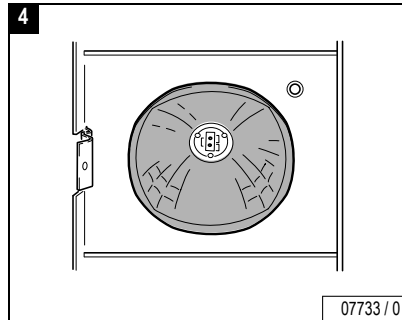
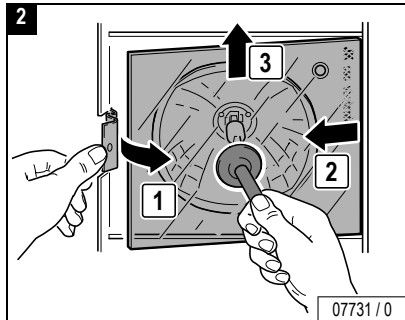

DANGER! Fire hazard!

High pressure lamps that have not been approved by Ergoline can explode. Hot lamp components can set other parts on fire. People can be killed or severely injured due to smoke and fume inhalation.

- Only fit high pressure lamps recommended by Ergoline.
- Clean the inside of the device regularly. Foreign materials could be flammable!

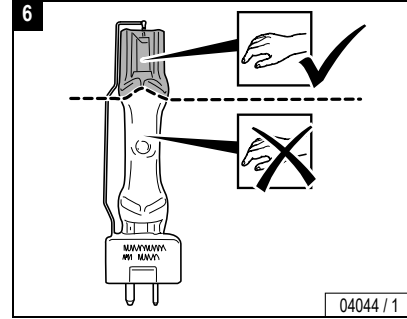

Cleaning/replacing UV high-pressure lamps/filter panels, canopy and side section



CAUTION!

Do not touch the glass bulbs of the UV high-pressure lamps with your bare fingers! Remove soiling thoroughly.



– Only touch new UV high-pressure lamp on the gripping surface – see Figures 6 and 7.



– Check safety switch.

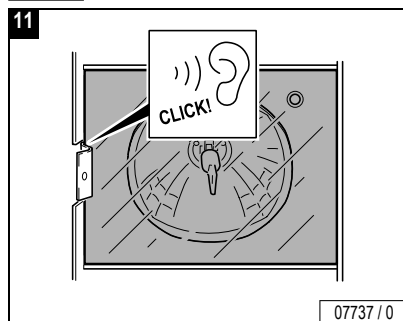
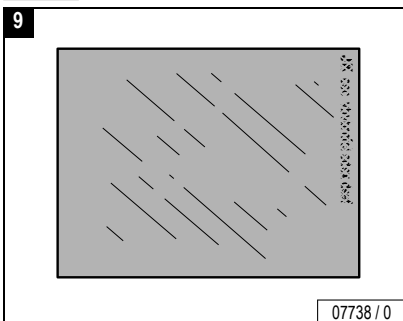
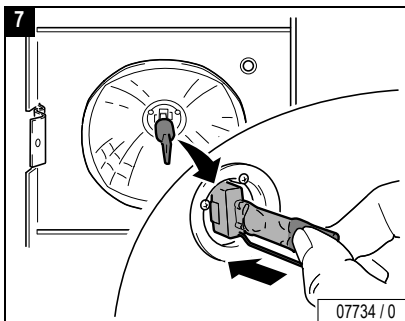
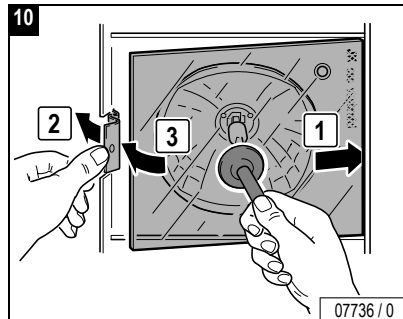
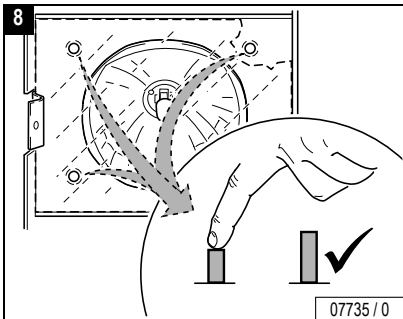

Close: side section:

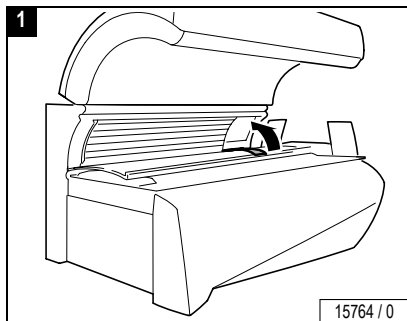

Close: canopy:

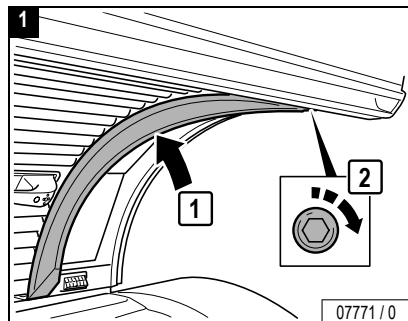

Close:

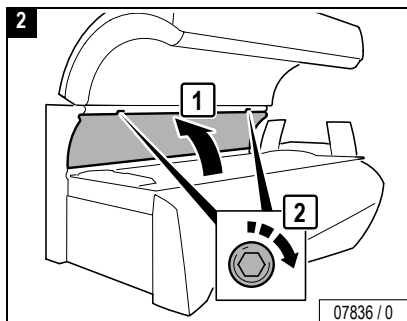

Close:

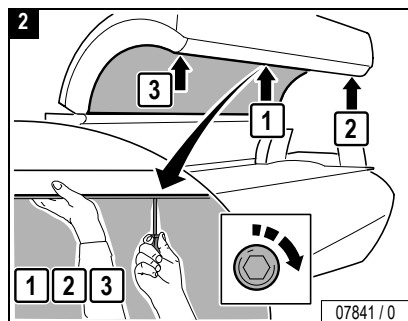

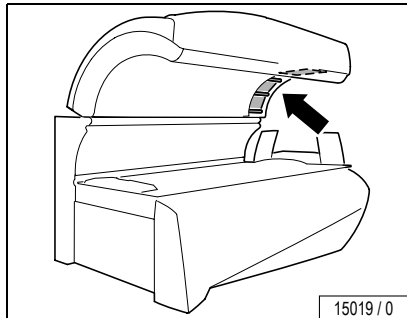
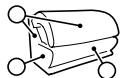

Caution!

Canopy panel may break if allowed to fall or if pressure is exerted on the reverse side of an open acrylic glass panel. Such failure is not covered by manufacturer's warranty.

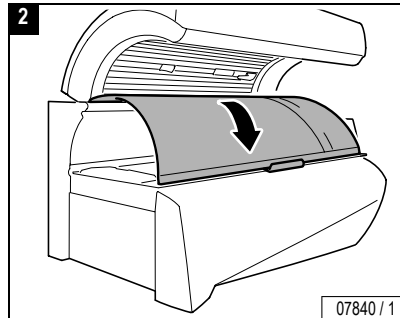

Maintenance 



Danger of injury from the canopy panel!

WARNING!

The canopy panel is heavy and falls down by itself after unscrewing the 3 screws.

- Support canopy panel.
- Loosen screws in the specified order.



Power Off!

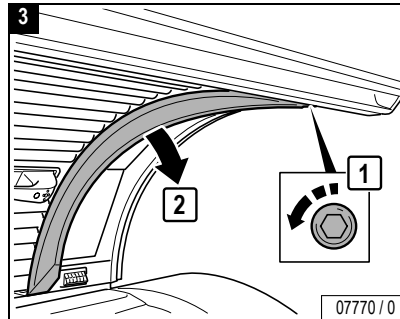
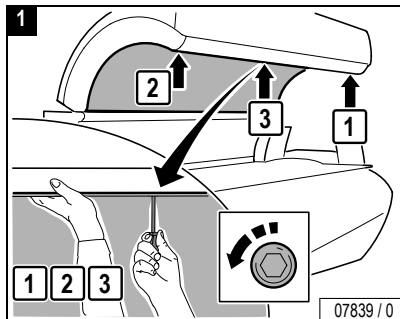

...

PRESTIGE 1100: Cleaning/replacing the UV low-pressure lamps in the facial tanner

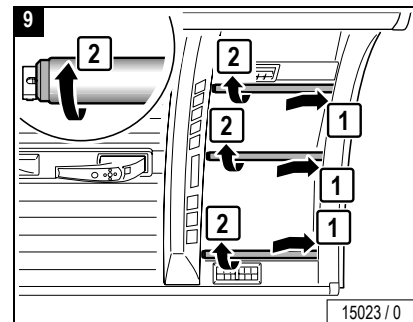
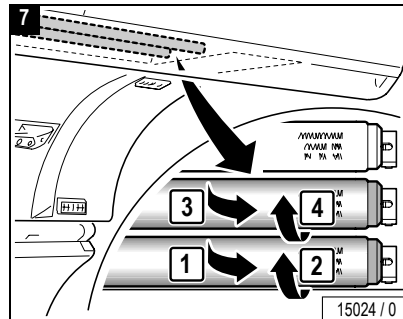
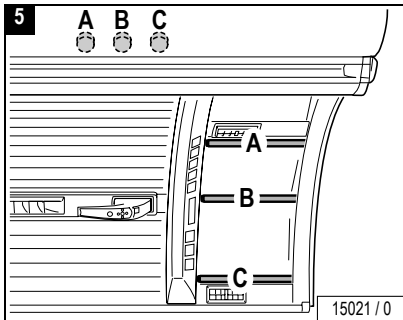
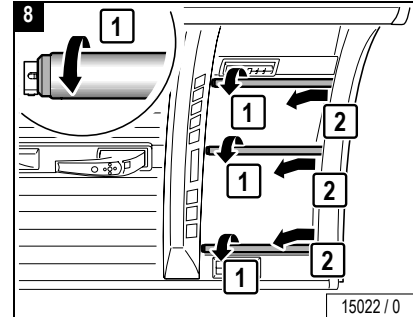
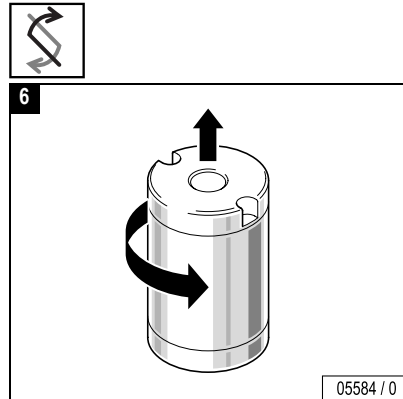
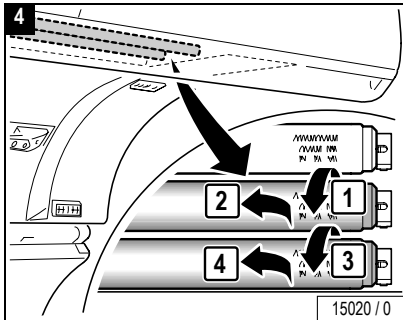

Close:

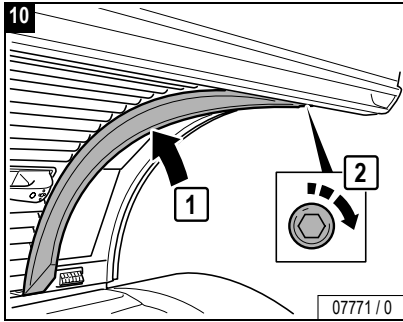

Close:

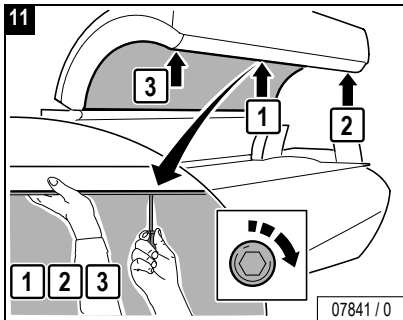

Maintenance 



Cleaning/replacing accent lights, canopy

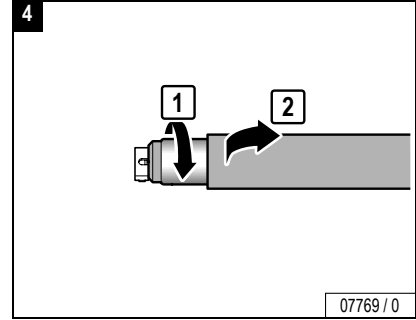
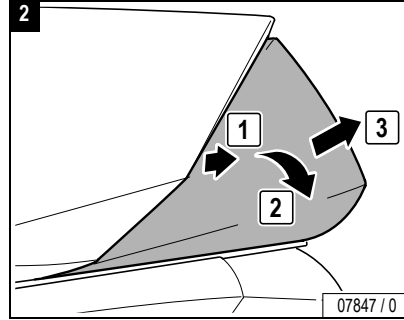
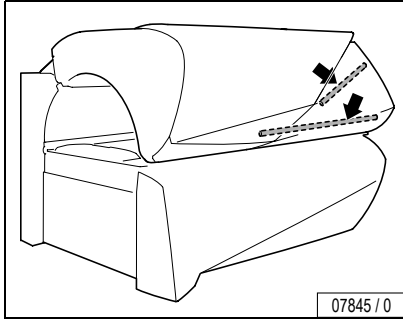
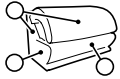
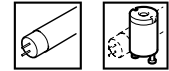

Power Off!

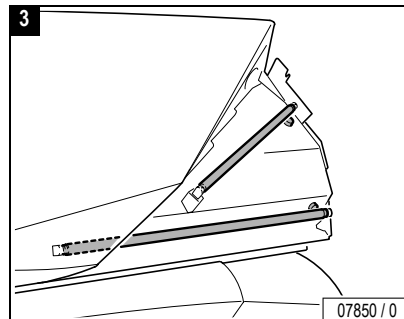
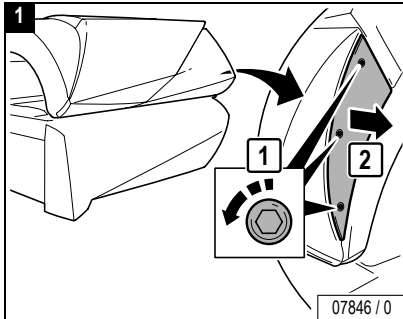

if available

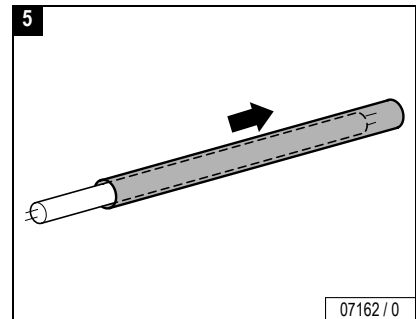

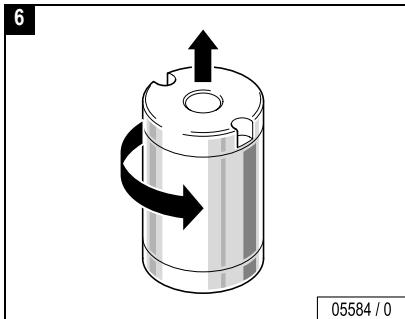

Maintenance

...

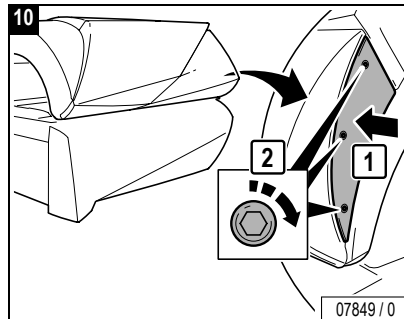
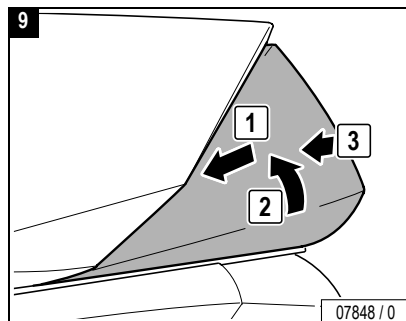
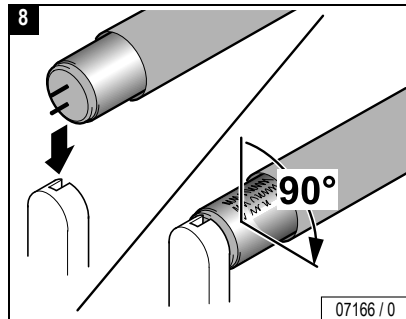
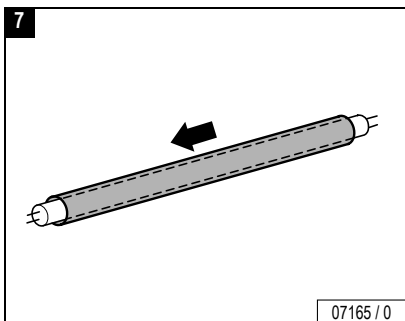

if available



Maintenance 

Cleaning/replacing accent lights, front panel

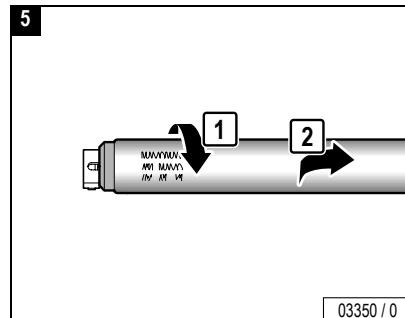
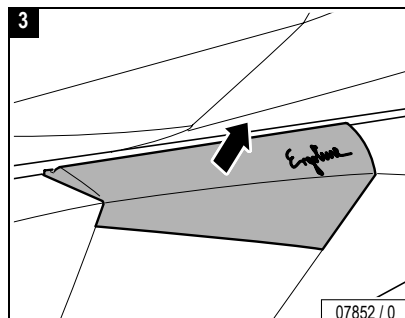
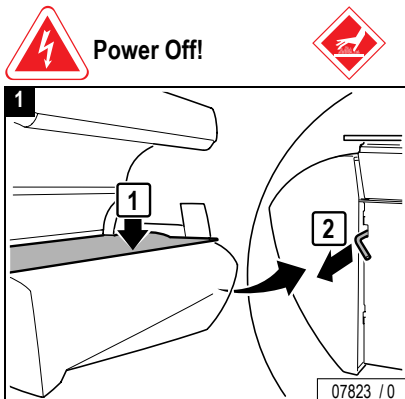
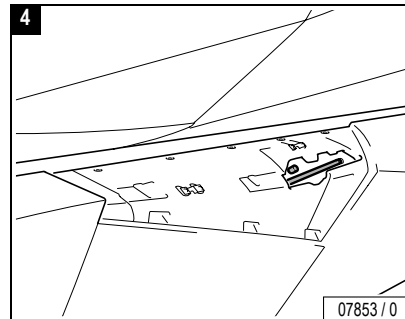
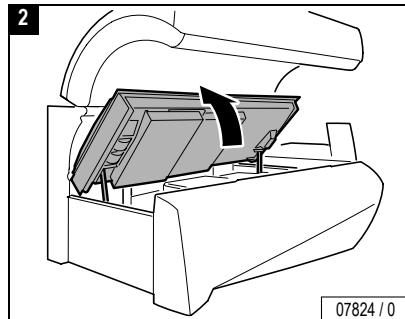
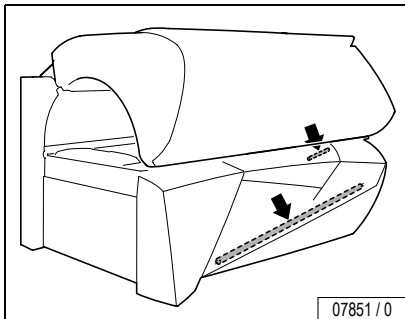
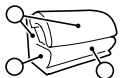
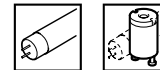

Cleaning/replacing accent lights, front panel

Maintenance 

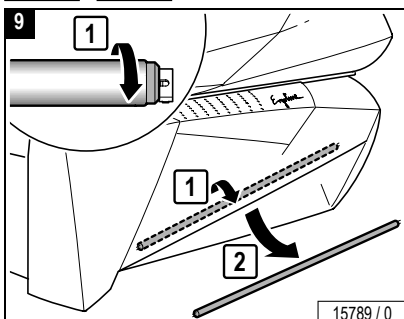
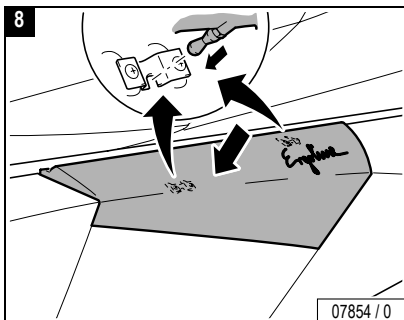
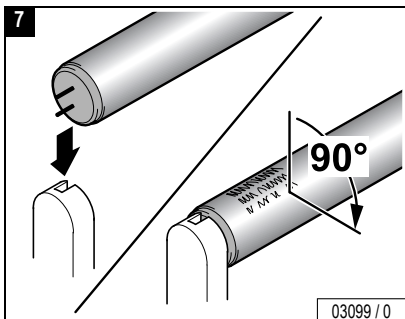
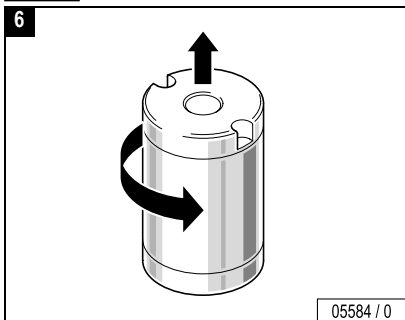

if available

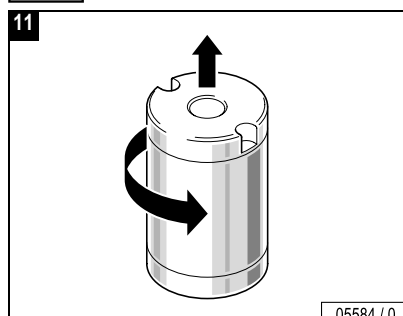
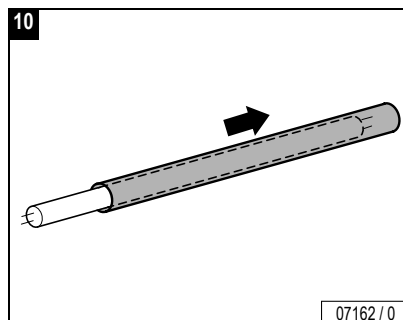

...

Cleaning/replacing accent lights, front panel

if available

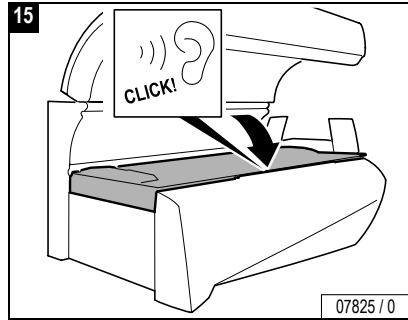
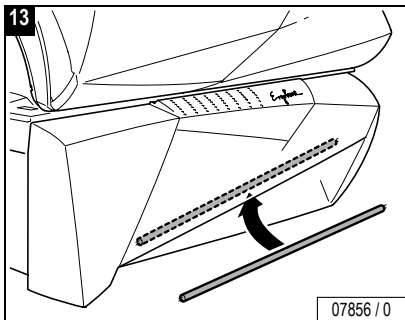
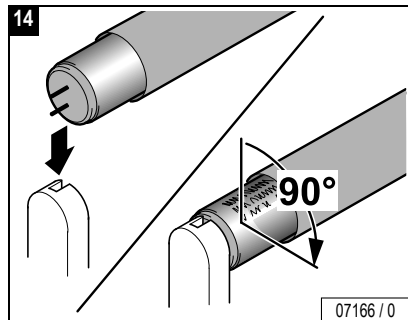
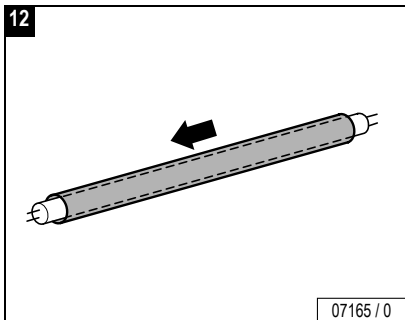

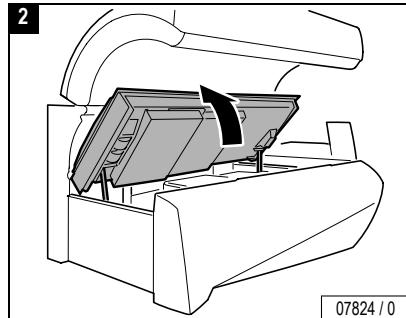
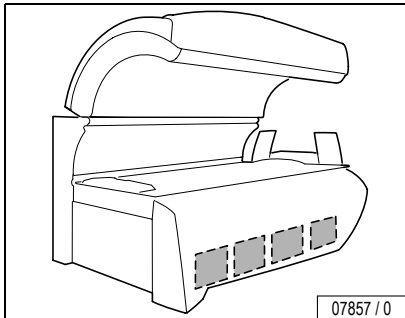
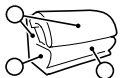

Cleaning filters, sunbed base

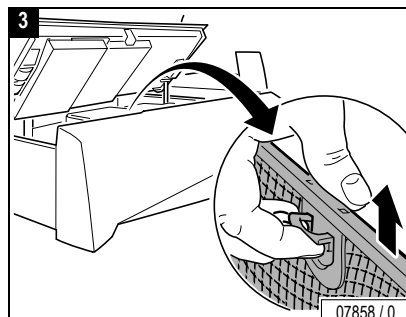
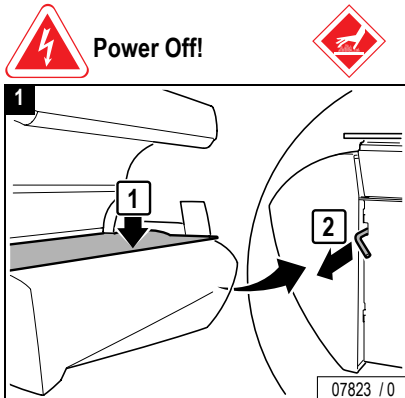
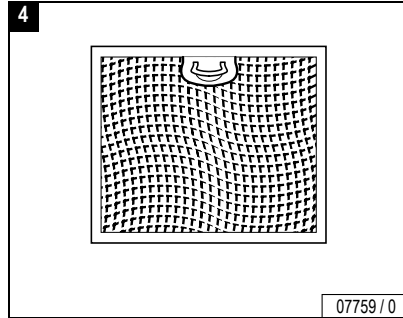

Hand-wipe lightly, dry or with water, or use a vacuum cleaner.



 **Power Off!** 

 **Attention! The system can be damaged by moisture!**
When re-assembling, the cleaned filter mats must be dry.

Maintenance 

...

Cleaning filters, sunbed base

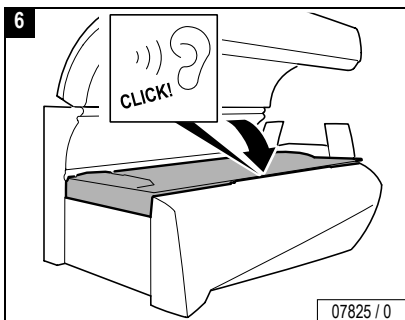
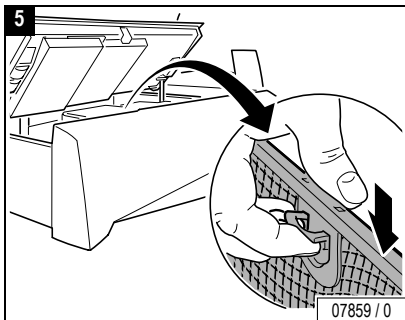

Cleaning/replacing filter mats, canopy

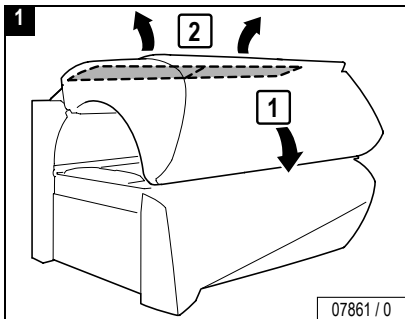
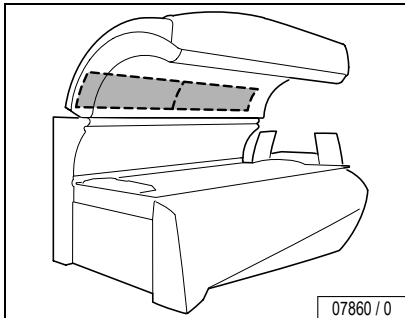
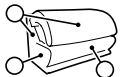

Rinse with water or replace.

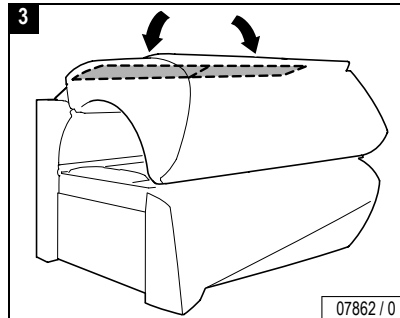
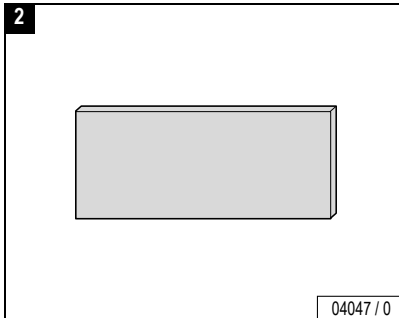

Attention! The system can be damaged by moisture!

When re-assembling, the cleaned filter mats must be dry.

Maintenance



Temptronic: Emptying condensate tank, cleaning/replacing the filter mats, cleaning the cooling fins





Regelmäßige Sichtprüfung!
Regular visual check!
Contrôle visuel régulier!

Gefahr von Geräteschäden!
Risk of damage to equipment!
Risque de détérioration de l'appareil!

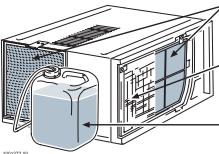

Filtermatten reinigen!
Renew filter mats!
Nettoyer les mats filtrants!

Kühlrippen reinigen!
Clean cooling fins!
Nettoyer les barres de refroidissement!

Kondensatbehälter entleeren!
Empty condensation container!
Vidanger le réservoir à condensation!

161073-00

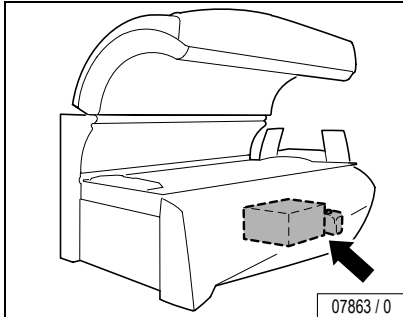
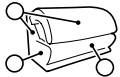

Attention! Risk of damage to the system!

Check the filter mats and the cooling fins on the air conditioner regularly and clean as necessary.



Power Off!

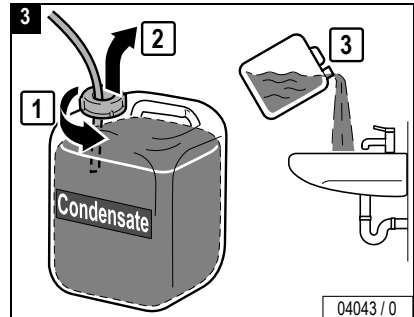
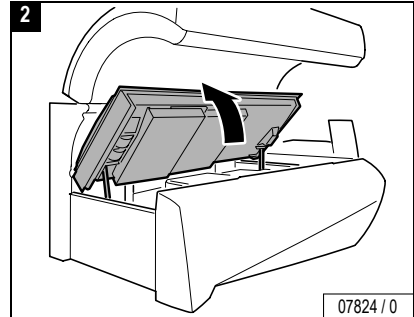
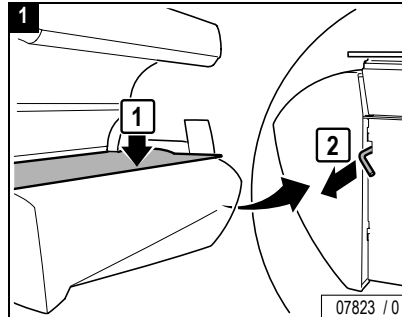

Maintenance

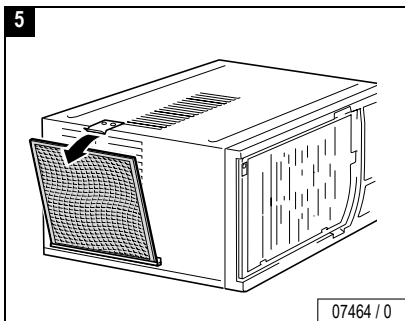
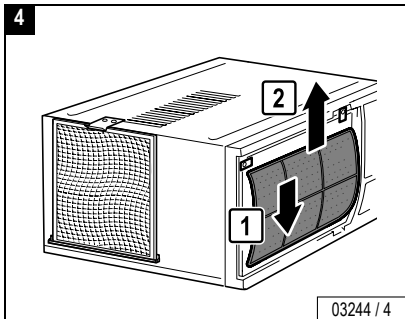

Clean carefully (vacuum or wash) or replace.

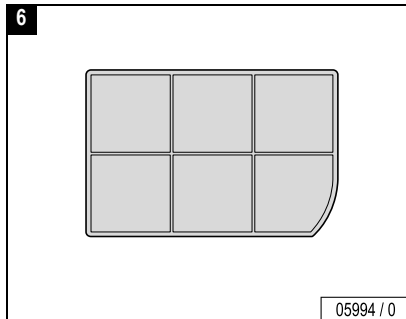

Hand-wipe lightly, dry or with water, or use a vacuum cleaner.

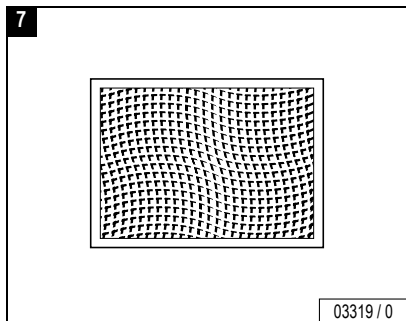

Clean carefully.

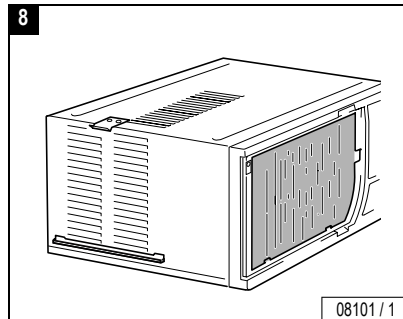

Attention! The system can be damaged by moisture!

When re-assembling, the cleaned filter mats must be dry.

...

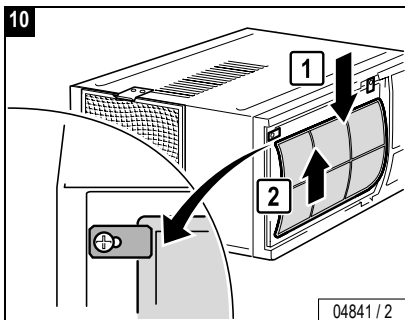
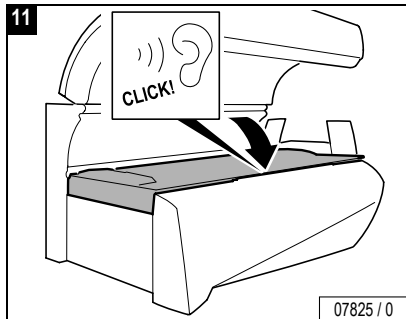
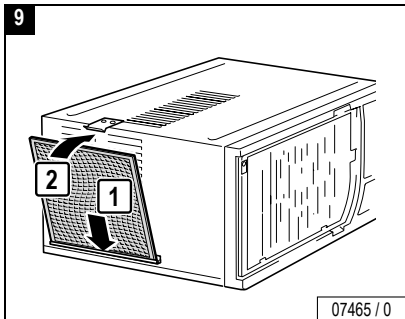

Temptronic plus: Emptying condensate tank, cleaning/replacing the filter mats, cleaning the cooling fins

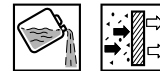

Maintenance 

ACHTUNG! Hier oben!
Falls Klimagerät gekippt, vor Inbetriebnahme 8 Stunden in Normalstellung stehen lassen, wegen Rücklauf der Kälteflüssigkeit in das Rohr.

ATTENTION! This side up!
In case air conditioner unit was toppled over, let it 8 hours in home position before initiation, because of the return of the refrigerant.

GEFAHR
Bei geöffnetem Gerät nicht spannungsfrei!

DANGER
Voltage is not switched off, when sunbed is opened.

Regelmäßige Sichtprüfung!
Regular visual check!
Contrôle visuel régulier!

Gefahr von Geräteschäden!
Risk of damage to equipment!
Risque de détérioration de l'appareil!

Abdeckung entfernen!
Remove cover!
Éliminer la couverture!

Filtermatten reinigen!
Renew filter mats!
Nettoyer les mats filtrants!

Kühlrippen reinigen!
Clean cooling fins!
Nettoyer les barres de refroidissement!

Kondensatbehälter entleeren!
Empty condensation container!
Vidanger le réservoir à condensation!

1002243-01

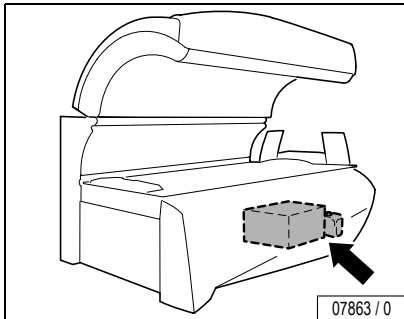
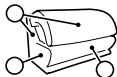

Attention! Risk of damage to the system!

Check the filter mats and the cooling fins on the air conditioner regularly and clean as necessary.



Power Off!

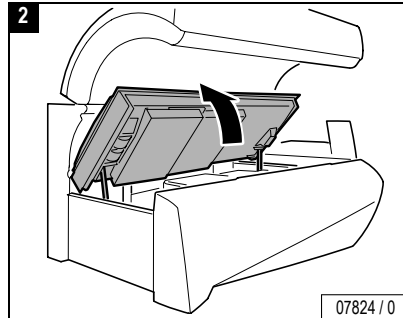
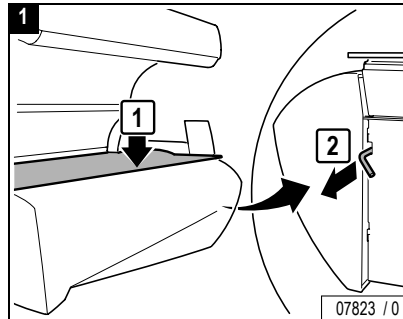

...

Temptronic plus: Emptying condensate tank, cleaning/replacing the filter mats, cleaning the cooling fins

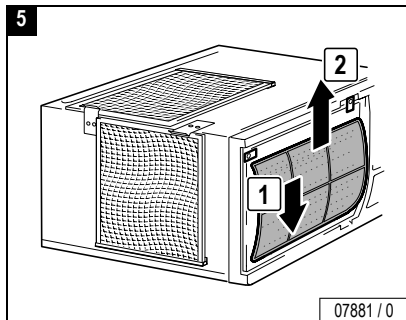
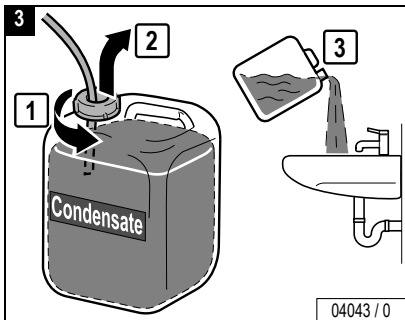

Clean carefully (vacuum or wash) or replace.

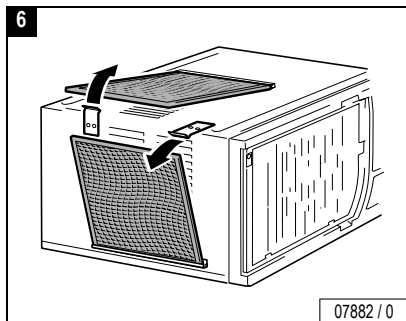
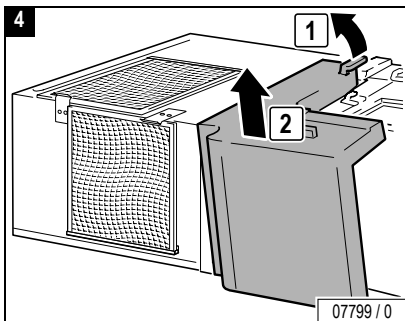
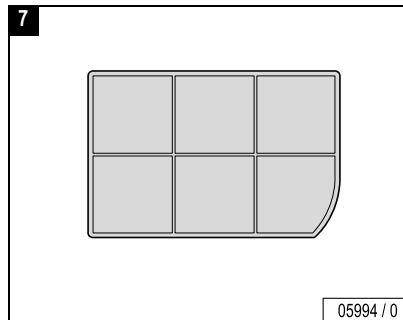

Hand-wipe lightly, dry or with water, or use a vacuum cleaner.

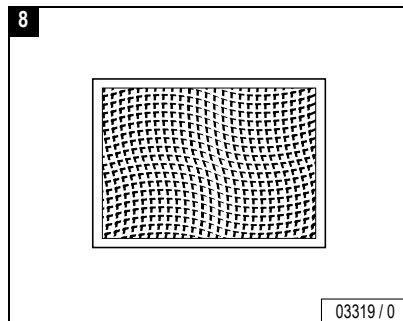

Maintenance



Clean carefully.

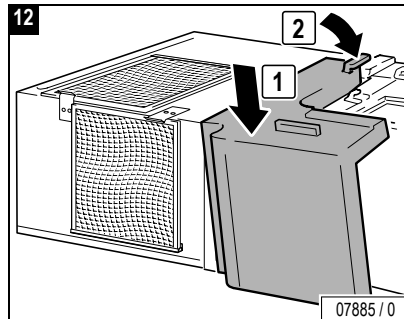
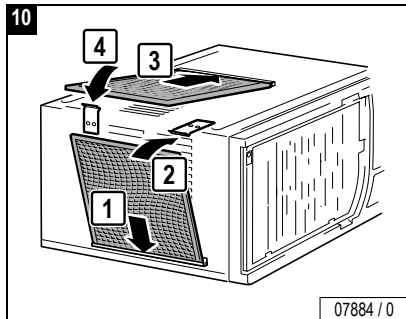
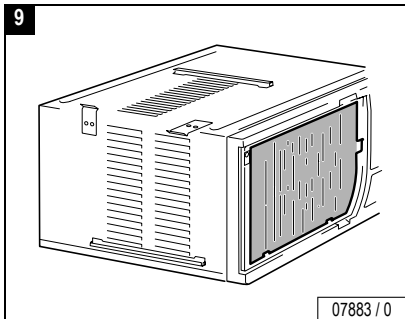

Attention! The system can be damaged by moisture!

When re-assembling, the cleaned filter mats must be dry.

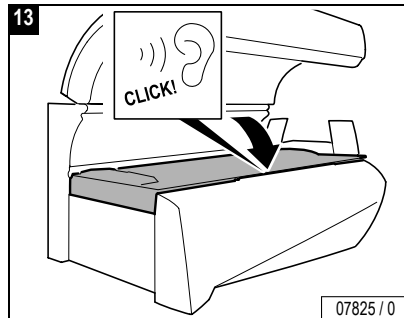
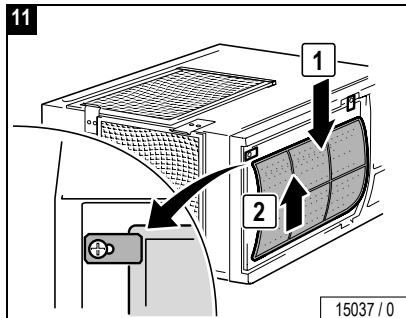

Replacing AROMA container

AROMA

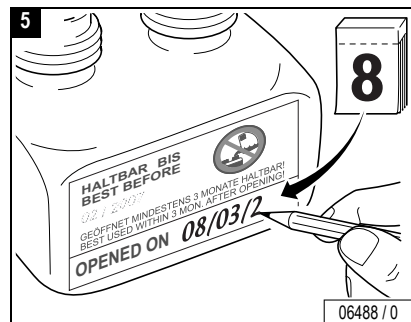
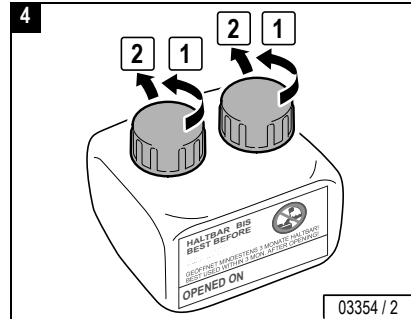
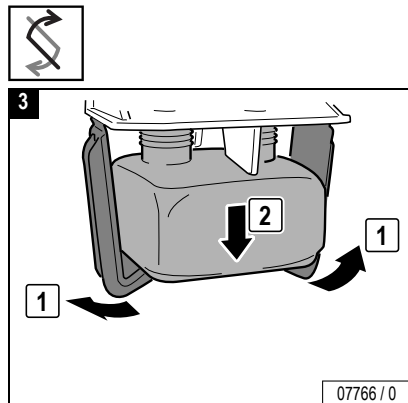
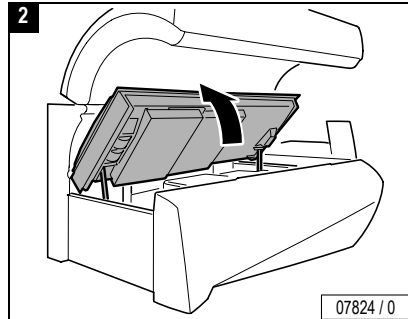
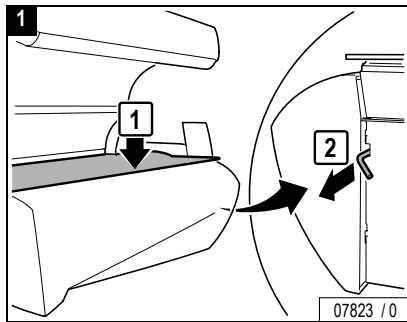
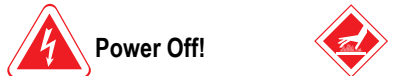
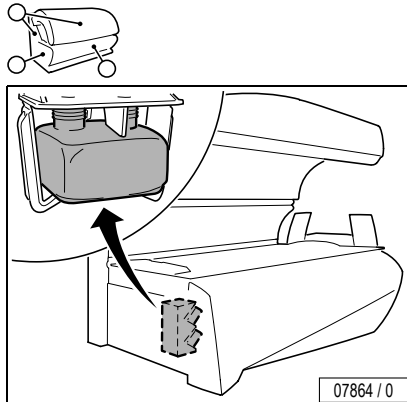

Maintenance 

Replacing AROMA container

Maintenance 

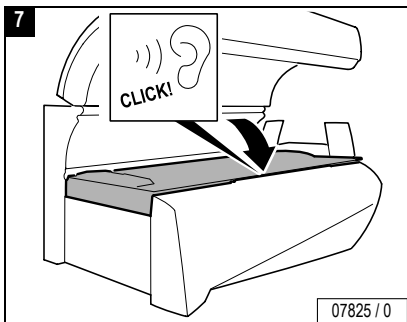
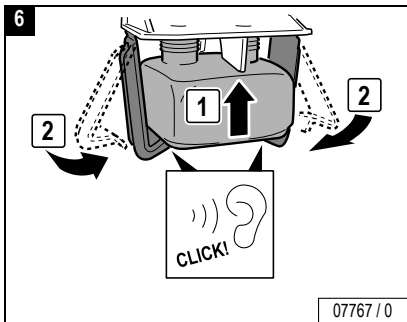

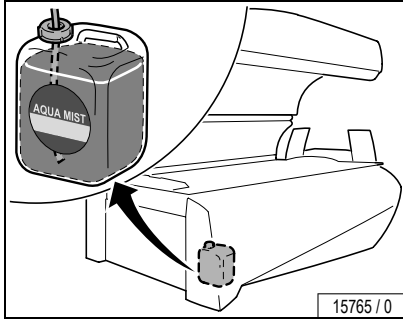
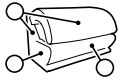

15765 / 0



Power Off!

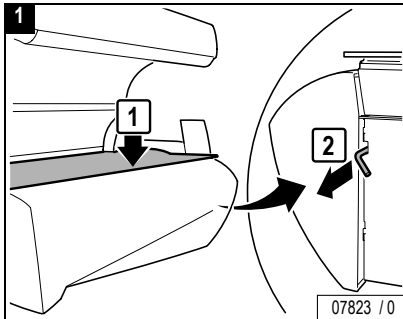

07823 / 0

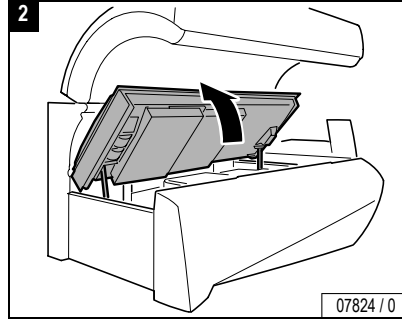

07824 / 0



WARNING!

Health hazard!

Impurities in the AQUA MIST can present a health hazard.

- Use only original Sun Ergoline AQUA MIST!
- Replace the entire canister.
- Do not top up or mix with tap water or other liquids!
- Do not swallow!

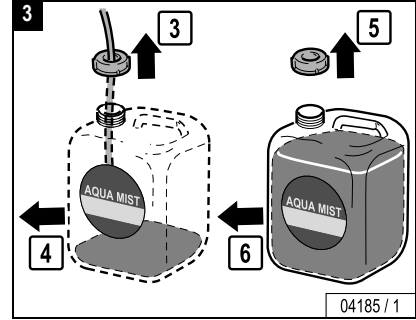

04185 / 1

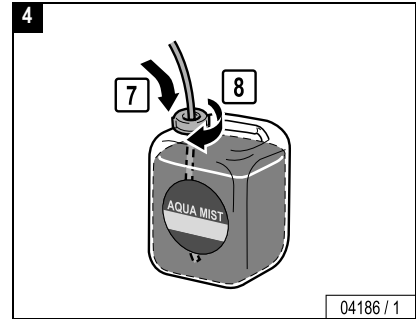

04186 / 1



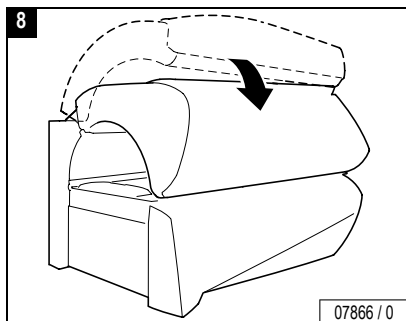
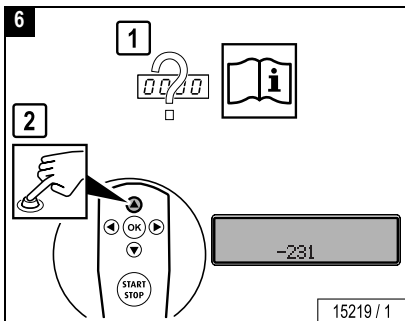
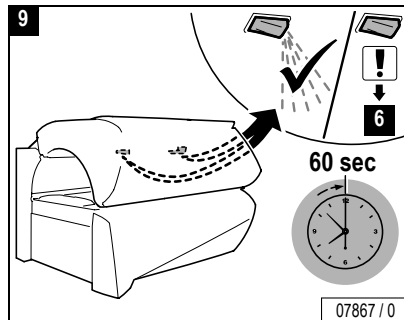
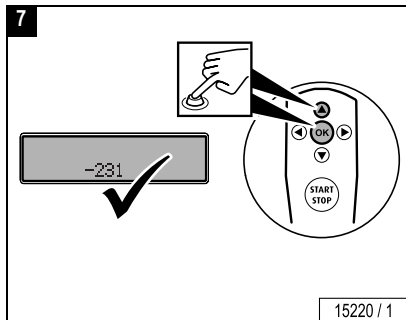
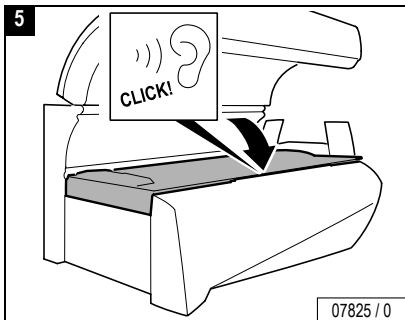

Note:

For venting after canister replacement you must enter presetting mode and choose function 231 (see separate instructions "Presettings", Order no.: 100 1971)



Index

A

Accent lights	
Cleaning/replacing	99, 101
Maintenance schedule	71, 72, 73, 74
Accessories	18, 25
Acoustic level	64
Acrylic glass, cleaning	21
Activating AQUA MIST Impulse	44
Air conditioning unit, filter mats	107, 110
Allergies	22
AQUA MIST	
Body nozzle	49
Head nozzle	47
Replacing canister	115
AQUA MIST comfort program,	
switching on and off	45

AROMA

Replacing container	113
Switching on and off	51

B

Bed tolerance in room	63
Body cooling, regulating	40

C

Canopy	
Interior lighting	88
Replacing UV-lamps	86
Care	20
Changing music track	58
Changing studio music channel	58
Chip card of lamp set	79, 80
Cleaning	21
Cleaning schedule	67
Conformity mark	62
Connecting an MP3 player	60
Contact lenses	22
Container AROMA	113
Cooling fins, air condition	107, 110

D

Description of tanning device	24
Disinfection	21
Disposal of lamps	20

E

Ending tanning session	31
Environmental protection	20
Error codes	123

F

Facial cooling, regulating	42
Facial tanner	
Regulating	33
Replacing high-pressure lamps	91
Fault codes	123
Filter in sunbed base	104
Filter mats	
Air conditioning unit	107, 110
Canopy	106
Filter panels, maintenance schedule	75, 76, 77
Filters in sunbed base	104
Frequency	62
Fusing	62

G

Glasses	22
Global Service USA, address	3
Guidelines	18

H

Humidity	64
----------------	----

Index

I					
Intended use	11	Preparation time	30	T	
Interior lighting, replacing	88	Proper use	11	Tanning	30
Interrupting tanning session	31	Protective goggles	22, 30	Tanning instructions	22
L		R		Technical data	62
Lamps, disposal	20	Relamping	79	Temptronic, adjust coolness	38
Load, maximum	63	Replacing the chip card for the new set of lamps	80	Timer	30
M		Room temperature	64	Troubleshooting	123
Maintenance	66	Running time of accent lights	32	U	
Maintenance and care	20	S		Using the sunbed	30
Maintenance schedule	69, 70, 78	Safety information, maintenance	79	UV high-pressure lamps	
Overview	66	Scheduled cleaning	67	Canopy	91
Safety information	79	Scheduled maintenance	69, 70, 78	Side section	91
Make-up	22	Selecting an audio system	55	UV lamps, maintenance schedule	75, 76
Medication	22	Shoulder tanner, switching on and off	36	UV low-pressure lamps	
MP3 music, product information	19	Showering	22	Canopy	86
O		Side section		Facial tanner	96
Operating controls	27	Replacing high-pressure lamps	91	Side section	84
Operation at a glance	26	Replacing UV lamps	84	Sunbed base	82
Operator commitments	11	Skin sensitivity	22	V	
P		Skin types	4	Voice Guide	53
Packaging	20	Spare parts	20	Voltage	62
Plastic surfaces	21	Starting tanning	30	Volume	56
Power consumption	62	Sunbed base, replacing UV lamps	82		
Power, switching off	65	Sunbed, how to use it	30		

Warranty

JK-Products, Inc. – Limited Warranty

JK-Products, Inc. warrants its products to be free from defects in materials and workmanship under intended normal use as described in the unit's Operation and Instruction Manual, for a period of three (3) years from date of sale.

This Limited Warranty applies only to the original purchaser of the equipment through JK-Products, Inc. or its authorized dealer or distributor, and is not transferable.

Global Service USA obligations under this warranty are limited to repair or replacement of any defective part without charge for that part to the original purchaser, with the following exceptions:

- A Fluorescent lamps are warranted against defects for a period of thirty (30) days from date of sale.
- B Only parts obtained through JK-Products, Inc., its authorized dealers or distributors may be used. Transportation costs for parts shipped to the consumer and the return of defective parts to Global Service USA are not included.
- C Labor will be furnished without charge for ninety (90) days from date of purchase only. All labor and related charges must be authorized by Global Service USA prior to start of repairs, and must coincide with Global Service USA established rates and time allotment policy.
- D Acrylic: Refer to Manufacturer's Acrylic Warranty Policy.

It is imperative that the original customer completes and returns the enclosed warranty card within 10 days after purchase to insure valid registration and coverage for potential claims.

If the warranty card is not registered, proof of purchase from JK-Products, Inc. or its authorized dealer or distributor will be required prior to any consideration on warranty claims. This could result in service delays.

This warranty is extended to the individual or legal entity, whose name appears on the warranty registration card filed with Global Service USA, or whose name appears on the original sale document and may not be transferred to any other individual or legal entity.

This warranty does not apply to any failure of the product, or any parts of the product due to alterations, modifications, misuse, abuse, accident, improper maintenance, improper installation, acts of God or if the serial number on the product has been removed, altered or defaced. Adequate packaging must be used for returned goods to prevent freight damage.

There are no warranties which extend beyond the description on the face hereof. There is no express or implied warranty of fitness or merchantability.

The remedies provided in this limited warranty are the exclusive remedies provided to the purchaser by Global Service USA and are provided in substitution of all other remedies. Consequential and incidental damages are excluded.

No person, firm or corporation is authorized to obligate JK-Products, Inc. for any liability in connection with the sale or use of these goods.

Warranty

Limited Acrylic Warranty

JK Products, Inc. warrants its acrylic sheets to be free from defects in material and workmanship, under intended normal use, for a period of one (1) year from date of sale of the tanning bed. Due to the tanning lotions, cosmetics, disinfectant and improper cleaners used on tanning surfaces that cannot be controlled by JK Products, Inc., after the first thirty (30) days of warranty period acrylic will be subject to a prorated cost to the consumer.

JK Products, Inc. obligations do not include transportation charges on replacement acrylic.

JK Products, Inc. assumes no liability for the cost of removing defective sheets or installing replacement sheets, nor for damage to persons or property.

To make a claim, contact an authorized dealer or distributor of JK-Products, Inc. or Global Service USA with the model number, the serial number, and the date of purchase of the bed in which the acrylic will be used.

There are no warranties which extend beyond the description on the face hereof. There is no express or implied warranty of fitness or merchantability.

The remedies provided in this limited warranty are the exclusive remedies provided to the purchaser by Global Service USA and are provided in substitution of all other remedies. Consequential and incidental damages are excluded.

Global Service USA

A Div of JK Products & Services, Inc.
#1 Walter Kratz Drive
Jonesboro, AR 72401

☎ 800-445-0624

☎ 870-935-9046

e-mail: support@jkamerica.com

<http://support.jkamerica.com>

Warranty

Warranty Claims

Policy & Procedures

1. When to file a Warranty Claim:

In the event that your tanning system is not functioning properly under intended normal use as described in the unit's Operation an Instruction Manual, you may then have established cause to file a Warranty Claim.

**NOTE:**

Both the tanning system and legal registered owner must meet the criteria established under JK Products, Inc. Limited Warranty as described in this manual before any Warranty Claim will be considered.

2. Where to call to place a Warranty Claim:

JK-Products, Inc. is supported nationwide by an extensive dealer/distributor network through whom the majority of our units are sold. These dealers/distributors are required by contract to stock sufficient parts to meet the various warranty and nonwarranty needs of their customers.

Therefore, in order for you to properly file a Warranty Claim, you must locate the name and phone number of the dealer/distributor through whom you purchased your unit. Normally this information can be easily located either on your paid invoice or other proof of purchase documentation that you received when taking delivery of the unit.

Next, notify the dealer/distributor of the serial number, model number and date unit was purchased. This will initiate the Warranty Claim process.

Upon determination of the problem, your dealer/distributor can then supply you with the part(s) and proper instructions to return your unit to working order.

Each dealer/distributor has their own internal procedure for handling Warranty Claims and credits.

**NOTE:**

JK-Products, Inc., the manufacturer, does not involve itself in the direct handling of a Warranty Claim except where mitigating circumstances apply and where required by law.

**NOTE:**

If part returned to Global Service USA proves to be operational and not defective, or if product code numbers on part do not correspond with individual unit date on file with Global Service USA, then a 30% restocking fee will be charged in addition to the retail purchase price of part.

Acknowledgment of the Agreement is not required for acceptance of the foregoing stipulations.

Labor Warranty Claim/Credit Procedures

Global Service USA furnishes labor without charge for a period of 90 days from date of purchase. All labor and related charges must be authorized by Global Service USA prior to start or repairs, and must coincide with Global Service USA established rates and time allotment policy.

Please contact our Service Department for authorization and billing procedures.

Warranty

Limited Lifetime Warranty

Global Service USA warrants specific individual components of the tanning system against defects in materials and workmanship for the life of the product. Coverage is limited to units purchased after November 1, 1994.

This warranty is restricted by the following components only:

- Steel Back Panels
- Structural Steel Frame Components
- Exterior Steel Body.



NOTE:

Components are warranted on an individual basis and not as they may effect the complete product.

Warranty coverage does not include cosmetic abnormalities such as scratches, nicks, dents, rust, oxidation of paint or other cosmetic changes that do not interfere with the designed function of the unit.

This warranty does not include failure of the product due to alteration, modifications, misuse, abuse, improper maintenance, improper installation or repair.

This warranty is not transferable and is only applicable to the original purchaser named on a completed and registered warranty record at JK-Products, Inc. headquarters.

JK Products, Inc. obligations do not include transportation charged on the shipping of new components to the customer or on the return of de-

fective components of the manufacturer. All freight charges must be paid by the customer.

There are no warranties which extend beyond the description on the face hereof. There is no express or implied warranty of fitness or merchantability.

The remedies provided in this limited warranty are the exclusive remedies provided to the purchaser by Global Service USA and are provided in substitution of all other remedies. Consequential and incidental damages are excluded.



NOTE:

Any misuse, abuse, modification, alteration, improper maintenance, improper installation, etc. of this product or its intended use will subject said party to direct responsibility and liabilities for any and all consequences resulting from such action. Furthermore, such actions will void all warranties and may relieve Global Service USA of any liabilities relating to said product.



NO POSTAGE
NECESSARY
IF MAILED
IN THE
UNITED STATES

BUSINESS REPLY MAIL
FIRST-CLASS MAIL PERMIT NO 295 JONESBORO AR

POSTAGE WILL BE PAID BY THE ADDRESSEE

JK PRODUCTS & SERVICES, INC.
#1 WALTER KRATZ DRIVE
JONESBORO, AR 72401

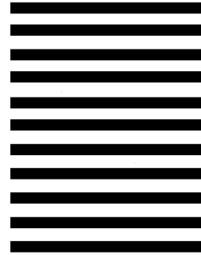

Separate here



SUN | **DASH**
PERFORMANCE | TANNING

soltron

Ergoline

Ⓐ WARRANTY REGISTRATION

Please complete the warranty section below. To validate and insure proper coverage, card must be completed and returned within ten (10) days of the date of purchase.

_____/_____/_____
Name of Purchaser Date of Purchase

Street Address or P. O. Box

City State Zip

()

Phone Number with area code

Company unit purchased from and amount paid.

Name of Business (if applicable)

E-mail

Circle Answers:

Type of Business:

Tanning Salon Video Store Health Club Beauty Salon

Other _____

Number of tanning beds at this location:

1-3 4-7 8-15 16-25 >25

If you experience any difficulties obtaining replacement parts from your distributor, please call Sun Ergoline at 800-643-0086, choose option 5.

Year & Model #

Serial #

Troubleshooting

In the case of a fault, a fault code¹⁾ appears on the display to simplify localizing of the fault cause:

- If a fault occurs, the fault code flashes in the display.
- If several faults occur, the fault messages are displayed alternately.
- The fault remedy is acknowledged by pressing the  button.

If the fault cannot be eliminated, contact Customer Service:



Global Service USA

A Div of JK Products & Services, Inc.
#1 Walter Kratz Drive
Jonesboro, AR 72401

 (800) 445-0624

 (870) 935-9046

e-mail: support@jkamerica.com

<http://support.jkamerica.com>

1) see separate instructions "Error codes", Order no. 800 751

SUN ERGOLINE, A DIVISION OF JK-PRODUCTS & SERVICES, INC.

1 Walter Kratz Drive · Jonesboro, AR 72401

Phone: 800.643.0086 (Toll-free) · Email: ergoline@sunergoline.com

Fax: 870.935.3618 · Website: www.sunergoline.com

Ergoline

1002509