

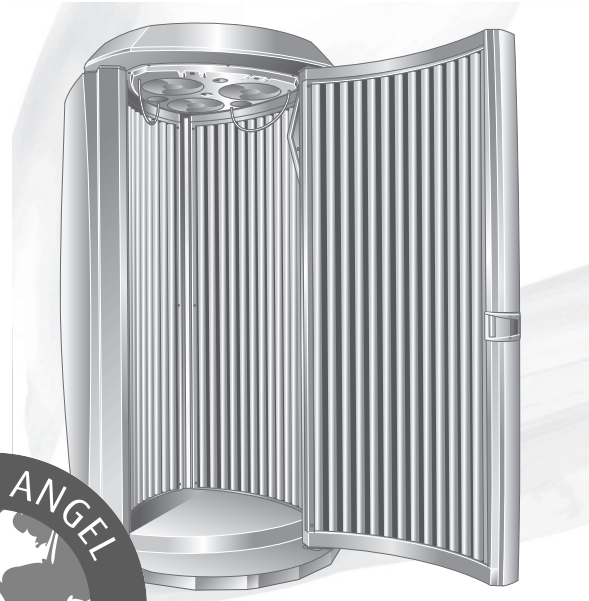

BEAUTY ANGEL

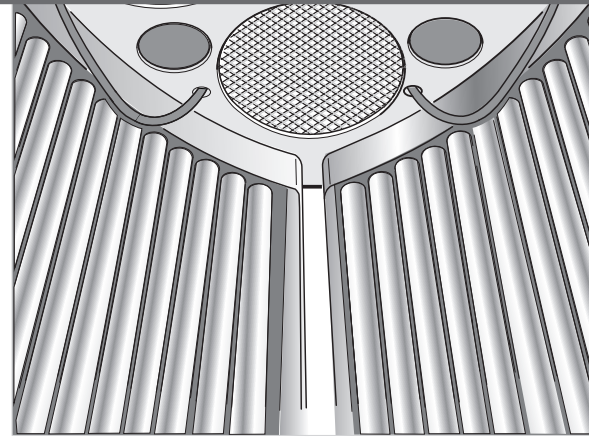

■ OPERATING INSTRUCTIONS



WARNING!

This device is designed for use with NON-UV emitting lamps only!

Use of UV lamps, or any lamps other than those specified for use in this device, may cause serious injury and is considered a violation of FDA regulations including:

Code of Federal Regulations Title 21 CFR1040
TITLE 21--FOOD AND DRUGS
CHAPTER I--FOOD AND DRUG ADMINISTRATION
DEPARTMENT OF HEALTH AND HUMAN SERVICES
SUBCHAPTER J--RADIOLOGICAL HEALTH PART 1040
PERFORMANCE STANDARDS FOR LIGHT-EMITTING PRODUCTS

Violation of this code may subject the violator(s) to litigation, fines, and possible imprisonment, etc.

Furthermore, adulterating this device in any way (including relabeling or using UV lamps etc.) will void the ETL listing of the device. Such action will cause the device to be considered out of compliance with federal, state, and local regulations.

If you have any questions regarding lamp replacement procedures, proper use, etc please contact the manufacturer directly at 1-800-643-0086.

Contact Information

Manufacturer: JK-Products and Services

1 Walter Kratz Drive
Jonesboro, AR 72401
USA
Tel.: 800.643.0086
Fax: 870.935.3618

Customer service / Technical service (Spare part orders for components):

JK-Global Service
1 Walter Kratz Drive
Jonesboro, AR 72401
USA
Tel.: 800.445.0624
Fax: 870.935.0946
E-mail: supportj@jkamerica.com
Web: <http://support.jkamerica.com>

Lamps and consumable parts:

JK-Light
1 Walter Kratz Drive
Jonesboro, AR 72401
USA
Tel.: 877.786.5267
Fax: 870.268.1202
Web: <http://www.jk-light.com>

DANGER!



Failure to observe these instructions:

- can result in serious injury and death,
- can result in damage to the device and the environment.

Read these instructions carefully before putting this device into operation.

Please observe the instructions and the code of conduct required to operate the device safely.

Please make the instructions and additional information from the manufacturer available to the personnel at their workplace.

Copyright

The copyright remains with JK-Holding GmbH.

The contents may not be partially or completely duplicated, distributed or utilized for competition purposes without authorization or disclosed to other parties.

The right to make technical changes in regard to the figures and information contained in this instruction manual is reserved!

Table of contents

Contact Information	2
Table of contents	3
1 General	5
1.1 Product Claims, Expectations, and Usage	5
1.2 Definitions	5
1.3 Symbol explanation.....	7
2 Information for the operator	8
2.1 Intended use	8
2.2 Foreseeable misuse.....	8
2.3 Operator's obligations	9
2.4 Personnel training	9
2.5 Scope of delivery.....	9
2.6 Transport, assembly and setup.....	9
2.6.1 Assembly	10
2.6.2 Ventilation	10
2.6.3 Setup location	11
2.7 Installation and Setup.....	11
2.8 Operation and maintenance.....	11
2.9 Decommissioning.....	12
2.10 Storage	12
2.10.1 Environmental regulations – disposal of lamps and batteries	12
2.11 Export.....	12
2.12 MP3 music (optional)	13
2.13 Instruction signs on the device.....	13
2.14 Technical modifications.....	13
2.15 Manufacturer's Warranty	14
2.16 Warranty and liability exclusions	14
3 Description	15
3.1 Scope of delivery.....	15
3.1.1 Optional.....	15
3.2 Equipment.....	15
3.3 Device description.....	16
3.4 Accessories (optional).....	17
3.5 Function description	17
3.7 VibraShape.....	18
3.8 Description: vibration programs	18
4 Operation	19
4.1 Safety information for the user	19

4.1.1	*****Red Light Therapy.....	19
4.1.2	VibraShape (Vibration plate)	20
4.2	Application times	22
4.3	Application tips	22
4.4	Operating overview	24
4.4.1	Navigation	25
4.5	Functions.....	26
4.6	Start.....	27
4.7	Connect MP3 player.....	28
5	Cleaning and maintenance	29
5.1	Safety information for cleaning and maintenance	29
5.2	Faults.....	30
5.3	Cleaning	30
5.3.1	Disinfection.....	30
5.3.2	Cleaning the surfaces.....	31
5.3.3	Lamps.....	31
5.4	Cleaning plan	32
5.5	Maintenance.....	33
5.5.1	Acrylic glass panel.....	33
5.6	Maintenance plan	34
5.7	Instructions for replacing the lamps.....	35
5.7.1	*****Red Light Therapy lamps.....	35
5.7.2	Starter.....	36
5.8	Clean or replace lamps in the door.....	36
5.9	Clean or replace lamps on the side panels	38
5.10	Clean or replace Ambient Light	40
6	Technical data	41
6.1	Power rating, electrical specifications and noise level.....	41
6.2	Dimensions.....	42
6.3	Lamp sets.....	43
6.3.1	BEAUTY ANGEL CVT 30	43
6.3.2	Accent lighting	44
6.4	Spare parts and accessories	44
7	Appendix	45
7.1	Signs and stickers on the device	46
8	Index	50

1 General

1.1 Product Claims, Expectations, and Usage

Exposing the skin to specific light waves within the 580 to 700 nanometer range enhances the overall appearance of a person's skin and skin tone.

Moderate exposure to such light waves over an extended period -- and in conjunction with adequate skin hydration via the consumption of water, the application of vitamin enriched skin creams, proper diet and exercise also helps contribute to this process.

This in turn leads to a temporary reduction in the appearance of fine lines and wrinkles. The short-term effect is firmer skin and a more balanced, even skin tone.

A recommended treatment consists of 2 to 3, 12-minute sessions per week over a period of approximately 90 days. Additional applications over a longer period of time are recommended for more mature users.

Following the treatment, weekly sessions are sufficient to maintain the effects. The performance is supported by the use of skin care products, proper hydration, diet and exercise.

*These statements have not been evaluated by the FDA (Food & Drug Administration). This product is not intended to treat, cure, prevent, or diagnose any disease or illness. The information provided is not a substitute for advice from a licensed physician or other healthcare professional. Actual results will vary according to skin type, usage, genetic influences, diet, exercise, lifestyle, etc. There is no guarantee of results.

THIS DEVICE EMITS NO UV-LIGHT!

However, prior to use, please use caution and evaluate any medications, creams, etc that may produce a photosensitive reaction.

1.2 Definitions

Operator

People who provide devices to users on a commercial basis. The operator is responsible for the orderly operation of the device as well as the compliance with the maintenance intervals.

User

A person who uses the device at a commercial location.

Personnel

People who are responsible for the operation, cleaning as well as general maintenance work and who instruct the users in the operation of the devices.

Electrician

A person with suitable professional training, knowledge and experience which enables them to identify and avoid the dangers which can arise from working with electricity.

Authorized, trained and qualified personnel

Qualified staff from an external company who have been trained and authorized by the manufacturer for assembly and maintenance work with specific devices.

1.3 Symbol explanation

The following types of safety notices are employed in these operating instructions:

DANGER!



Type and source of hazard

This safety notice indicates the existence of a direct danger to body and life.

DANGER!



Type and source of hazard

This safety notice warns of dangers to body and life which are caused by electricity.

WARNING!



Type and source of hazard

This safety notice warns of machine, material or environmental damage.



NOTE:

This symbol does not identify any safety notices, but provides additional information to better understand the processes.

2 Information for the operator

2.1 Intended use

BEAUTY ANGEL

This device serves to provide cosmetic stimulation of the skin by means of red light (photo-bio-stimulation). Further information for this can be found on pages 17 and 20.

Some people are not permitted to use the device, see page 20.

The device may not be used by people with reduced physical, sensory or mental capabilities or who have insufficient experience and/or knowledge without supervision. A person responsible for their safety must ensure, either by supervision or instruction, that the device is used correctly and safely. If there is any doubt, use of the device by such categories of persons is forbidden!

This device is only to be operated with the specified lamps or their equivalent. The usage times given in these operating instructions are valid only for the specified lamp set.

Any other use shall be considered improper. The manufacturer cannot be held liable for damage or injuries resulting from this. The operator bears the sole risk for this.

Proper use also includes compliance with the manufacturer's instructions and its operating and maintenance conditions. The device may only be operated, maintained and repaired by persons familiar with these tasks and who have been informed of the dangers involved.

VibraShape Function

The vibration plate may also be used during the light application. The vibration plate is used for muscle stimulation of healthy people. If required, the vibration plate can also be operated independently of the lamps.

The vibration plate is not intended for medical applications!

The vibration plate should not be used by pregnant persons or by people with diseases and limited medical conditions. A list of the conditions that prevent use of the vibration plate can be viewed on page 21.

2.2 Foreseeable misuse

The following uses of the device are explicitly prohibited:

- Multiple people may not use the device at the same time.
Persons with light sensitivity or inappropriate eyewear may not use the device.
- People with a body weight of more than 300 lbs may not use the device.
- Extending the specified application times can place excessive demands on the skin due to the emitted light. A minimum period of 24 hours should lapse between each 12 minute treatment.
- No other persons are permitted in the vicinity of the cabin when using the device, this especially applies to children.
- ONLY NON-UV Red Light Therapy lamps may be used in this device!

2.3 Operator's obligations

As the operator you are responsible for providing clear operating, cleaning and maintenance instructions. You are also responsible for ensuring the intended use and the proper operation of the device by means of training and instruction for the personnel and provision of all appropriate safety devices (including eyewear).

Your operating instructions must enable the safe use and safe operation of the device and take into account the characteristics and expertise of your company and also the national work safety and environmental protection regulations.

2.4 Personnel training

As the operator you are obliged to train your personnel and instruct them in the established legal and accident prevention regulations. Ensure that your personnel have understood and observe these operating instructions. This applies in particular to the:

- information in 'Intended use' and 'Foreseeable misuse'
- safety instructions in the 'Operation' chapter
- operating instructions
- cleaning and maintenance instructions

Please make the instructions and additional information from the manufacturer are available to personnel.

Regularly check your personnel's safety consciousness and awareness of the risks, taking into account your operating instructions.

Please ensure that the cleaning intervals are complied with, in particular cleaning after every application.

Please ensure that your staff provide your customers with appropriate advice, in particular regarding application times, possible risks and the operation of the device.

2.5 Scope of delivery

Information regarding the scope of delivery is contained in the 'Description' chapter on page 15.

2.6 Transport, assembly and setup

The device is delivered and installed by trained representatives of JK Products & Services or its distributor. Only persons who have been trained and are authorized to perform these functions may work with the equipment.

As an operator you are responsible for complying with the on-site ventilation and electrical requirements at the setup location, see page 10.

2.6.1 Assembly

DANGER!



Personal danger due to electric shock or burns!

- The assembly and electrical connection must comply with local and national regulations.
- The electrical installation must have an easily accessible disconnect or breaker that complying with overvoltage category III.
- Assembly, installation, upgrading or repair of the device may only be carried out by specially trained and instructed personnel.

Information regarding the disassembly and assembly of the device is available in the separate assembly instructions. These assembly instructions are intended solely for use by the manufacturer's service personnel or by qualified specialists authorized by the manufacturer.

2.6.2 Ventilation

WARNING!



Risk of overheating due to air flow problems!

Operating faults possible.

- Do not change, obstruct or block the air inflow and outflow to the device or make any unauthorized changes to the device. The manufacturer shall bear no liability for damage or injuries resulting from such actions.
- Observe the ventilation system data.
- Do not set up and operate the device on the transport pallet!

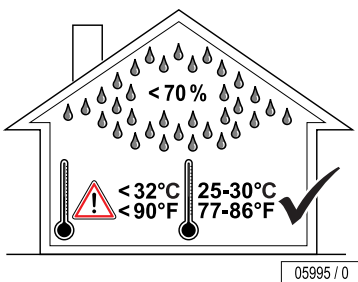

Data regarding the air supply and ventilation planning is available in the planning manual (<http://support.jkamerica.com>). You can also obtain this data from your distributor or the customer service department (see page 2).

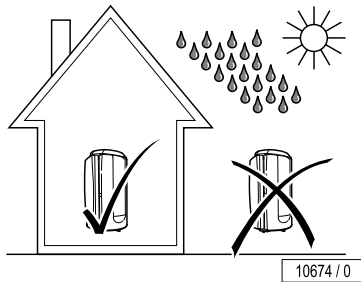

2.6.3 Setup location

The device may not be operated outside.

Please contact the customer service department (see page 2) for assistance before putting the device into operation.

2.7 Installation and Setup

The initial installation and setup is performed by the manufacturer's own service personnel or by an authorized dealer/distributor. The device is only released to the owner when installation is complete and the system is ready for use.

If the device has not been used for a long period of time then it must first be inspected by our customer service department or by another authorized company before being put back into operation again.

The device is operated with an external timer.

A timer must be attached so that the device automatically switches off by reaching <110 % of the selected running time even if the controller fails. This device's running time is has a double protection in the form of primary and secondary backup systems to prevent operation of the system beyond that prescribed time.

Dependent on the local utilities company, the devices can transmit interference to the power system of the building that impair the audio-frequency remote control system used by the utility company. This can, for example, interfere with the function of night-storage heaters.

If faults occur due to the operation of the devices, then the operator is responsible for the installation of an audio frequency blocking device in the building electrical installation. Please contact your electrician. The electrician is familiar with the technical connection conditions of your local utility company so that the audio-frequency blocking device can be matched to the power system of your utility company.

2.8 Operation and maintenance

Error-free operation, maintenance and service are required in order to ensure that the health and safety of the users is not endangered during operation and to ensure that the device is in a fault-free operating condition.

Please observe the information and recommendations provided in these operating instructions. Please ensure that the intervals for the inspection, maintenance and service are complied with. Please ensure that the lamps are replaced after the specified usage time.

Unauthorized modifications and changes to the device and its control unit are prohibited. Failure to comply with this voids the warranty! Operation of this system beyond the scope outlined by JK Products & Services relieves JK from any liabilities resulting from the unapproved operation.

2.9 Service and Decommissioning

The device must be disconnected from the power supply in order to temporarily or permanently remove the system from service.

The legal requirements regarding disposal must be observed when permanently decommissioning the device.

2.10 Storage

Store the devices in a dry, frost-free location with a stable temperature. Once the device has cooled off, pack it in plastic wrapping to protect it against scratches.

2.10.1 Environmental regulations – disposal of lamps and batteries

Red Light Therapy lamps contain fluorescent materials and other waste products containing mercury. Batteries contain heavy metal compounds. Some areas of the USA and Canada have specific regulations regarding disposal of these waste. Please check the laws in your area and act in accordance with municipal waste regulations. Please retain proof of proper disposal of lamps and batteries.

Your local regulatory agency can assist you with the disposal of lamps and batteries.

- Report the number of lamps and batteries to your local agency by telephone or in writing.

The regulatory agency can provide you with a delivery point for your lamps or will take care, in conjunction with a disposal company, of the collection and proper disposal of the lamps (Fees for this may apply). Please contact your code enforcement officials for more information regarding laws governing disposal of these components in your area.

2.11 Export

This device is intended for the USA and Canadian markets only and must not be exported to or operated outside the USA or Canada! The manufacturer does not accept any liability in case of non-observance! It is emphatically emphasized that non-compliance with this instruction may result in high liability risks for the exporter and/or the operator.

2.12 MP3 music (optional)

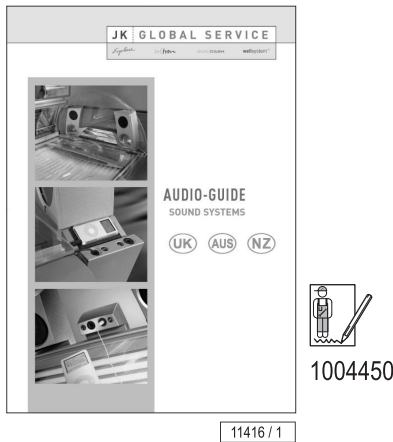

If an MP3 player is used privately during the application, then this does not constitute a public performance in the sense of copyright law, so that no reporting or fee obligation exists on the part of the studio operator towards the organisation responsible for issuing the commercial performance rights.

For the public use of MP3 music files, the same legislation applies as for all other music sources: As a studio operator/studio owner, you may only play original Audio-CDs, MCs, audio-DVDs etc., on your premises and/or play music via the 'MP3-music modules' which are provided in the professional devices, if you have acquired the necessary stage rights. You can acquire these from the organization responsible for issuing commercial performance rights in your country (for more information please contact the RIAA). Copy-protected audio-CDs, MCs, audio-DVDs etc., as well as titles contained on these media, may not be converted to MP3 format and/or saved on HDD, audio-CDs, MCs, audio-DVDs etc., if software is used to do this, which disables or circumvents the copy-protection contained on the media.

You must be ready at any time to prove your granting of stage rights by presentation of the appropriate stage rights certificate when requested by a representative or another controlling body of the responsible organisation.

As long as you observe all the listed instructions and have acquired the necessary rights for use of the 'MP3-music-module', you may convert your original audio-CDs, MCs, audio-DVDs etc. into the MP3 format required by the player. Only one copy (duplicate or MP3 format conversion) of lawfully acquired audio-CDs, MCs, audio-DVDs etc. may be made. The source media (original media) must be retained and may not be used simultaneously.

Further details can be found in the information brochure 'Audio Guide' available in German and English on the Internet at www.jk-global-service.de.

2.13 Instruction signs on the device

See Appendix page 47.

2.14 Technical modifications

The device has been constructed in accordance with the current state-of-the-art technology and the applicable safety regulations. The illustrations and specifications on these instructions are subject to technical modifications which are required in order to improve the device.

Unauthorized modifications and changes to the device and its control unit are prohibited. Failure to comply voids the warranty and ETL/Intertek seal! Use only original spare parts. Failure to comply voids the and ETL/Intertek seal!

2.15 Manufacturer's Warranty

On behalf of customers who have purchased an Red Light Therapy device for private or commercial use from one of our sales partners, JK Products accepts liability for any defects that arise in accordance with the following regulations; consumable parts such as lamps and starters as well as the acrylic panel are not covered by the warranty.

The guarantee stipulates that JK Products will rectify any defects within a time period predetermined by the repair or exchange of the defective part.

Claims made in accordance with this warranty may be filed with JK Products or the sales partner from whom the product was purchased on presentation of the warranty card; this warranty is valid for a period of 36 months for parts/ 90 days for labor from the date of purchase.

This does not affect the rights of the customer under the existing warranty with regard to any claims that the customer might have in accordance with the contract of purchase.

2.16 Warranty and liability exclusions

Warranty and liability claims for personal injury and property damage are excluded if they are the result of one or more of the following causes:

- improper use of the device;
- improper assembly, commissioning, operation and maintenance of the device;
- operating the device with faulty safety equipment or improperly attached or non-functional safety and protective equipment incl. warning signs;
- not complying with the information in the operating instructions regarding transport, storage, assembly, commissioning, operation and maintenance;
- the use of untrained personnel;
- unauthorized changes to the device or the control unit;
- inadequate monitoring of parts subject to wear;
- repairs carried out improperly;
- the use of non-original spare parts;
- emergencies and disasters resulting from the influence of foreign materials or „acts of God“.

3 Description

3.1 Scope of delivery

- Red Light Therapy device
- Technical documentation (Printed documentation and Operation Instructions CD)
- Red Light Therapy lamps
- Ambient light (Effect lighting)
- VibraShape
- Allen key
- Connecting lead

3.1.1 Optional

See Page 17.

- 3D sound

3.2 Equipment

Device equipment varies depending on the model.

In this description, all standard and optional components/functions are taken into account which must be observed during operation and/or when performing maintenance.

The control panel also differs according to the varying equipment: Only those buttons are visible that can be operated, i.e. the corresponding function must be included in the device's equipment.

3.3 Device description

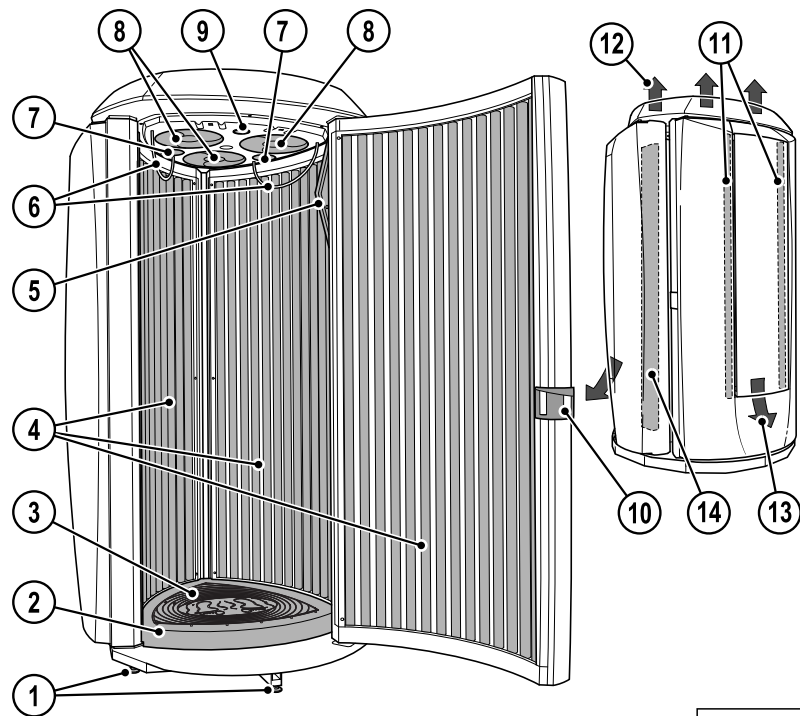

10592 / 1

1. Adjustable feet
2. Base plate
3. Foot mat (silicone) and vibration plate (VibraShape)
4. Red Light Therapy lamps
5. Control panel, headphone connection
6. Handles
7. Loudspeaker (optional)
8. Fans (body cooling)
9. Interior lighting (LED)
10. Door handle
11. Accent lighting
12. Exhaust air (body cooling)
13. Exhaust air (equipment cooling)
14. Cable duct and ambient light (accent lighting)

3.4 Accessories (optional)

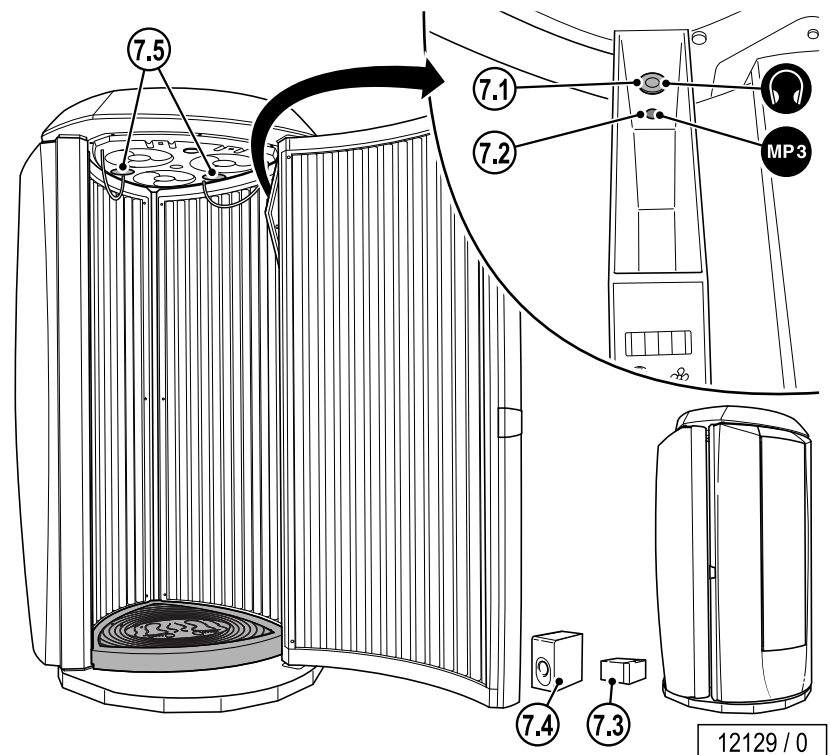

Stereo sound

7.5 2 Loudspeakers

3D sound

7 Audio system with Voice Guide

7.1 Headphone connection

7.2 MP3-connection

7.3 Sound Box

7.4 Subwoofer

7.5 Loudspeakers

MP3 cable (not pictured)

3.5 Function description

The application with red light (photo-bio-stimulation) promotes the formation of collagen and elastin.

The short-term effect shows itself as a firmer and closer skin feeling and a more vital facial coloration. This is the result of oxygen enrichment and an increased level of ATP (adenosine triphosphate, the molecule for energy transfer in the metabolic system). During the application process the serotonin level also increases which results in a feeling of wellness and relaxation.

Over the middle and long-term the skin complexion improves as a result of greater moisture and oxygen levels. Natural signs of aging are mitigated, the skin's collagen and elastin network strengthened and revitalized.

A complete treatment consists of at least 8 - 12 applications over a period of approximately 4 weeks. A higher number of applications over a longer period of time is recommended for more mature users.

Following the treatment 1 - 2 applications per month are sufficient to maintain the effect. The effect is supported by the use of anti-ageing skin care products.

3.7 VibraShape





The BEAUTY ANGEL not only offers an innovative light treatment but also a healthy training effect. This is made possible by a vibration plate integrated into the standing surface which activates the entire musculature through its vibration. The patented seesaw function of the training plate simulates human walking which, in contrast to other training devices, makes the Whole Body Vibration into a 100 % physiological training method. As a result, all of the muscles of the legs up to and including the torso, abdomen and back are trained. The upper body and head can remain still.

As such, the Whole Body Vibration supports muscular development, stimulates fat loss and improves mobility and physical coordination. The improved microcirculation of the blood stimulates the metabolism and an improved feeling of general wellness. The musculature is trained, connective tissues become firmer and the complexion improves. Regardless of whether young or old: With the four customized Whole Body Vibration programs you rapidly achieve your desired goal. You can achieve optimal results with a treatment duration of 12 minutes.

The vibration programs all run for 12 minutes but can also be customized on an individual basis depending on the intensity of the program or switched off completely.

Users can combine the red light treatment and the vibration program with each other as desired or use them completely separately as individual applications.

3.8 Description: vibration programs

Program ¹⁾		Procedure	Frequency
Pr 1		Loosening and relaxing the muscles	Low oscillating frequency
Pr 2		Fitness program for newcomers	Medium oscillating frequency
Pr 3		Fitness program for advanced customers	High oscillating frequency
Pr 4		Improving the skin texture and guarding against cellulites	Alternating oscillating frequency

¹⁾ Each program starts with a warm-up phase and ends with a cooling-down phase.

4 Operation

4.1 Safety information for the user

DANGER!



Danger of hearing damage!

Using earphones or headphones at high volume can result in permanent hearing damage.

- Do not set the volume too high.

4.1.1 Red Light Therapy device



NOTE:

Extending the specified application times can place excessive demands on the skin by the emitted light. A period of no less than 24 hours must be observed between each 12 minute treatment.

The following people are not allowed to use the equipment:

- Pregnant women
 - People younger than 18 should have parental permission.
 - People with epilepsy
 - People with illnesses which cause light sensitivity or are aggravated by light.
 - Although this device emits no UV, persons who take medication or herbal remedies which cause light sensitivity (e.g. antibiotics, anti-inflammatory agents, antifungal agents or St. Johns wort).
- **Seek medical advice before use if in doubt!**

A light treatment is not recommended in the following circumstances:

- If you have utilized an oxygen facial pack in the last 24 hours,
- If your facial skin has been electronically tightened in the last 24 hours
- If your skin has been chemically treated within 24 hours
- If you have received a facial injection in the last 24 hours.
- If your skin has been burned (by UV, by chemicals, or by heat).

Behavior before, during and after a light application:

- No other persons are permitted in the vicinity of the cabin when using the device, this especially applies to children.
- Remove all jewelry (including piercings) prior to the application.
- Remove cosmetics before using the device
- A light application is not damaging to the eyes. We do recommend wearing eye protection during the application for safety and comfort against the bright light.
- Always comply with the recommended application times.

4.1.2 VibraShape (Vibration plate)

Side effects

DANGER!**Risks of damage to health!**

Vibrations can cause or aggravate health problems.

The following people are not allowed to use the equipment:

- Pregnant women
- People with DVT (Deep Vein Thrombosis)
- People with fresh wounds following an operation or surgery
- People with epilepsy
- People with acute illnesses / inflammations
- People with pacemakers
- People suffering from retinal detachment
- People with acute osteoporosis

People with the following illnesses may only use the device after consultation with their doctor:

- Cardiovascular diseases
- Hip and knee implants
- Severe diabetes
- Severe migraine attacks
- Tumors
- Gallstones or kidney stones
- Acute thrombosis
- Acute inflammation of the muscular-skeletal system
- New fractures to well-trained limbs
- New infections
- Acute hernia / inter-vertebral disc diseases / scoliosis
- Rheumatoid arthritis
- Arthritic or orthopedic conditions (joint diseases)

People with recently implanted intrauterine devices (contraceptive coils), metal pins, screws or plates are also only to use the device after consultation with their doctor.

Side effects

The use of the vibration plate may lead to the following side effects:

- Itching in regions of the body being trained
- Nausea and vertigo
- Rapid and brief drop in blood pressure
- Rapid hyperglycemia in the event of diabetes

Diabetics should always have dextrose on hand! The side effects of nausea, vertigo, drop in blood pressure and skin irritations are generally harmless. Older users should be especially warned about the possibility of vertigo and a sudden drop in blood pressure. People who have skin injuries such as blisters or wounds on the soles of their feet are not allowed to use the vibration plate.

4.2 Application times

Applications per week	Moderate Schedule	Intensive Schedule
	[Number]	[Number]
1. Week	2	2
2. Week	2	2
3. Week	2	2
4. Week	2	2
5. Week	2	2
6. Week	2	2
7. Week	2	2
8. Week	2	2
9. Week	1	2
10. Week	1	2
11. Week		1
12. Week		1
After treatment:	1-2 x per month	

4.3 Application tips

Red Light Therapy device

- Stand up straight and in the center of the device during the application.

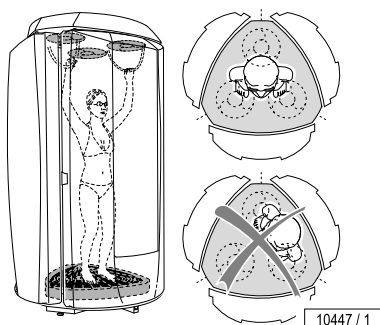

10447 / 1

VibraShape

DANGER!



Risk of injury!

The vibration function is not suitable for all users.

- Please observe the restrictions on page 21.



NOTE:

Each program starts with a warm-up phase and ends with a cooling-down phase. A vibration program normally lasts for 10 minutes. The vibration program will terminate with light application if an application time of less than 10 minutes has been entered. A one-minute long cooling down phase will start immediately (example: 7 minute application time, 7 minute vibration program + 1 minute cooling down phase).

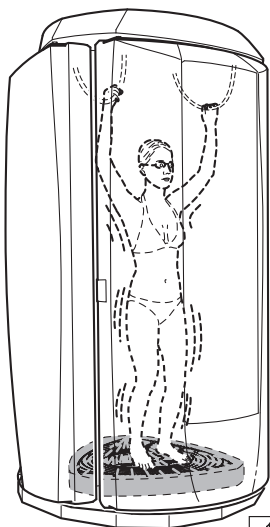
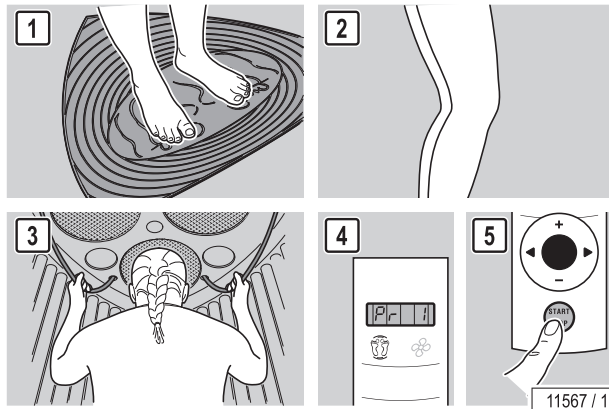

11566 / 1

- Place your feet on the footmarks (1).
- Bend knees slightly (2).
- If desired, you can hold onto the hand straps for safety(3).
- Select Program 1 as the first application to test your reaction to the vibration (4).
- Press the START/STOP button (5) to stop the vibration plate if it is causing discomfort or vertigo.

4.4 Operating overview

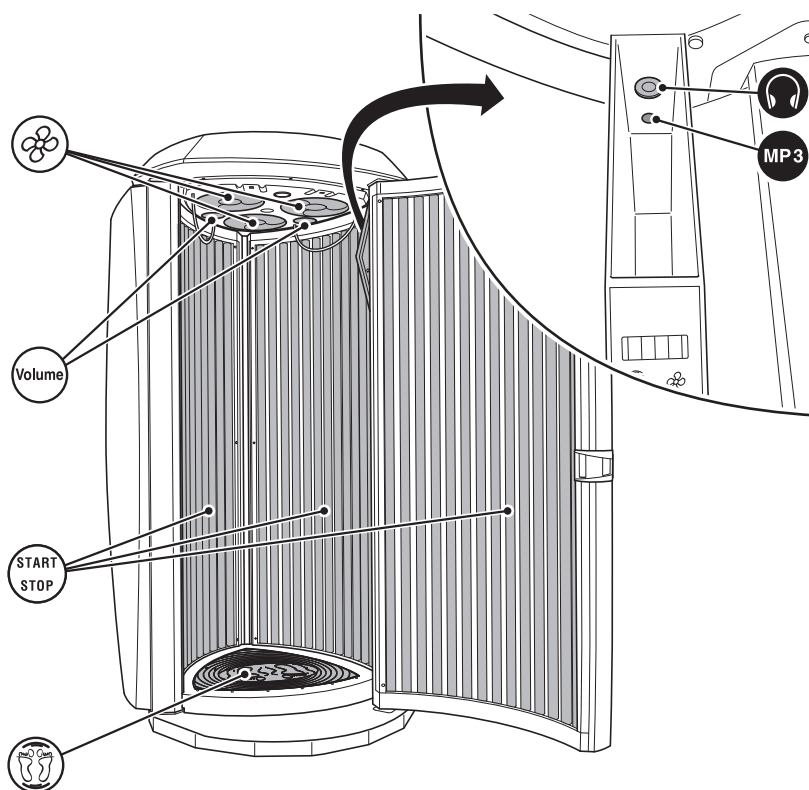

12130 / 0

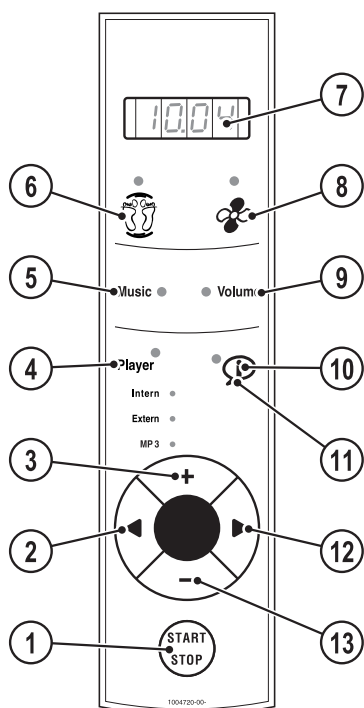

12131 / 0

1. START/STOP button
2. Left navigation arrow button
3. Plus button
4. Audio system icon (optional)
5. Music icon (optional)
6. VibraShape icon
7. Display – Functions ...
8. Body cooling icon
9. Volume icon (optional)
10. Voice Guide icon (optional)
11. INFO icon (optional)
12. Right navigation arrow button
13. Minus button

4.4.1 Navigation

The device is operated with the navigation ring.

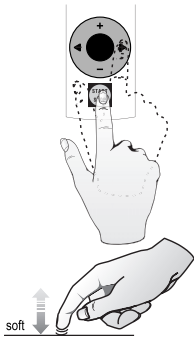

10958 / 0



Switch on lamps:

- Press the button once.

Switch off lamps/interrupt application:

- Hold the button.

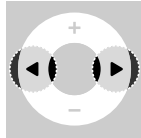

Select device function (go to pictogram)

MUSIC e.g. MUSIC

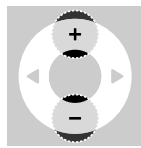



Select sub-function (if available)

Change setting

















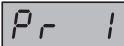
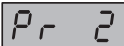
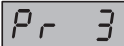
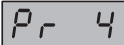

The LED indicator for the available functions and the navigation ring are illuminated in default mode after starting up the device. After selecting a function, the respective LED indicator and the navigation ring flash for a few seconds. Settings can be changed during this time.

Operation – Demonstration mode

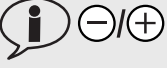
–  press until 

The audio functions and VibraShape can be tested in demonstration mode. You have 30 seconds in which to select the function.

4.5 Functions

Function	Button sequence	Description	Information
1. Lamps		START/STOP Switch lamps on/off during the application (in combination with VibraShape: see below).	If the lamps are switched off during the application, the application time continues to run.
2. VibraShape	     	Select VibraShape <ul style="list-style-type: none"> Press the button once: Vibration plate will be switched off Hold the button: Vibration plate and lamps will be switched off  Program 1  Program 2  Program 3  Program 4	START/STOP also switches off the lamps.
3. Body cooling		Body cooling control 	
4. Voice Guide	 	Switch VoiceGuide off:  Switch VoiceGuide on	Voice Guide provides an acoustic aid when running the unit and is only works in conjunction with 3D sound. Voice Guide is switched on by default when getting ready for operation and during application.
5. INFO	  	Switch INFO on:  Select INFO text Switch INFO off – hold the button	General information about the device.
6. Volume	 	Volume control Tone off – press button  until displayed 	

Function	Button sequence	Description	Information
7. Audio system	◀/▶ Player ⊖/⊕	Selecting the audio system (channel)	
	Player ⊖/⊕ Intern •	1-CH Internal: Music SD card	
	1-CH Intern • ▶/◀ Music ⊖/⊕	Select title rr.01 - rr.99	
	Player ⊖/⊕ Extern •	E-CH External: Externally connected systems, e.g. CD player	
	E-CH Extern • ▶/◀ Music ⊖/⊕	Select channel CH.01 - CH.16 (maximum)	Refer to 'Presettings' Guide on Operating Instructions CD.
	Player ⊖/⊕ MP3 •	-P3- MP3 player	
8. Accent lighting running time			Refer to 'Presettings' Guide on Operating Instructions CD.

4.6 Start

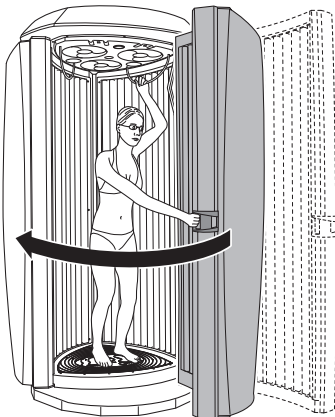

10591 / 2

- Close the door.
- Press the START/STOP button.

Upon starting the following functions are switched on:

- Lamps
- Body cooling
- Audio system (optional)

4.7 Connect MP3 player

DANGER!



Danger of hearing damage!

Using earphones or headphones at high volume can result in permanent hearing damage.

- Do not set the volume too high.

Users may connect their MP3 players to the red light therapy device if the audio system accessory is installed.

1. MP3 connection cable is provided by the studio operator (1.5 m / 2 x 3.5 mm stereo jack plug).
2. MP3 player: see the documentation from the manufacturer of the MP3 player.

Connect:

- Plug the MP3 cable (stereo jack plug) into the Audio system.
- Plug the MP3 cable into the MP3 player.
- Select the music title and start.

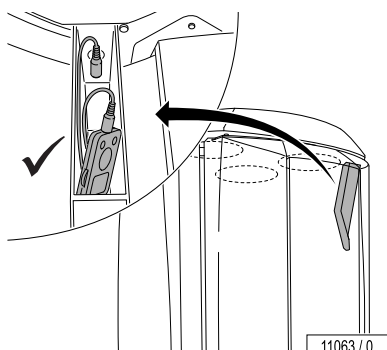
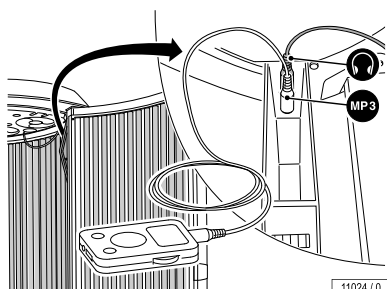
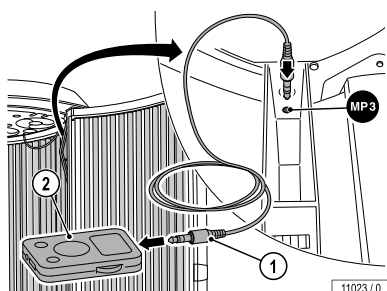

WARNING!

Heat damage to the MP3 player is possible

- Only place the MP3 player in the designated area.

Cable may break-off, cable jacks may be damaged!

- Do not pull on the cable when unplugging the MP3 player.

5 Cleaning and maintenance

5.1 Safety information for cleaning and maintenance

DANGER!



Electricity throughout entire device

Personnel danger due to electric shock or electric burns.

- Before beginning work disconnect all of the power connections from mains voltage.
- Secure all of the disconnected connections against accidental reactivation.
- Check that the device is disconnected from mains voltage.
- All of the work and electrical connections must comply with the national regulations of the country in which the device is being operated (e.g. the VDE regulations in Germany) and must be performed by appropriately trained specialists.

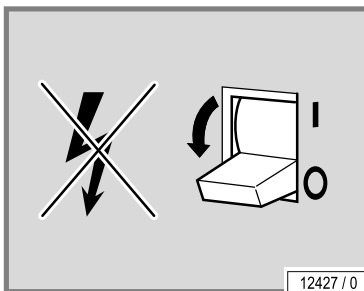

12427 / 0

If work is to be performed on the devices, they must be de-energized. That means that all live cables must be switched off.

Switching off the device alone is insufficient, as certain points may remain energized. Switch off fuses or breakers before performing any work and – if possible – remove them.

Accidental reactivation can result in serious accidents. Immediately after de-energizing, secure all switches or fuses used for de-energizing against being switched on again.

- Lock the fuse box with a padlock.

In case of circuit breakers which cannot be unscrewed, a strip of adhesive tape may be applied over the actuation lever with the wording 'Do not switch, danger!'.

A prohibition sign with the text:

'Work in progress!'

'Place:

'Sign may only be removed by:

must always be securely mounted immediately.

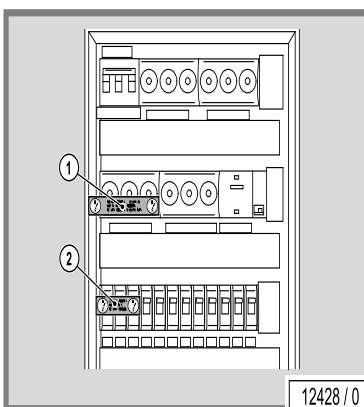

12428 / 0

5.2 Faults

Error codes are output to the display to simplify troubleshooting:

- If a fault occurs, the error code flashes on the display.
- If several errors occur, the error messages are displayed alternately.
- Error elimination is acknowledged by pressing the **START/STOP** button.
- If the error cannot be cleared, inform Customer Service - see page 2.

More detailed information regarding the error description and solutions is available in 'Error Codes'

5.3 Cleaning

DANGER!



Infections can be spread by skin contact!

All objects/device parts, which can come into contact with the user during the application, must be disinfected after every application:

- Handles and control panel
- Protective goggles
- MP3 cable
- Acrylic glass panels
- Foot mat (Silicone)

5.3.1 Disinfection

We recommend the following cleaning agents for rapid and thorough disinfection:

Antifect® fast disinfectant cleaner

Lucasol® concentrate, 250 ml Order-no.: ...

Spray bottle, 1 ltr. (empty) Order-no.: ...

Spray nozzle Order-no.: ...

Mixing container, 5 ltr. (empty) Order-no.: ...



NOTE:

For thorough disinfection, the application time must be adhered to. Follow the manufacturer's instructions for use.

5.3.2 Cleaning the surfaces

Acrylic glass panel

WARNING!



Do not rub with a dry cloth – danger of scratching!

Failure to comply voids any warranty claims.

- For fast, hygienic proper cleaning of acrylic glass surfaces, use specially developed fast disinfectant cleaner Lucasol®.
- Other cleaning agents, especially concentrated disinfectants or solvents (e.g. Lysoform, ethyl alcohol or other liquids containing alcohol) should never be used for cleaning.

Plastic surfaces

For cleaning the remaining painted and unpainted plastic surfaces, it is best to simply use warm water and a cloth. Never use aggressive cleaning agents containing alcohol or essential oils. These may lead to damages not covered by the warranty.

Prevent damage to the acrylic glass and plastic surfaces by removing rings, watches, bracelets etc. before starting cleaning work.



02756 / 0

5.3.3 Lamps

The lamps can be cleaned with a damp cloth and without additional cleaning agents where necessary.

5.4 Cleaning plan

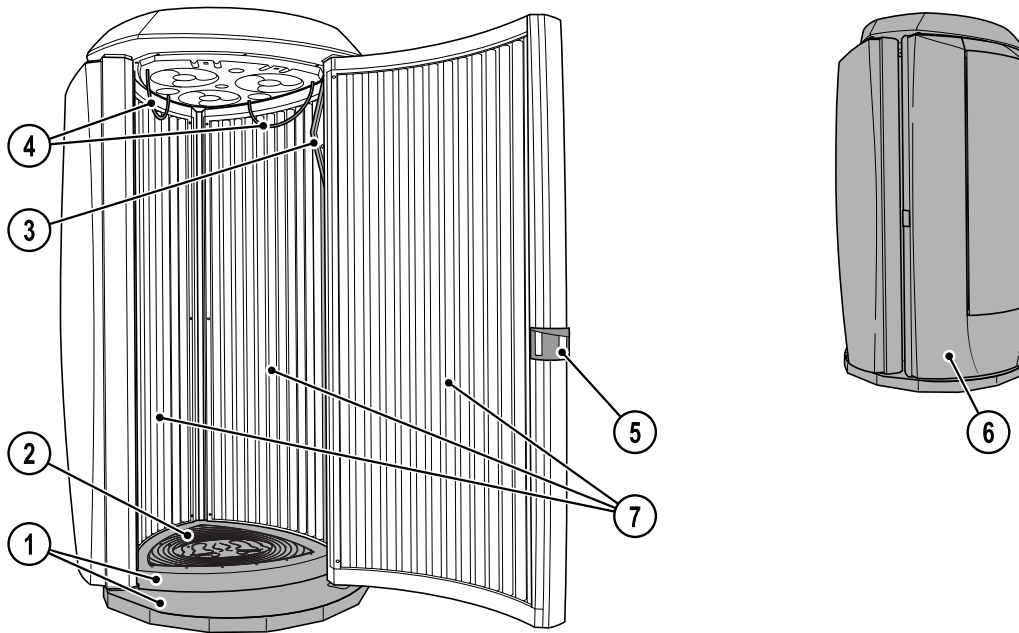

12149 / 0

Component	Interval	Activity	See page
	After each application	When necessary	
1 Entry area	X	Cleaning and disinfection	31
2 Foot mat (Silicone)	X	Cleaning and disinfection	31
3 Control panel	X	Cleaning and disinfection	31
4/5 Handle	X	Cleaning and disinfection	31
Protective goggles	X	Cleaning and disinfection	31
MP3 cable	X	Cleaning and disinfection	31
6 Surfaces		X Cleaning	32
7 Acrylic glass panels		X Cleaning	32



NOTE:

If desired, cleaning must be confirmed after each application by pressing the START/STOP button (when the warm-down time for the main fan has finished).

5.5 Maintenance

Maintenance and care play a major role in deciding whether the device meets the requirements placed on it. Compliance with the specified maintenance schedule and the regular maintenance are absolutely necessary.

The current operating hours of maintenance parts can viewed in service mode.

The device must be subjected to regular inspections by JK Products & Services representative or an approved dealer/distributor company every 12 months (from installation) to maintain its proper condition!

5.5.1 Acrylic glass panel

Over the course of time the acrylic glass panels become less translucent as a result of usage and must be replaced on regular basis.

5.6 Maintenance plan

WARNING!



Only use genuine **spare parts** of the same type! If other parts are used then the device no longer complies with the conformity declaration and may not be operated any longer! Any liability for damage or injury proven to be the result of the use of non-genuine spare parts is excluded.

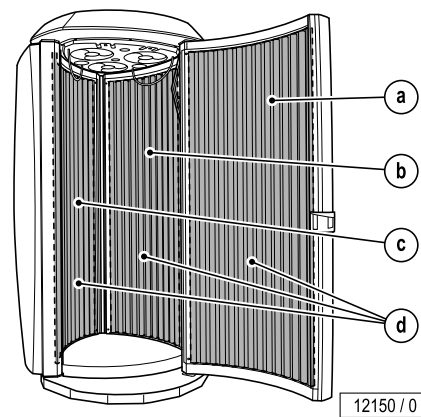

Component	Interval			Activity	See page
	1000 h	1500 h	3000 h		
a Red Light lamps door		X		Replace	37
b Red Light lamps sidewall		X		Replace	39
c Red Light lamps sidewall		X		Replace	39
a, b, c Starter	X			Replace	39
d Acrylic panels			X	Replace	34

5.7 Instructions for replacing the lamps

The lamp effect decreases over the course of time. As such, the replacement intervals specified in the maintenance plan must be adhered to.

5.7.1 Red Light Therapy lamps

- Replace faulty lamps immediately.
- Always replace the entire set of lamps after the specified operating time.
- Turn 90° and carefully remove from the socket.

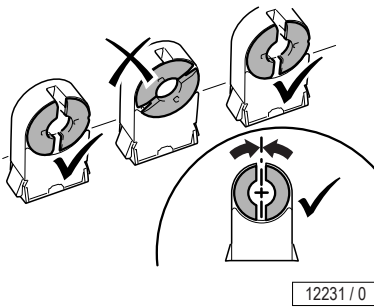
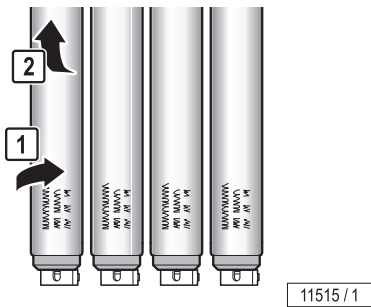

- Push the pins vertically into the socket from above.

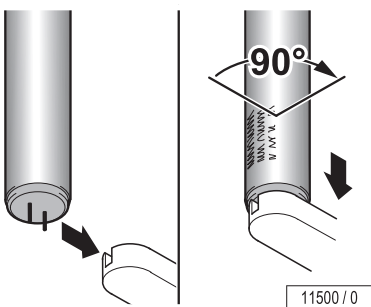

- Turn the lamp 90°.
The lettering must be oriented towards the outside (i.e. towards the user).

5.7.2 Starter

- Replace faulty starters immediately.

You can recognize a faulty starter by the blackened ends of the lamps or when the lamps can no longer be started.

Operating a lamp with a faulty starter significantly shortens its service life. The lamp loses power and may begin to flicker under certain circumstances.

The starters are located in either one of the two lamp sockets or are visible when the lamps are removed.

- Turn 90° and carefully remove from the socket.

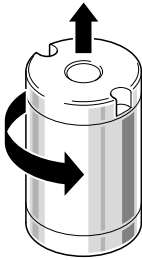

05584 / 0

5.8 Clean or replace lamps in the door

WARNING!



Acrylic panels may be damaged!

Soiling on the panels is burned in by the hot lamps and results in the long term damage to panels.

- Remove fingerprints and other soiling carefully.

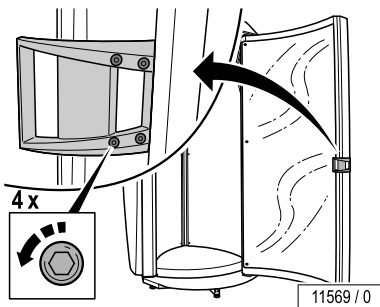

Door handle:

- Remove the screws and remove door handle.

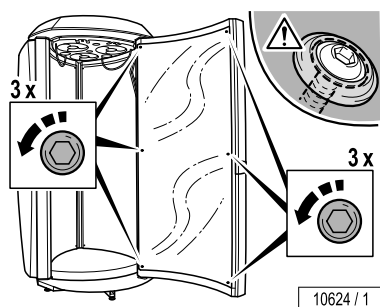

Acrylic glass panel:

- Remove the screws.
- Remove the acrylic panel and carefully lay it aside.

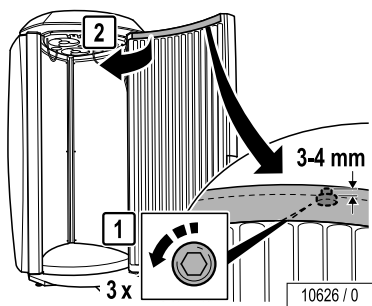

Upper lamp cover:

- Loosen screws 3-4 mm.
- Take off the lamp cover.

Replace the lamps: See page 36.

Replace the starter: See page 37.

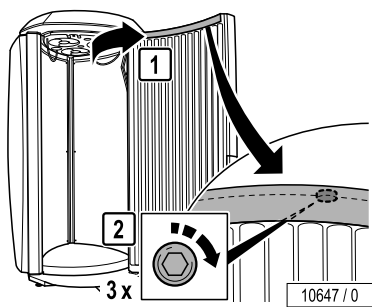

The assembly is the same process in reverse order.

5.9 Clean or replace lamps on the side panels

WARNING!



Acrylic glass panels unusable due to soiling!

Soiling on the panels is burned in by the hot lamps and results in the long term in unserviceable panels.

- Remove fingerprints and other soiling carefully.



NOTE:

There is a risk of damage being caused to the acrylic panels and the cockpit control and the side walls!

Observe the order: First remove the acrylic cover on the **left** and then the one on the **right**.

Do not rub the right acrylic panel against the cockpit control when removing it.

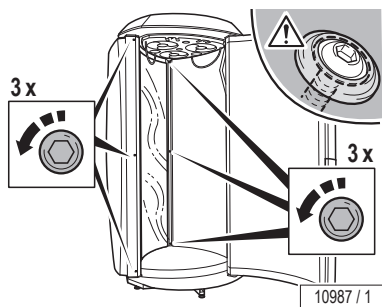

First remove the left acrylic panel:

- Remove the screws.
- Remove the acrylic panel and carefully lay it aside.

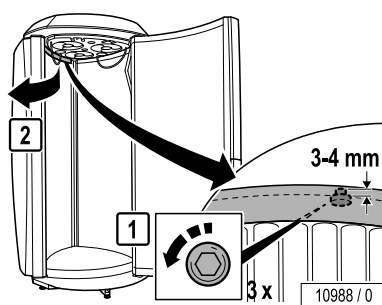

Upper lamp cover:

- Loosen screws 3-4 mm.
- Take off the lamp cover.

Replace the lamps: See page 36.

Replace the starter: See page 37.

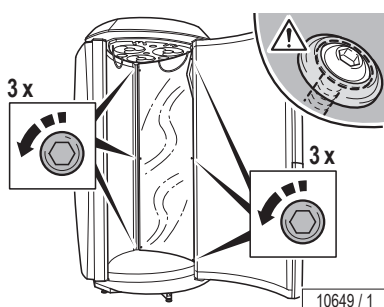

Right acrylic glass panel:

- Remove the screws.

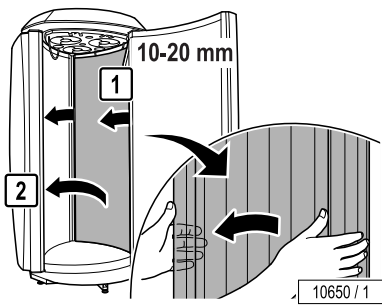

- The panel must be taken out past the cockpit control. Ensure that you do not scratch the panel.

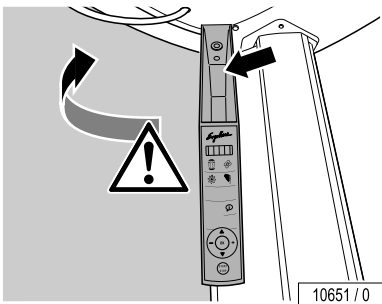

- Carefully pull the panel past the back of the cockpit control and remove to the left.

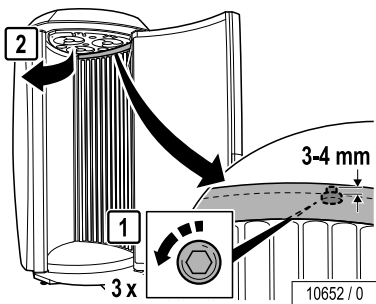

Upper lamp cover:

- Loosen screws 3-4 mm.
- Take off the lamp cover.

Replace the lamps: See page 36.

Replace the starter: See page 37.

The assembly is the same process in reverse order.

When assembling the device please note:

- Always replace the right acrylic panel first.

5.10 Clean or replace Ambient Light

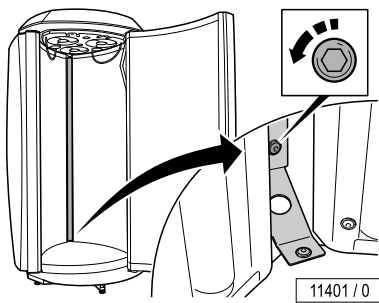

- Remove the screws.

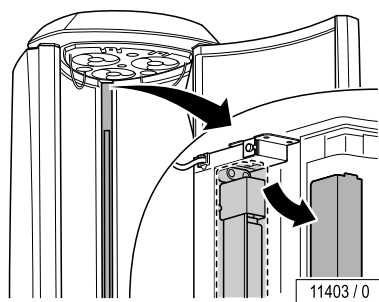

- Remove the lamp cover.

Replace the lamps: See page 36.

Replace the starter: See page 37.

The assembly is the same process in reverse order.

6 Technical data

6.1 Power rating, electrical specifications and noise level

BEAUTY ANGEL	
Nominal power consumption:	8700 W
Rated frequency:	60 Hz
Rated voltage:	230 V
Rated fuses:	30 Amp 3-Pole or 50 Amp 2-Pole
Connecting lead:	
Noise level at 1 m distance from the device:	71,6 dB(A)
Noise level in device:	<81 dB(A)
Load on the base plate:	max. 300 lbs
Weight:	695 lbs

6.2 Dimensions

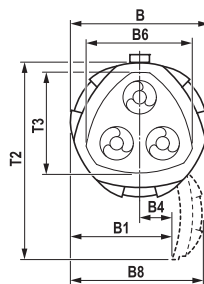
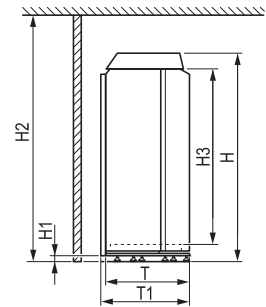
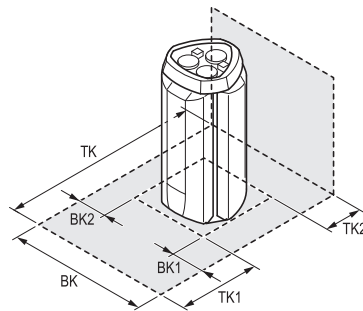

12246 / 0

B =	55 in.
B1 =	35 in.
B4 =	7 in.
B6 =	34 in.
B8 =	54 in.
T =	51 in.
T1 =	55 in.
T2 =	73 in.
T3 =	34 in.
H =	92 in.
H1 =	3 in.
H2 =	102 in.
H3 =	80 in.
BK =	76 in.
BK1 =	20 in.
BK2 =	20 in.
TK =	95 in.
TK1 =	35 in.
TK2 =	12 in.

6.3 Lamp sets

WARNING!



USE ONLY the specified NON-UV Red Light Therapy lamps! The conformity declaration and the ETL Intertek test mark only apply for the specified lamps. The mark is voided if other lamps are used.

Use of UV lamps in this device is a violation of 21 CFR 1040, FDA.

6.3.1 BEAUTY ANGEL

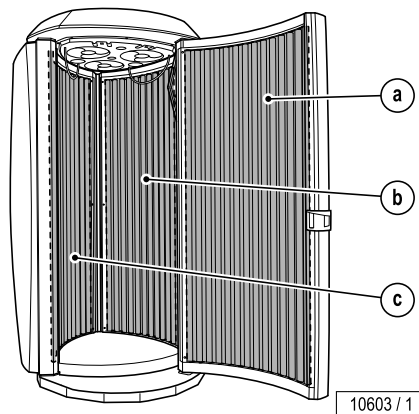

Lamp set

	Number	Description	Length	Order-no.
a)	10	BEAUTY LIGHT FR2000-T12-RED VHO BP180W	1.80 m	1504517-..
	10	Starter Philips BodyTone 120-180W		1503321-..
b)	10	BEAUTY LIGHT FR2000-T12-RED VHO BP180W	1.80 m	1504517-..
	10	Starter Philips BodyTone 120-180W		1503321-..
c)	10	BEAUTY LIGHT FR2000-T12-RED VHO BP180W	1.80 m	1504517-..
	10	Starter Philips BodyTone 120-180W		1503321-..

6.3.2 Accent lighting

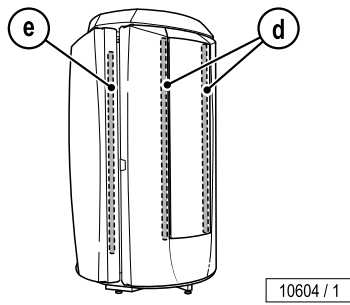

	Number	Description	Power	Order-no.
d)	2	Low pressure lamps blue	58 W	12063-..
	2	Starter S10		10047-..
e)	1	Low pressure lamp blue	58 W	12063-..
	1	Starter S10		10047-..

6.4 Spare parts and accessories

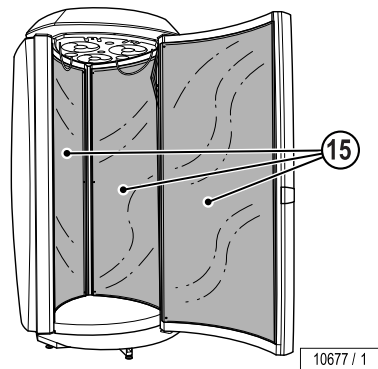

	Number	Description	Order-no.
15	3	Acrylic panels	0041013201

7 Appendix

7.1 Signs and stickers on the device

Signs warning of danger areas are attached to the device. The signs shown below are examples. Ensure that the instruction signs are always clearly recognizable and easily legible.

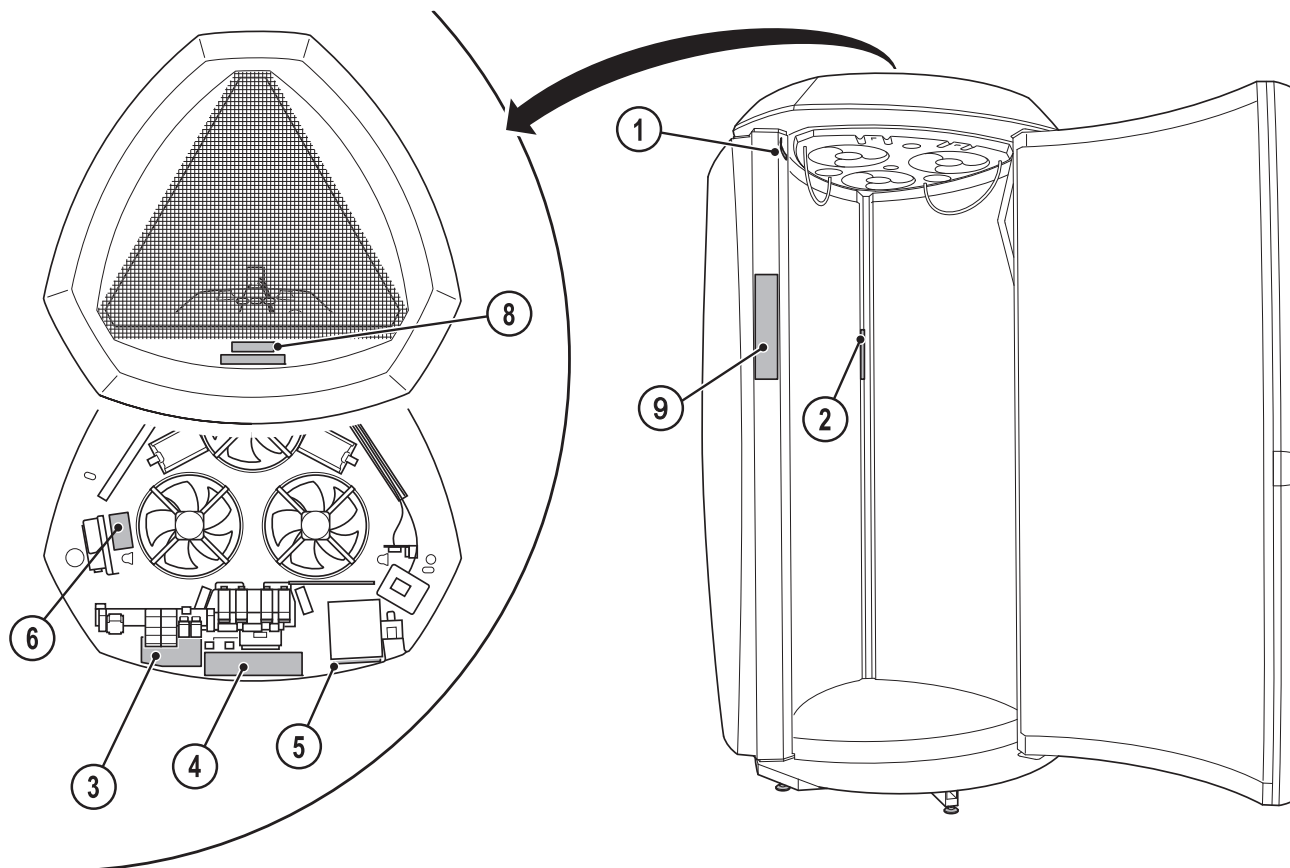

12156 / 1

1: Serial Number

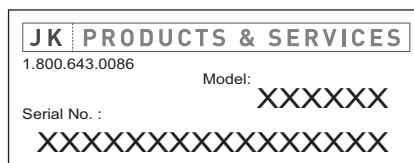

2: Name Plate / ETL Information

JK Products and Services, Inc. #1 Walter Kratz Dr. Jonesboro, AR 72401 1.800.643.0086   ETL RECOGNIZED MEDICAL CLASS 1 ELECTRICAL EQUIPMENT Intertek <small>37925</small> INTERTEK TESTING SERVICES NA INC. CORTLAND, NEW YORK, 13045	MODEL NO. <h1 style="margin: 0;">COL30L</h1> SERIAL NO. <h1 style="margin: 0;">XXXXXXXXXX</h1>
--	---

DATE MANUFACTURED	A/C VOLTS	A/C LAMPS
XXXXXXXXXX	60Hz 230V 1Ø	40A
	60Hz 230V 3Ø	24A

THIS PRODUCT IS IN CONFORMITY WITH PERFORMANCE STANDARDS FOR MEDICAL ELECTRICAL EQUIPMENT UNDER UL 6060 PART 1 AND CSA 601.1
 INTERMITTENT USE: 12 MINUTES ON, 2 MINUTES OFF
CAUTION READ OWNERS MANUAL BEFORE INSTALLING. FOLLOW ALL MANUFACTURER INSTRUCTIONS COMPLETELY AND CAREFULLY. OBSERVE AND FOLLOW ALL CAUTION WARNINGS. INSTALLATION SHOULD ONLY BE COMPLETED BY A QUALIFIED ELECTRICIAN.

The nameplate is located on the edge of the left panel in the space between it and the adjacent panel. It contains important information for identifying the device (e. g. the serial number = Serial-No.).

3: Configuration of electronic components label (1502978-..)

The label is located on the lid below the cover.

4: Controls label (1502983-..)

The label is located on the lid below the cover.

5: ESD (Electrostatic discharge) label - sensitive components (85662-..)

The label is located beneath the PCB.

6: USA mains connection label (1504659-..)

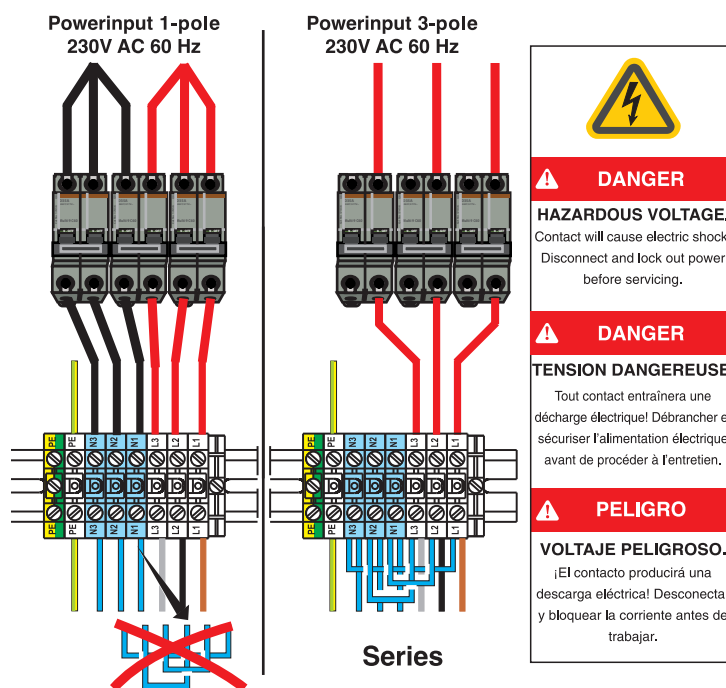

8: 'Not disconnected from power supply' warning label (800698-..)

The label is located on the cover.

9: Exposure Label

Label is located on the outside edge of the left panel.



NOTICE: THIS SYSTEM DOES NOT EMIT ULTRA-VIOLET LIGHT.

This system emits bright light in the 580 – 700 nanometer range. Protective eye wear such as sunglasses or other light reducing eye wear is recommended for people who are sensitive to bright light.

People using medications or cosmetics that may react when exposed to bright light should consult with their physician or pharmacist prior to using this system.

The following people should not use this system:

- Pregnant women
- People with epilepsy
- People under the age of 18
- People with limited / reduced mental capacity
- People with limited / reduced physical or sensory capabilities
- People who are easily disoriented or who experience vertigo

The following people should limit use and consult with a physician prior to use:

- If your skin has been chemically treated in the past 48 hours.
- If your skin has been burned by chemicals, UV-light, fire, etc.
- If you have had any type of invasive surgical procedure in the past 48 hours.

Discontinue use and consult with a physician if you experience:

- Symptoms of vertigo
- Prolonged disorientation
- Seizures
- Vision Impairments lasting for longer than 24 hours

or any other undesirable reactions.

RECOMMENDED USER SCHEDULE
SESSION LENGTH : 12
PROGRAM PERIOD : 90 DAYS
WEEKLY SESSIONS : 2-3
SUBSEQUENT WEEKLY TREATMENTS : 1-2

MAXIMUM SESSION TIME: 12 MINUTES

0051010001

8 Index

- A**
- Accent lighting..... 44
 - Accessories..... 17, 44
 - Acrylic glass (maintenance) 31
 - Acrylic glass panel (product information) 33
 - Adolescents 19
 - Treatment
 - Description 18
 - Assembly 9
- B**
- Base plate
 - Permitted load 41
- C**
- Clean or replace Ambient Light. 40
 - Clean or replace lamps
 - door 36
 - side walls 38
 - Cleaning 30
 - Lamps 31
 - Cleaning intervals 32
 - Cleaning overview 32
 - Commissioning 11
 - Connect MP3 player 28
 - Copy protection 13
 - Cosmetics 19
 - Customer service 2
- D**
- Decommissioning..... 12
 - Definitions 5
 - Description 16
 - Device description..... 16
 - Device operating time 11
 - Dimensions 42
 - Disinfection 30
- E**
- Electrical installation 10
 - Electrical specifications 41
- F**
- Equipment..... 15
 - Exhaust air ventilation 10
 - Export..... 12
 - Eye damage 19
- F**
- Fault codes 30
 - Faults 30
 - Foreseeable misuse..... 8
 - Functions 26
- G**
- Guarantee 14
- I**
- Instruction signs 13
 - Intended use 8
 - Itching 19
- L**
- Lamp sets 43
 - Lamps
 - Control..... 43
 - Power level..... 43
 - Rated power 43
 - Light sensitivity..... 19
- M**
- Maintenance 29, 30, 33
 - Maintenance Cleaning 29
 - Maintenance overview 34
 - Measurements 42
 - Medications 19
 - MP3 music 13
 - Musculature 18
- N**
- Noise level 41
- O**
- Operating altitude..... 11
 - Operating overview 24
 - Operator's obligations 9

Order numbers 43, 44

P

Personnel training 9

Plastic surfaces (maintenance) 31

Play rights 13

Plug-in connector 10

Power output 41

Product information 8

Protective glasses 19

Protective measures when
performing maintenance work ..29

R

Replacing lamps 35

Replacing the lamps..... 35

Replacing the starter 36

Risk of injury..... 19

S

Safety 10

Safety equipment 14

Scope of delivery..... 9, 15

Setup..... 9

Setup location 11

Sickness..... 19

Side effects VibraShape..... 20, 21

Spare parts..... 34

Order numbers 44

Start application 27

Starter 43

Start-up settings 27

Storage..... 12

Symbols 7

T

Technical data 41

Time control 11

Transport..... 9

Treatment..... 18

Treatment programmes..... 17

V

Ventilation 10

VibraShape

Description..... 18

Vibration plate 18

W

Warranty..... 14

Whole Body Vibration..... 18

WARNING!

This device is designed for use with NON-UV emitting lamps only!

Use of UV lamps, or any lamps other than those specified for use in this device, may cause serious injury and is considered a violation of FDA regulations including:

Code of Federal Regulations Title 21 CFR1040
 TITLE 21--FOOD AND DRUGS
 CHAPTER I--FOOD AND DRUG ADMINISTRATION
 DEPARTMENT OF HEALTH AND HUMAN SERVICES
 SUBCHAPTER J--RADIOLOGICAL HEALTH PART 1040
 PERFORMANCE STANDARDS FOR LIGHT-EMITTING PRODUCTS

Violation of this code may subject the violator(s) to litigation, fines, and possible imprisonment, etc.

Furthermore, adulterating this device in any way (including relabeling or using UV lamps etc) will void the ETL listing of the device. Such action will cause the device to be considered out of compliance with federal, state, and local regulations.

If you have any questions regarding lamp replacement procedures, proper use, etc please contact the manufacturer directly at 1-800-643-0086.



BEAUTY ANGEL

~~JK-DFC81 7HG5B8 09FJ 79GZ B7'~~

1 Walter Kratz Drive
 Jonesboro, AR 72401
 Phone: 800.643.0086 (Toll-free)
 Fax: 870.395.3618
 Internet: www.beautyangel.us
 E-Mail: ergoline@sunergoline.com